

R22-series Horizontal Stabilizer Retrofit Kit Instructions

Kit replaces A044-1 horizontal stabilizer with B902-2 vertical stabilizers mount assembly, and installs B375-2 horizontal (symmetrical) stabilizer assembly. Kit is eligible for installation on all R22 models except R22 Mariner. Additionally, helicopter must be equipped with A958-1 bellcrank, originally installed on S/N 0256, 0301, 0350, 0351, and 0357 & subsequent. Helicopter serial numbers not in this range must upgrade bellcrank per R22 Maintenance Manual § 8.111. To determine eligibility for installation, refer to R22 Service Letter SL-98 (current-revision).

NOTE

Visit <https://robinsonheli.com/> to verify kit instructions are current revision. Review instructions before installation; contact RHC Technical Support with questions. Verify kit contents match list; contact RHC Customer Service if parts are missing or damaged.

ITEM	PART NUMBER	KIT CONTENTS	QTY
1	KI-285-3Instr.	Kit Instructions	1
2	A654-3	Decal – “DANGER”	2
3	B204-5	Blind Rivet (includes 2 extra)	10
4	B330-13	Palnut	2
5	B375-2.CS*	Horizontal Stabilizer Assembly	1
6	B379-2**	Doubler (This part will be provided unless alternate part [below] is selected.)	2
	B379-2.CS*	Doubler	0
7	B379-3**	Bracket (Field; This part will be provided unless alternate part [below] is selected.)	1
	B379-3.CS*	Bracket (Field)	0
8	B900-17	Component Modifications Plate	1
9	B902-2.CS*	Vertical Stabilizers Mount Assembly	1
10	D210-3	Nut	2
11	D210-4	Nut	2
12	MT858	Locator Tool – Horizontal Stabilizer. Includes: [1] MT858-1 Bracket [1] MT858-2 Cover [1] MT858-3 Plate [1] MT858-4 Template	1
13	MS21069L3	Nutplate	4
14	MS3367-4-9+	Ty-rap (Note: “+” in part number indicates 20-qty pack)	1
15	MS3367-5-9+	Ty-rap (Note: “+” in part number indicates 20-qty pack)	1
16	NAS1149F0332P+	Washer (Note: “+” in part number indicates 20-qty pack)	1
17	NAS1149F0432P+	Washer (Note: “+” in part number indicates 20-qty pack)	1
18	NAS1149F0463P+	Washer (Note: “+” in part number indicates 20-qty pack)	1
19	NAS6603-2	Bolt	6

ITEM	PART NUMBER	KIT CONTENTS (continued)	QTY
20	NAS6604-28	Bolt	2
21	NAS9301B-5-02	Blind Rivet (includes 3 extra)	15
22	NAS9301B-5-03	Blind Rivet (includes 1 extra)	5

* “.CS” suffix indicates indicates part has paint finish options; contact Customer Support.
 ** Finish is primer only.

Consumables

Refer to R22 Maintenance Manual (MM) § 23-70 for approved materials list.

- B270-1 Sealant

Special Tools

- Precision hand drill (less than 0.001 inch runout measured 1 inch from chuck)
- Deburring tool
- 10-32 thread nutplate jig
- Step drill or hole saw
- 12-inch (minimum) straight edge
- Precision bubble or digital protractor, having 0.1 degree resolution
- Rivet puller, suitable for structural #5 blind rivets
- #30 hole finder

Kit Instructions

1. Ensure ignition switch is OFF; remove key. Turn BATTERY switch OFF.
2. Remove A044-1 horizontal stabilizer assembly, including A301 ballast weights (if installed) per MM § 4.540. Remove and retain tail light per MM § 24-12. Discard palnuts & nuts and retain remaining hardware. Remove tail skid per MM § 4.600. Remove DANGER decal from both sides of tailcone.
3. Visually inspect four rubber mounts on main rotor gearbox and verify no contamination or damage; replace as required. Level helicopter per MM § 18-10.

CAUTION

Prior to drilling, inspect opposite side for obstruction(s). As required, relocate and/or remove obstruction(s).

4. Refer to Figure 1. Locate 3rd and 6th longitudinal rivets, counting from first rivet as shown. Drill out noted rivets using #30 drill fitted with drill stop.
5. Refer to Figures 2 and 3. Place MT858-1 bracket on tailcone, with “FWD” marking as indicated. Secure with clecos at newly drilled-out rivet locations. Attach MT858-2 cover to bracket using clecos. Place protractor laterally across forward posts of bracket as shown and verify locator tool is level (use straight edge atop posts if protractor cannot contact both posts). As required, rotate locator tool on tailcone by lightly tapping with a rubber or plastic mallet (bottom holes are slotted), until protractor indicates level/zero. Repeat procedure with protractor placed laterally across aft posts.

Kit Instructions (continued)

NOTE

Once protractor/level indicates zero with first reading, subsequent readings are allowed a tolerance of ± 0.5 degree.

6. Using #30 drill fitted with drill stop, drill thru skin at LH forward hole in bracket and install cleco. Verify locator tool remains level. Drill #30 pilot hole thru skin at RH forward hole in bracket and install cleco. Verify locator tool remains level. Drill #30 pilot hole thru skin at LH aft hole in bracket and install cleco. Drill #30 pilot hole thru skin at RH aft hole in bracket. Remove clecos and locator tool.
7. Refer to Figure 4. Enlarge (4) newly-drilled pilot holes to 0.195–0.201 inch diameter using #8 drill fitted with drill stop. Layout dimensions to locate center of (2) 0.75 inch diameter holes, one each LH & RH side of tailcone, as shown. Drill (2) #30 pilot holes using drill fitted with drill stop at marked (center) location. Using a step drill or hole saw, enlarge (2) newly-drilled pilot holes to 0.750 inch diameter. Deburr holes. At installer's discretion, alodine and/or prime/paint hole edges as described in NOTE below.

NOTE

After trimming or filing aluminum, finish edges as follows: Deburr trimmed edges with 220-grit or finer wet-or-dry aluminum oxide abrasive paper. Solvent-clean deburred edge and apply Bonderite M-CR 1132, or Bonderite M-CR 1201 Aero in accordance with manufacturer's instructions. Apply epoxy primer to dry edge. Touch up with helicopter paint color, where applicable, is optional.

8. Refer to Figures 4 & 5. Using appropriate 10-32 thread nutplate drill jig, match drill (8) 0.097–0.102 inch diameter nutplate installation rivet holes in A023-12 skin. Create 0.135–0.155 inch diameter, 100° countersinks at rivet installation holes. Install (4) MS21069L3 nutplates using (8) B204-5 rivets on A023-12 skin.
9. Refer to Figure 5. Temporarily attach (2) B379-2 doublers to tailcone using (4) NAS6603-2 bolts. Using doublers as templates, progressively match drill (6) 0.158–0.164 inch diameter holes and install clecos thru A023-12 skin. Make a non-permanent mark on doubler to indicate doublers' position relative to tailcone; also mark doubler to indicate left or right side of helicopter. Remove doublers, deburr holes and clean up debris. Strobe light may be removed to access inside tailcone (ref. MM § 24-11). At installer's discretion, alodine and/or prime/paint hole edges as described in NOTE in step 7.
10. Refer to Figure 6. Install doublers to tailcone skin using (12) NAS9301B-5-02 rivets, removing clecos one at a time as required. Inspect installed rivets per manufacturers' specifications at: [CA-1015.pdf \(cherryaerospace.com\)](http://cherryaerospace.com).
11. Refer to Figures 7 & 8. Using hardware provided in kit, install one MT858-3 plate to each side of tailcone and attach B379-3 bracket (apex forward as shown in Figure 8) to plates.

Kit Instructions (continued)

12. Using hole finder and #30 drill fitted with drill stop, locate holes in tailcone and progressively match drill & cleco (2) holes thru B379-3 bracket. Enlarge holes in bracket & tailcone to 0.158-0.164 inch diameter using #21 drill fitted with drill stop. Temporarily attach MT858-4 template to bracket & tailcone using clecos. Drill (2) 0.158–0.164 inch diameter holes in tailcone skin thru template, bracket & tailcone. Remove template and B379-3 bracket. Deburr holes & clean up debris. At installer's discretion, chemically treat and/or prime/paint hole edges as described in NOTE in step 7.
13. Apply B270-1 sealant around B379-2 doubler as shown in Figure 6. Apply a small bead of B270-1 sealant around the two rivet holes in B379-3 bracket (two places), as shown in Figure 9.
14. Install B379-3 bracket (with apex forward) using four clecos. Replace clecos, one at a time, with NAS9301B-5-03 rivets. Inspect installed rivets per manufacturers' specifications at: <CA-1015.pdf> (cherryaerospace.com)
15. Refer to Illustrated Parts Catalog (IPC) Figure 53-29. While supporting B375-2 horizontal stabilizer assembly, secure stabilizer to tailcone using (4) NAS6603-2 bolts and (4) NAS1149F0332P washers. Secure stabilizer to B379-3 bracket using (2) NAS6603-2 bolts, (4) NAS1149F0332P washers, and (2) D210-3 nuts. Special torque hardware per MM § 23-33, and torque stripe per MM Figure 2-1.
16. Install strobe light per MM § 24-11, if removed.
17. Refer to IPC Figure 53-25. Install B902-2 vertical stabilizers mount assembly per MM § 4.530 using (2) NAS6604-28 bolts, NAS1149F0432P under head, NAS1149F0463P under nut, D210-4 nuts & (2) B330-13 palnuts. Install tail light per MM § 24-12.
18. Install A042-1 upper vertical stabilizer per MM § 4.510.
19. Install A043-1 lower vertical stabilizer per MM § 4.520.
20. Install tail skid per MM § 4.600.
21. Refer to Figure 10. Install A654-3 decal to both sides of tailcone in location shown, per MM § 21-10.
22. Install B900-17 component modification plate adjacent to existing A023-XX (tailcone) identification plate.
23. Touch-up paint, as required. Paint codes are located in the Aircraft Logbook.
24. Weigh helicopter per MM § 18-20, installing ballast as required. Revise helicopter's Weight and Balance Record in Pilot's Operating Handbook (POH) Section 6.

NOTE

Remove nose ballast before adding empennage ballast.

NOTE

Component Record (RF 294), required for B375-2 horizontal stabilizer assembly, is printable from our website. Go to: <https://robinsonheli.com/CustomSupport/MaintenanceRecord>. Refer to MM § 3.300 Airworthiness Limitations for horizontal stabilizer life limit.

25. Make appropriate maintenance record entries.

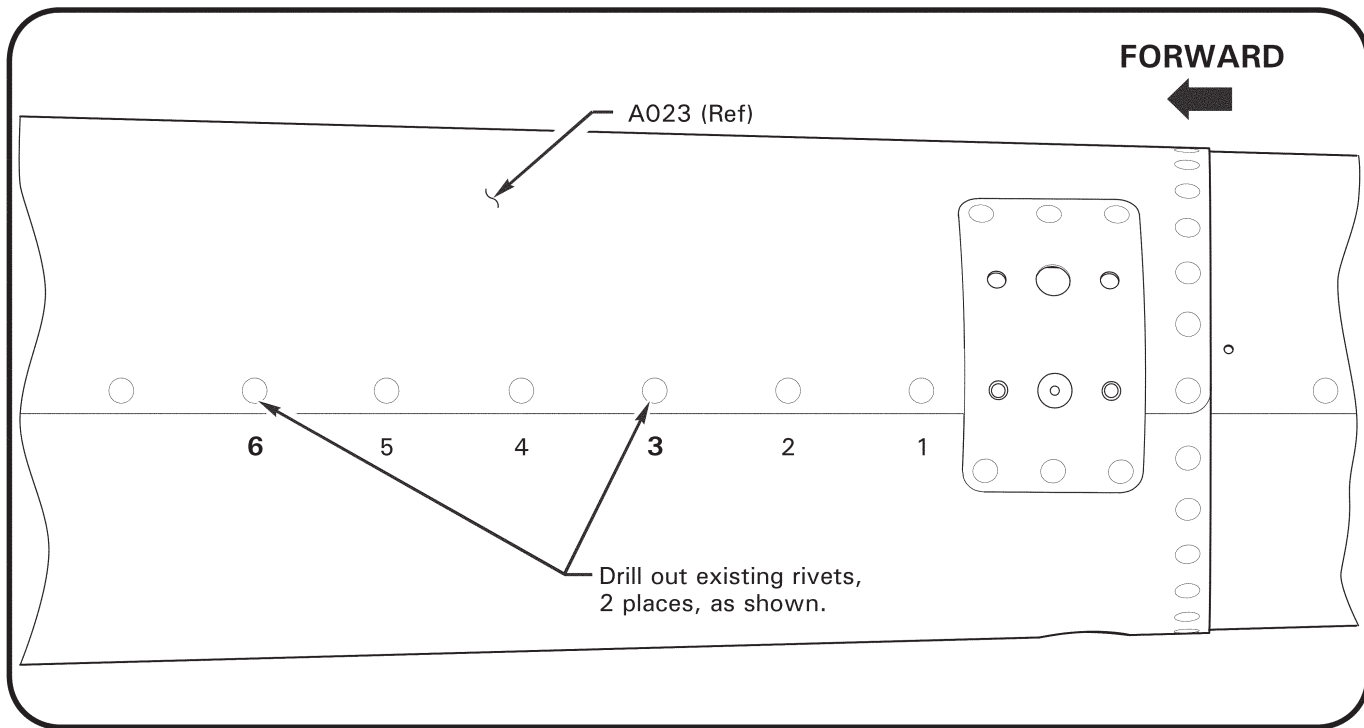

FIGURE 1 Locate & remove tailcone rivets
(tailcone bottom, view looking up)

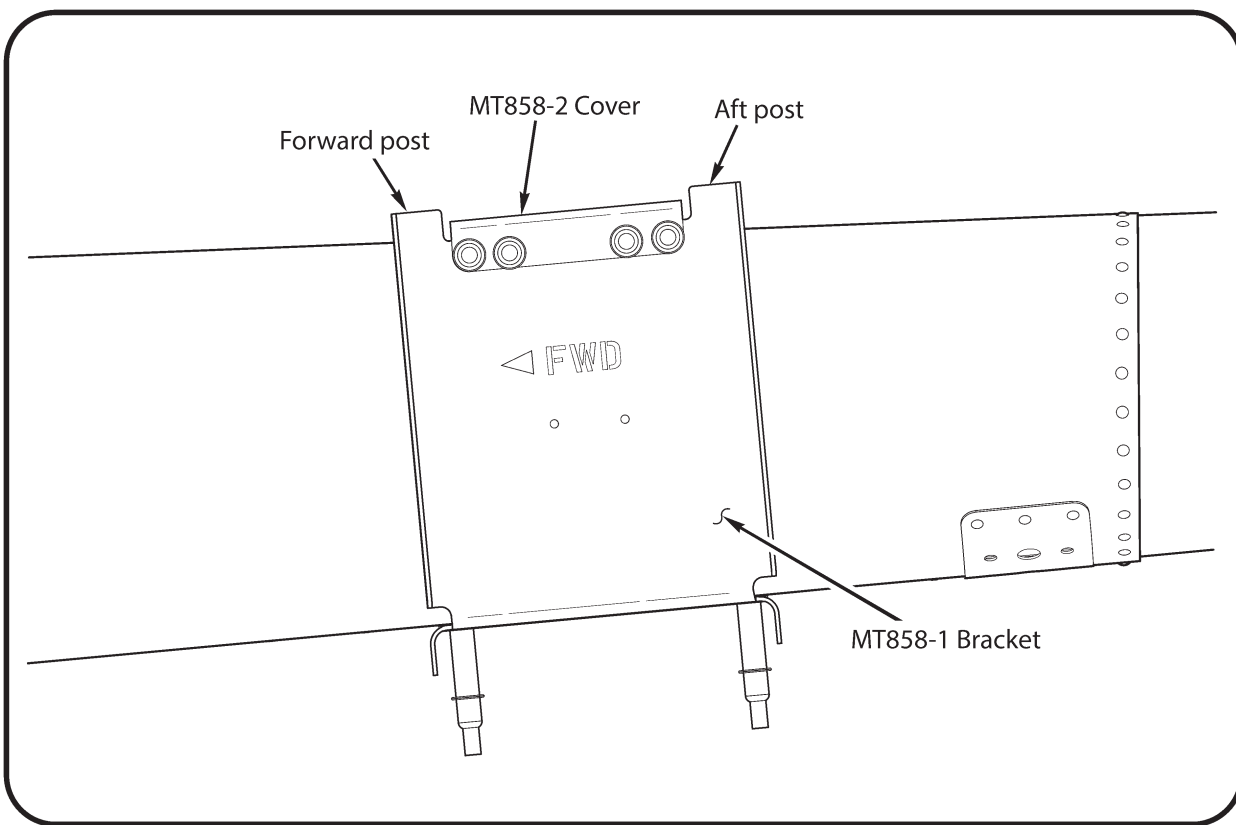

FIGURE 2 Positioning MT858 Locator tool
(verify tool is laterally level)

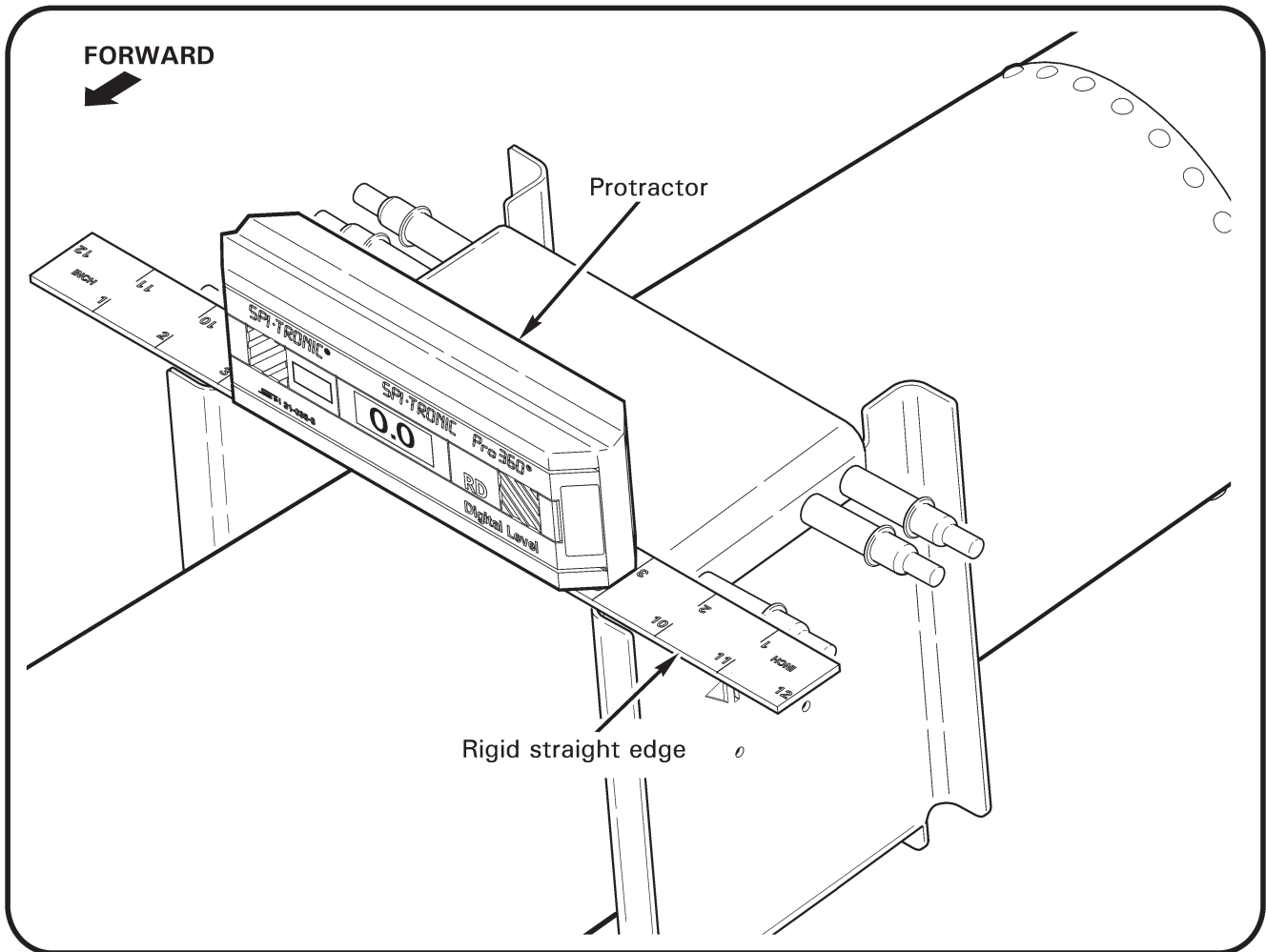

FIGURE 3 Positioning MT858 Locator tool
(verify tool is laterally level)

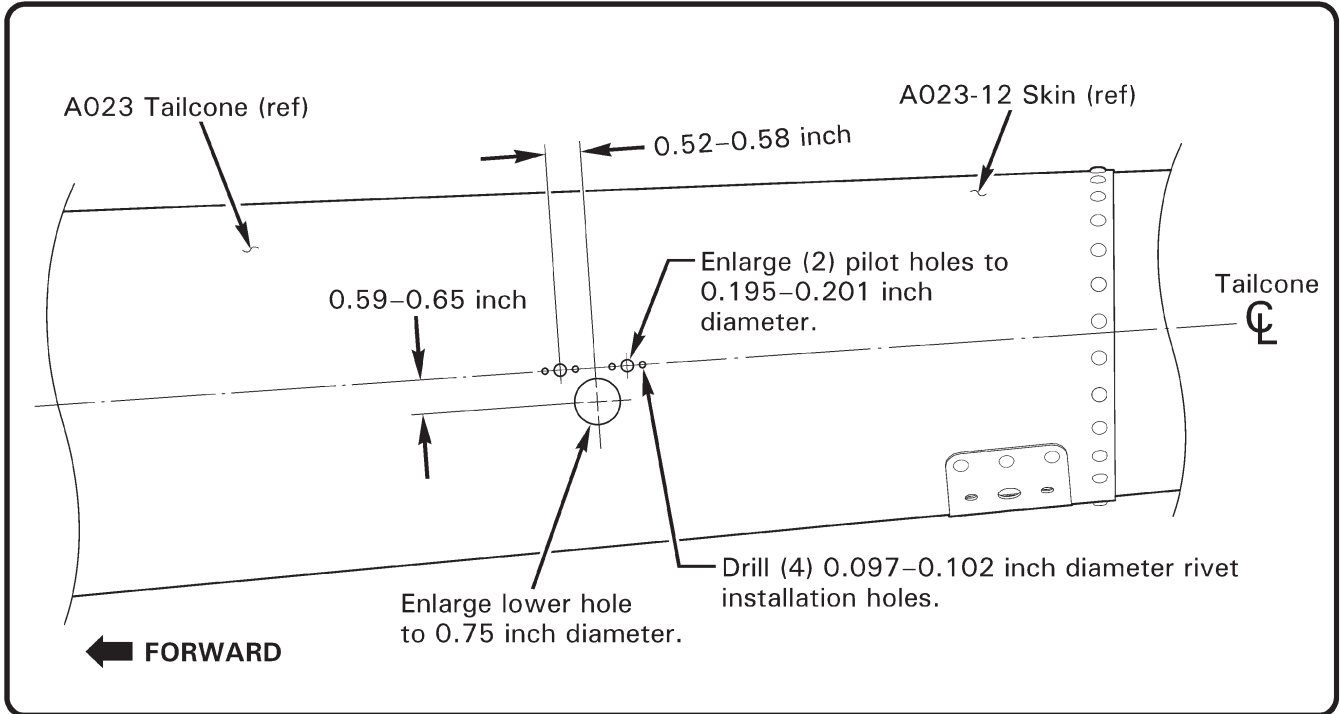

FIGURE 4 Holes for nutplate installation
(LH side shown, RH side similar)

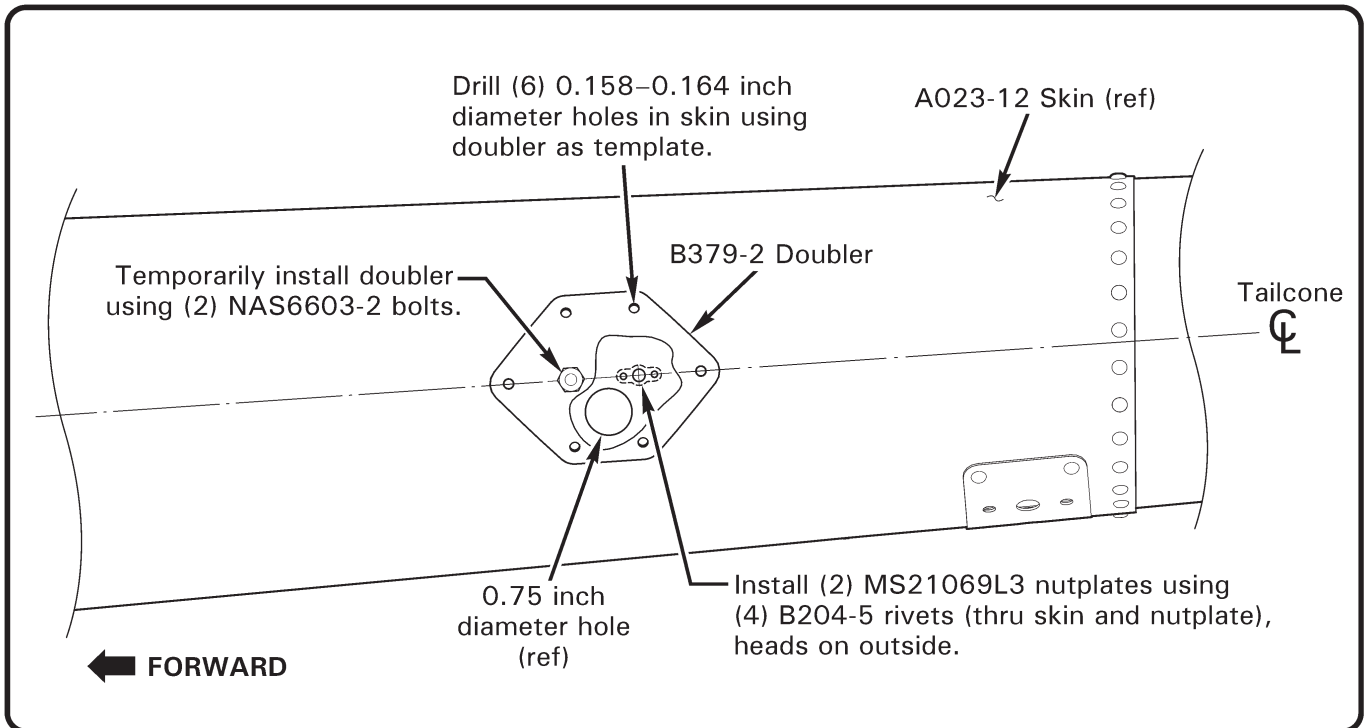

FIGURE 5 Positioning doubler for drilling
(LH side shown, RH side similar)

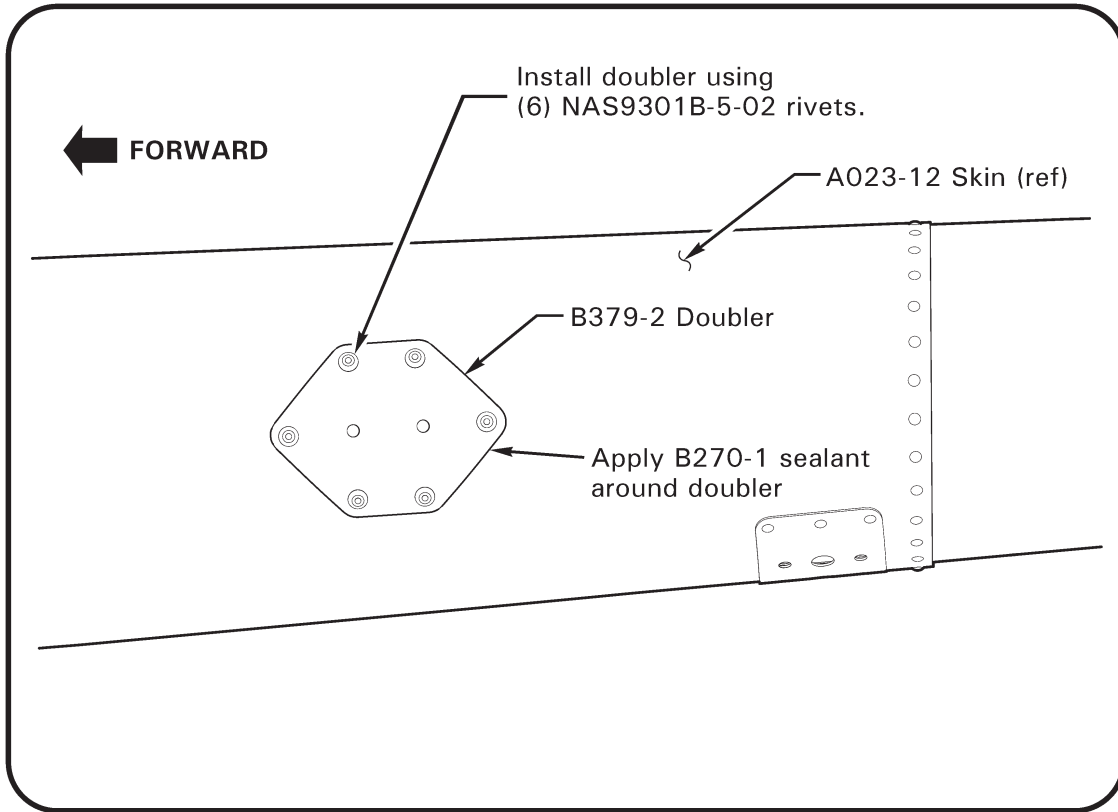

FIGURE 6 Doubler installation
(LH side shown, RH side similar)

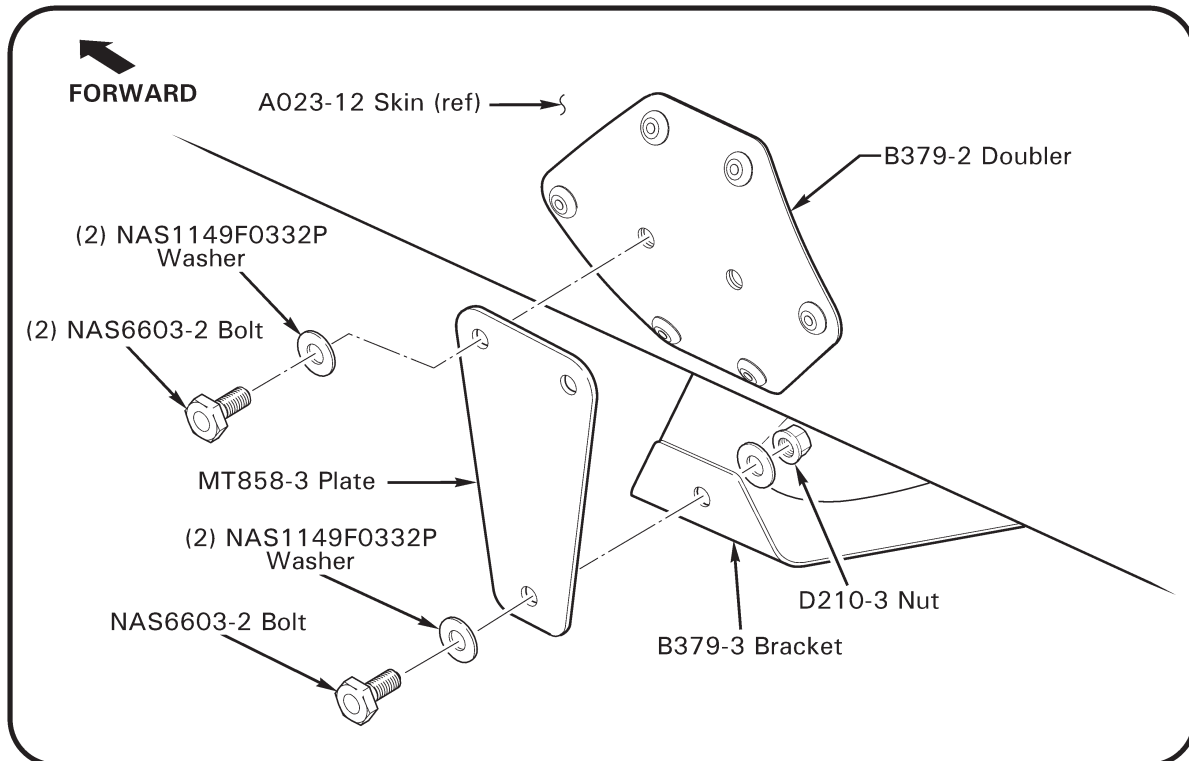

FIGURE 7 MT858-3 plate & B379-3 bracket installation
(LH side shown, RH side similar)

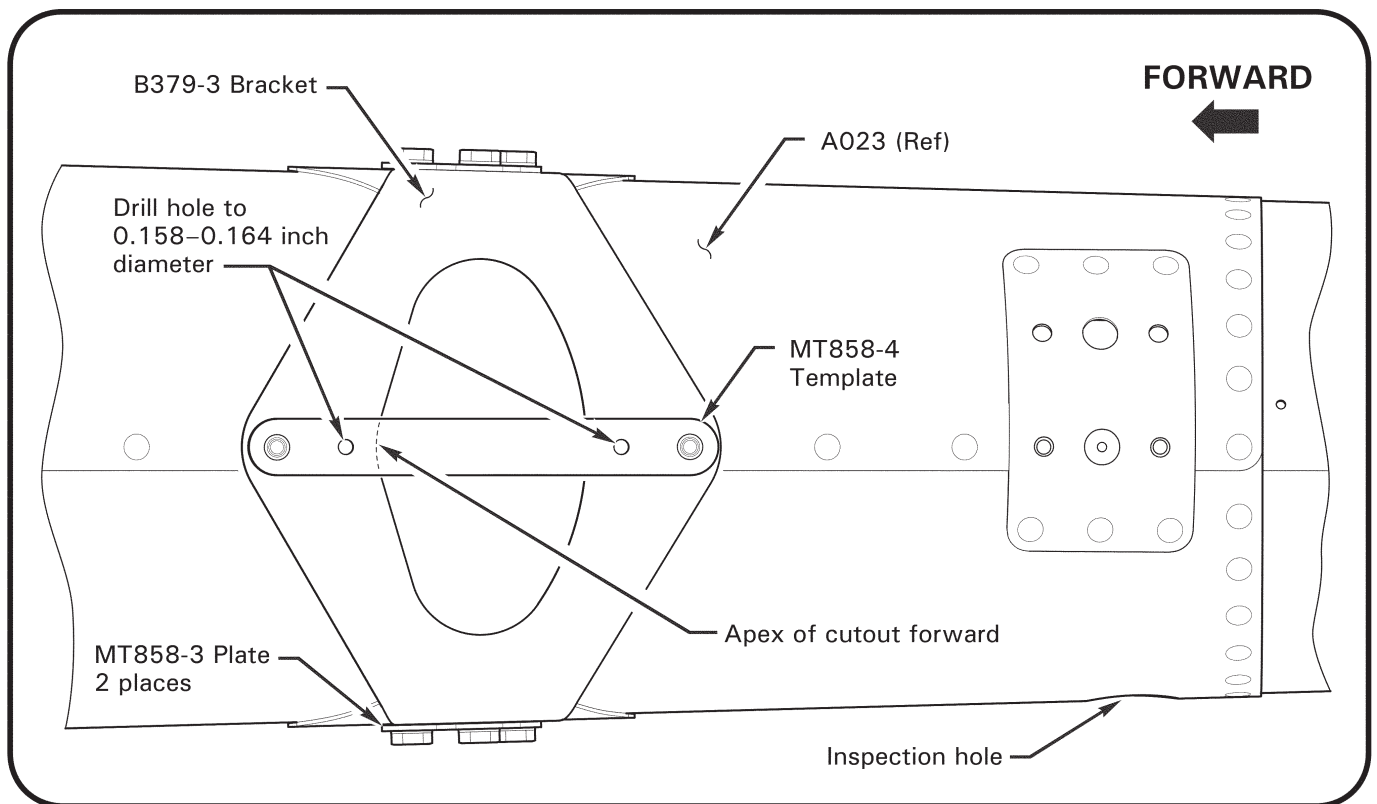

FIGURE 8 Drilling of B379-3 bracket
(view looking up)

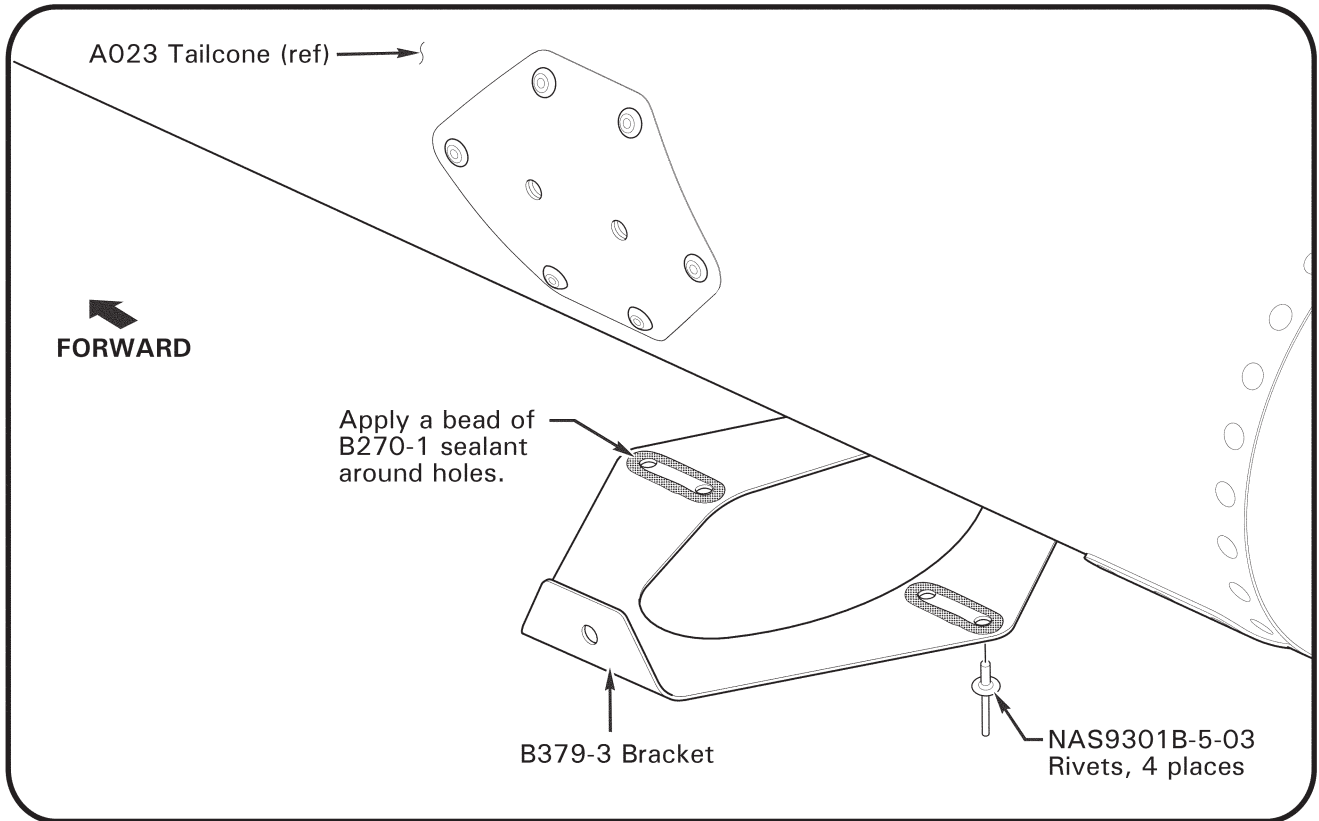

FIGURE 9 B379-3 bracket installation
(application of B270-1 sealant)

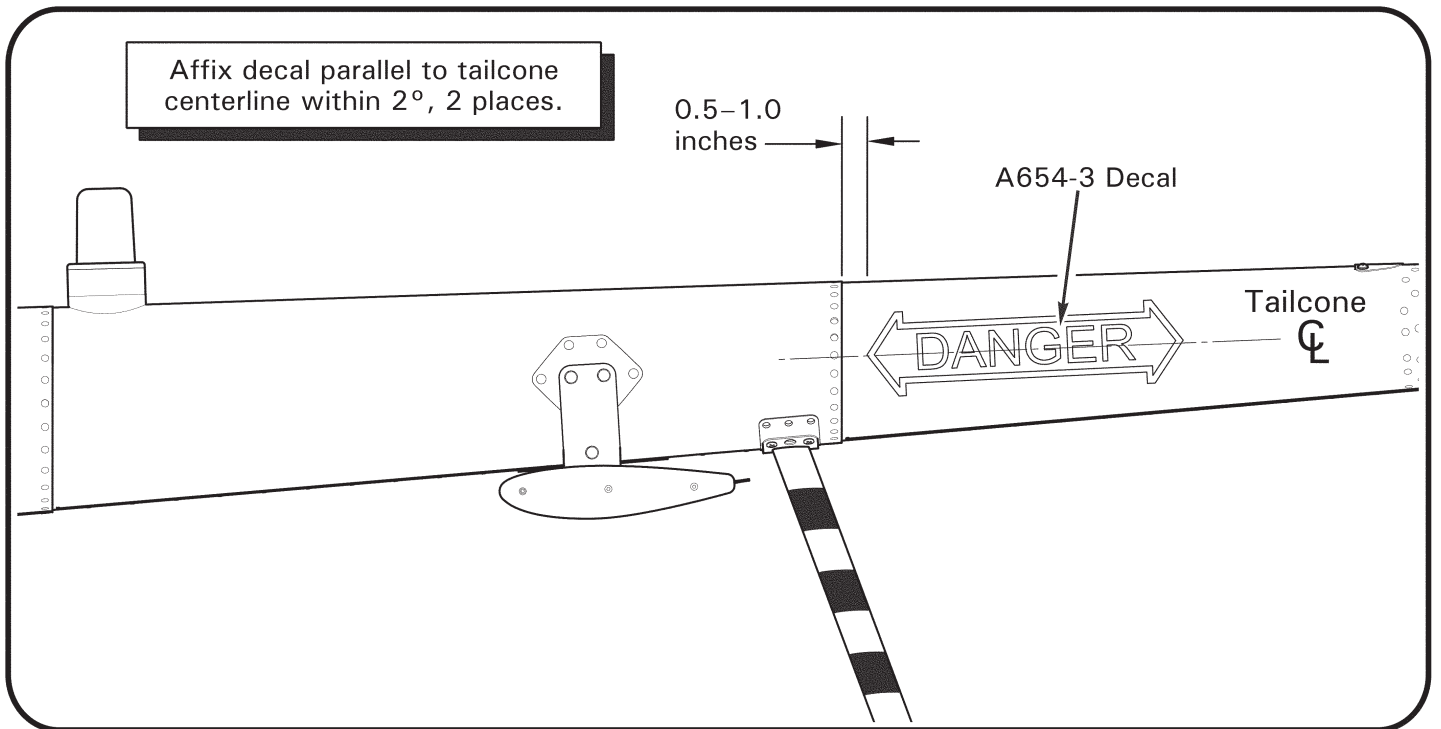

FIGURE 10 A654-3 decal installation
(LH side shown, RH side similar)