

**SECTION 7  
SYSTEMS DESCRIPTION  
CONTENTS**

	<b>Page</b>
General . . . . .	7-1
Rotor Systems . . . . .	7-2
Drive System . . . . .	7-2
Powerplant . . . . .	7-3
Flight Controls . . . . .	7-3
Removable Flight Controls . . . . .	7-5
Control Friction Adjustment . . . . .	7-6
RPM Governor . . . . .	7-6
Hydraulic System . . . . .	7-7
Engine Controls . . . . .	7-8
Clutch Actuator . . . . .	7-9
Fuel System . . . . .	7-10
Electrical System . . . . .	7-12
Lighting System . . . . .	7-17
External Power Receptacle (Optional) . . . . .	7-18
Instrument Panel . . . . .	7-18
Audio System . . . . .	7-23
Optional Avionics . . . . .	7-23
Pitot-Static System . . . . .	7-24
Dual Tachometer . . . . .	7-24
Warning and Caution Lights . . . . .	7-25
Audio Alerts . . . . .	7-26
Engine Monitoring Unit . . . . .	7-27
Cabin Heating and Ventilation . . . . .	7-28
Seats, Belts, and Baggage . . . . .	7-28
Landing Gear . . . . .	7-29
Rotor Brake . . . . .	7-30
Carbon Monoxide Detector . . . . .	7-31
ADS-B Equipment . . . . .	7-32
Emergency Locator Transmitter (Optional) . . . . .	7-33
Accessory Mounts (Optional) . . . . .	7-34
Cockpit Camera (Optional) . . . . .	7-35
Cyclic Guard (Optional) . . . . .	7-36

INTENTIONALLY BLANK

## **SECTION 7**

### **SYSTEMS DESCRIPTION**

#### **GENERAL**

The R44 II is a four-place, single main rotor, single engine helicopter constructed primarily of metal and equipped with skid-type landing gear.

The primary fuselage structure is welded steel tubing and riveted aluminum sheet. The tailcone is a monocoque structure in which aluminum skins carry most primary loads. Fiberglass and thermoplastics are used in secondary cabin structure, engine cooling shrouds, and various other ducts and fairings. The cabin doors are also constructed of fiberglass and thermoplastics.

Four right-side cowl doors provide access to the main gearbox, drive system, and engine. A left-side engine cowl door provides access to the engine oil filler and dip stick. Additional access to controls and other components for maintenance is provided by removable panels and cowlings.

Stainless steel firewalls are located forward of and above the engine.

The four cabin doors are removable. Refer to Section 8 for removal and installation procedures.

## **ROTOR SYSTEMS**

The main rotor has two all-metal blades mounted to the hub by coning hinges. The hub is mounted to the shaft by a teeter hinge. The coning and teeter hinges use self-lubricated bearings. Droop stops for the main rotor blades provide a teeter hinge friction restraint which normally prevents the rotor from teetering while starting or stopping. Pitch change bearings for each blade are enclosed in a housing at the blade root. The housing is filled with oil and sealed with an elastomeric boot. Each blade has a thick stainless steel spar at the leading edge which is resistant to corrosion and erosion. The skins are bonded to the spar approximately one inch aft of the leading edge. Blades must be refinished if the paint erodes to bare metal at the skin-to-spar bond line. Bond may be damaged if bond line is exposed.

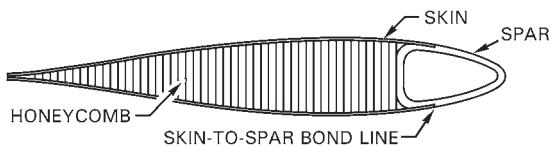

**MAIN ROTOR BLADE CONSTRUCTION**

The tail rotor has two all-metal blades and a teetering hub with a fixed coning angle. The pitch change bearings have self-lubricated liners. The teeter hinge bearings are elastomeric. The tail rotor blades are constructed with aluminum skins and root fittings. Maintaining the paint finish will reduce corrosion and erosion.

## **DRIVE SYSTEM**

A vee-belt sheave is bolted directly to the engine output shaft. Vee-belts transmit power to the upper sheave which has an overrunning clutch contained in its hub. The inner shaft of the clutch transmits power forward to the main rotor and aft to the tail rotor. Flexible couplings are located at the main gearbox input and at each end of the long tail rotor drive shaft.

The main gearbox contains a single-stage spiral-bevel gear set which is splash lubricated. Cooling ducts under the gearbox are connected to the top of the engine cooling scroll. The main gearbox is supported by four rubber mounts.

### **DRIVE SYSTEM (cont'd)**

The long tail rotor drive shaft has no support bearings but has a lightly-loaded damper bearing. The tail gearbox contains a single 90° splash-lubricated spiral-bevel gear set.

### **POWERPLANT**

One Lycoming IO-540 six-cylinder, horizontally-opposed, overhead-valve, air-cooled, fuel-injected engine with a wet sump oil system powers the helicopter. The engine is equipped with a starter, alternator, shielded ignition, two magnetos, muffler, two oil coolers, oil filter, and induction air filter. See Sections 1 and 2 for powerplant specifications and limitations.

A direct-drive, squirrel-cage fan wheel mounted to the engine output shaft supplies cooling air to the cylinders and oil coolers via a fiberglass and aluminum shroud.

Induction air enters through an opening on the right side of the fuselage and passes through the air filter within the air box. Air then passes along a flexible duct, through the fuel control, and into the engine. A spring-loaded door in the air box automatically opens to bypass the filter with engine compartment air should the filter or intake become blocked.

The pilot should adhere to recommended procedures in the Lycoming Operator's Manual to obtain maximum engine life and efficiency.

### **FLIGHT CONTROLS**

Dual controls are standard equipment and all primary controls are actuated through push-pull tubes and bellcranks. Bearings used throughout the control system are either sealed ball bearings which do not require lubrication or have self-lubricated liners.

**FLIGHT CONTROLS (cont'd)**

Flight control operation is conventional. The cyclic is center mounted with the left and right control grips mounted to a cross tube which pivots on the center cyclic post. On later aircraft, the pilot's cyclic grip angle can be adjusted fore and aft relative to the cross tube by a mechanic to achieve the most comfortable hand position. The most forward position provides the most control clearance at aft cyclic for larger pilots. Pilots should always verify the ability to apply full control travel prior to flight.

Collective operation is conventional. The engine throttle is correlated to collective inputs through a mechanical linkage. When the collective is raised, the throttle is opened and when the collective is lowered, the throttle is closed. The collective stick also incorporates a twist grip throttle control which is described in the Engine Controls section.

***CAUTION***

Above 6000 feet (1800 meters), throttle-collective correlation and governor are less effective. Therefore, power changes should be slow and smooth.

***CAUTION***

At high power settings above 6000 feet (1800 meters), the throttle is frequently wide open and RPM must be controlled with collective.

Right-side tail rotor pedals are adjustable. To adjust, remove quick-release pin on each pedal by depressing button and pulling. Slide pedal fore or aft to most comfortable of three adjustment positions and reinstall quick-release pin. Verify pins are secure before flight.

Left-side pedals are not adjustable. However, optional pedals designed for shorter pilots (Robinson part nos. F755-9 and -10) may be installed in place of standard pedals.

## **REMOVABLE FLIGHT CONTROLS**

Left seat pilot controls may be removed and installed by maintenance personnel or pilots as follows:

1. To remove cyclic grip, remove quick-release pin by depressing button and pulling, then pull outward on left grip while supporting cyclic center post. Rotate right-side cyclic cross tube clockwise to stop, depress stop pin under cyclic pivot, and continue clockwise rotation one turn to wind up balance spring. To install removable cyclic grip, use reverse procedure.

### ***NOTE***

Later aircraft have a knurled ring next to the quick-release pin which may be hand tightened to eliminate freeplay. The ring must be loose (rotate counterclockwise looking inboard) to remove pin.

### ***CAUTION***

Overrotating cyclic cross tube in either wound or unwound direction will damage balance spring.

### ***CAUTION***

After removing cyclic grip, place plastic cap on exposed cyclic cross tube to prevent possible injury to left seat passenger.

2. To remove collective, push boot aft to expose locking pins. Depress locking pins and pull forward on stick. To install, use reverse procedure. It may be necessary to rotate stick slightly to allow pins to snap into place.

### ***CAUTION***

When collective is installed, ensure that both locking pins are fully engaged through holes on each side.

3. To remove tail rotor pedals, depress locking pin while twisting pedal counterclockwise, then pull up. To install, use reverse procedure. On later aircraft, a cover which is stowed under the floor scuff plate may be rotated up to cover the floor openings when the pedals are removed.

## **CONTROL FRICTION ADJUSTMENT**

Cyclic and collective controls are equipped with adjustable friction devices. The collective friction lever is located near the aft end of the pilot's collective. It is actuated aft to increase friction and forward to release it.

The cyclic friction knob is located left of the cyclic center post. Turning the knob clockwise applies friction to both longitudinal and lateral cyclic.

### ***CAUTION***

Control friction must be used with caution during flight. Excessive friction may make the helicopter difficult to control.

The pedals actuate push-pull controls connected directly to the tail rotor pitch control and do not incorporate any friction devices. An elastomeric trim spring provides a left pedal force to balance feedback forces in flight.

## **RPM GOVERNOR**

The governor maintains engine RPM by sensing changes and applying corrective throttle inputs through a friction clutch which can be easily overridden by the pilot. The governor is active only above 80% engine RPM and can be switched on or off using the toggle switch on the end of the right seat collective.

The governor is designed to assist in controlling RPM under normal conditions. It may not prevent over- or under-speed conditions generated by aggressive flight maneuvers.

### ***CAUTION***

When operating at high density altitudes, governor response rate may be too slow to prevent overspeed during gusts, pull-ups, or when lowering collective.



## **HYDRAULIC SYSTEM**

Hydraulically-boosted main rotor flight controls eliminate cyclic and collective feedback forces. The hydraulic system consists of a pump, three servos, a reservoir, and interconnecting lines. The working fluid is MIL-H-5606 and normal operating pressure is 450 to 500 psi. The pump is mounted on and driven by the main gearbox. A servo is connected to each of the three push-pull tubes that support the main rotor swashplate. The reservoir is mounted on the steel tube frame behind the main gearbox and includes a filter, pressure relief valve, and pilot-controlled pressure shut-off valve.

A sight gage for pre-flight fluid level checks is incorporated in the reservoir and is visible by opening a right side cowl door. A vented filler cap is located on top of the reservoir.

The pressure shut-off valve is solenoid-actuated and controlled by the hydraulic switch on the pilot's cyclic. The switch should be left ON during helicopter shutdown and start up except during the hydraulic system check.

### ***NOTE***

Electrical power is required to switch hydraulics OFF. Pulling HYD circuit breaker will NOT turn off hydraulics but will disable hydraulic switch.

Without hydraulic pressure, a large pilot input force is required to increase collective. Collective inputs also cause longitudinal cyclic forces which makes it difficult to maintain a steady hover. The servos have an irreversible feature to prevent rotor feedback forces from moving the controls. This allows the pilot to relax pressure on the controls in steady cruise flight. However, any cyclic input will cause the collective to lower and therefore the collective will have to be increased periodically.

## **ENGINE CONTROLS**

A twist-grip throttle control is located on each collective stick. The controls are interconnected and actuate the throttle valve through a mechanical linkage. The engine throttle is also correlated to collective inputs through a mechanical linkage. When the collective is raised, the throttle is opened and when the collective is lowered, the throttle is closed.

The electronic engine governor makes minor throttle adjustments by rotating the twist grip to maintain RPM within power-on limits. Manual manipulation of the twist grip is not typically required except during start up, shut down, autorotation practice, and emergencies.

An overtravel spring located in the throttle linkage allows the pilot to roll throttle off beyond the idle stop prior to a ground contact (run-on) autorotation landing. This prevents the throttle from opening when the collective is raised.

Correct throttle linkage adjustment may be verified during preflight by rolling the twist-grip through the overtravel spring and holding against the hard idle stop. The fuel control throttle arm should just barely start to move when the collective is raised full up.

Other engine controls include a mixture control on the console face, push-to-start buttons on pilot's cyclic and collective, an engine governor switch on pilot's collective, and a key-type ignition switch. The cyclic start button allows the pilot to maintain cyclic control during an air restart. The momentary (most clockwise) ignition switch position operates the auxiliary fuel pump for engine priming.

### ***CAUTION***

Starter buttons are active when master switch is on, even if ignition switch is off. Rotor brake should be left engaged after shutdown to disable starter button and reduce possibility of unintentional starter engagement.

## **CLUTCH ACTUATOR**

After the engine is started, it is coupled to the rotor drive system through vee-belts which are tensioned by raising the upper drive sheave. An electric actuator, located between the drive sheaves, raises the upper sheave when the pilot engages the clutch switch. The actuator senses compressive load (belt tension) and switches off when the vee-belts are properly tensioned. The clutch caution light illuminates whenever the actuator circuit is energized, either engaging, disengaging, or retensioning the belts. The light stays on until the belts are properly tensioned or completely disengaged.

Belt slack during engine start should be adjusted such that blades begin turning within five seconds of clutch engagement. Excessive slack may cause belts to jump out of sheave grooves during start. Periodic readjustment by a mechanic may be required as belts wear in service.

A fuse located on the test switch panel prevents an actuator motor overload from tripping the clutch circuit breaker. If the fuse blows, the actuator motor will stop but the clutch caution light will remain illuminated. An open circuit breaker removes power from both the motor and the light. With an open circuit breaker, no belt tensioning will occur, and the light will not function to indicate an abnormal condition.

### ***CAUTION***

Never take off while clutch caution light is on.

## **FUEL SYSTEM**

The fuel system includes main and auxiliary tanks, a shutoff valve control located between the front seats, a strainer (gascolator), an engine-driven pump, and an auxiliary (electric) pump. The fuel tanks have flexible bladders in aluminum enclosures. Fuel tank air vents are located inside the mast fairing. A fuel return line allows pump supply in excess of engine demand to return to the fuel tanks.

The auxiliary pump primes the engine for starting and runs in flight to provide fuel pump redundancy. The engine will function normally with either the engine-driven or auxiliary (electric) pump operating.

The ignition switch prime (momentary) position operates the auxiliary fuel pump for priming prior to engine start. After start, the pump runs continuously as long as the engine has oil pressure and the clutch switch is in the engage position.

A pressure switch on the gascolator illuminates the fuel filter caution light if the strainer becomes contaminated. Continued operation with an illuminated filter caution light may result in fuel starvation. A pressure switch downstream of the auxiliary fuel pump illuminates the aux fuel pump caution light if auxiliary pump output pressure is low. When the clutch switch is disengaged, the auxiliary pump is off and the aux fuel pump caution light should be illuminated. Proper mechanical fuel pump function is indicated by normal engine operation after engine start prior to clutch switch engagement and before shutdown while clutch switch is disengaged.

**FUEL SYSTEM (cont'd)**

Plunger-style drain valves are provided for the gascolator and for each fuel tank sump. The gascolator is located on the lower right side of the firewall and is drained by pushing up on the plastic tube which extends below the belly. Valves for both tanks are located inside the right cowl door below the auxiliary tank. Fuel samples are taken by extending the plastic tubes clear of the aircraft and pushing on the plungers. On newer helicopters, a glass tube stowed inside the upper, aft cowl door is provided which may be used to catch the fuel samples. Fuel should be sampled from all three locations prior to the first flight of the day and after refueling to verify no contamination and correct grade.

The fuel gages are electrically operated by float-type transmitters in the tanks. When the gages read E the tanks are empty except for a small quantity of unusable fuel. The low fuel caution light is actuated by a separate electric sender located on the bottom of the main tank.

The auxiliary tank is interconnected with the main tank and is located somewhat higher so it will become empty first while fuel still remains in the main tank. The fuel shutoff valve controls flow from both tanks to the engine.

## **ELECTRICAL SYSTEM**

A 28-volt DC electrical system which includes an alternator and a sealed lead-acid battery is standard. The battery is located either in the engine compartment, under the left front seat, or beneath the instrument console.

The circuit breaker panel is on the ledge just forward of the left front seat. Breakers are marked to indicate function and amperage. Inflight reset of circuit breakers is not recommended.

The battery switch controls the battery relay which disconnects the battery from the electrical system. A wire protected by a fuse near the battery bypasses the battery relay to allow both tachometers and the clock to continue to receive battery power with the battery switch off.

The alternator control unit protects the electrical system from overvoltage conditions. The ammeter indicates current to the battery ("—" indicates discharge). An ALT caution light or ammeter discharge indication in flight indicates low voltage and possible alternator failure. Turn off nonessential electrical equipment and switch alternator off then back on after one second to reset alternator control unit. If ALT light stays on or ammeter still indicates discharge, land as soon as practical.

### ***CAUTION***

Continued flight without functioning alternator can result in loss of power to tachometers, producing a hazardous flight condition.

### ***NOTE***

Except for emergency procedures, do not operate alternator with battery switched off. The battery helps protect electrical equipment from voltage spikes.

Later aircraft have an avionics master switch which controls power to the avionics bus. This allows all avionics to be switched on and off by a single switch.

**ELECTRICAL SYSTEM (cont'd)**

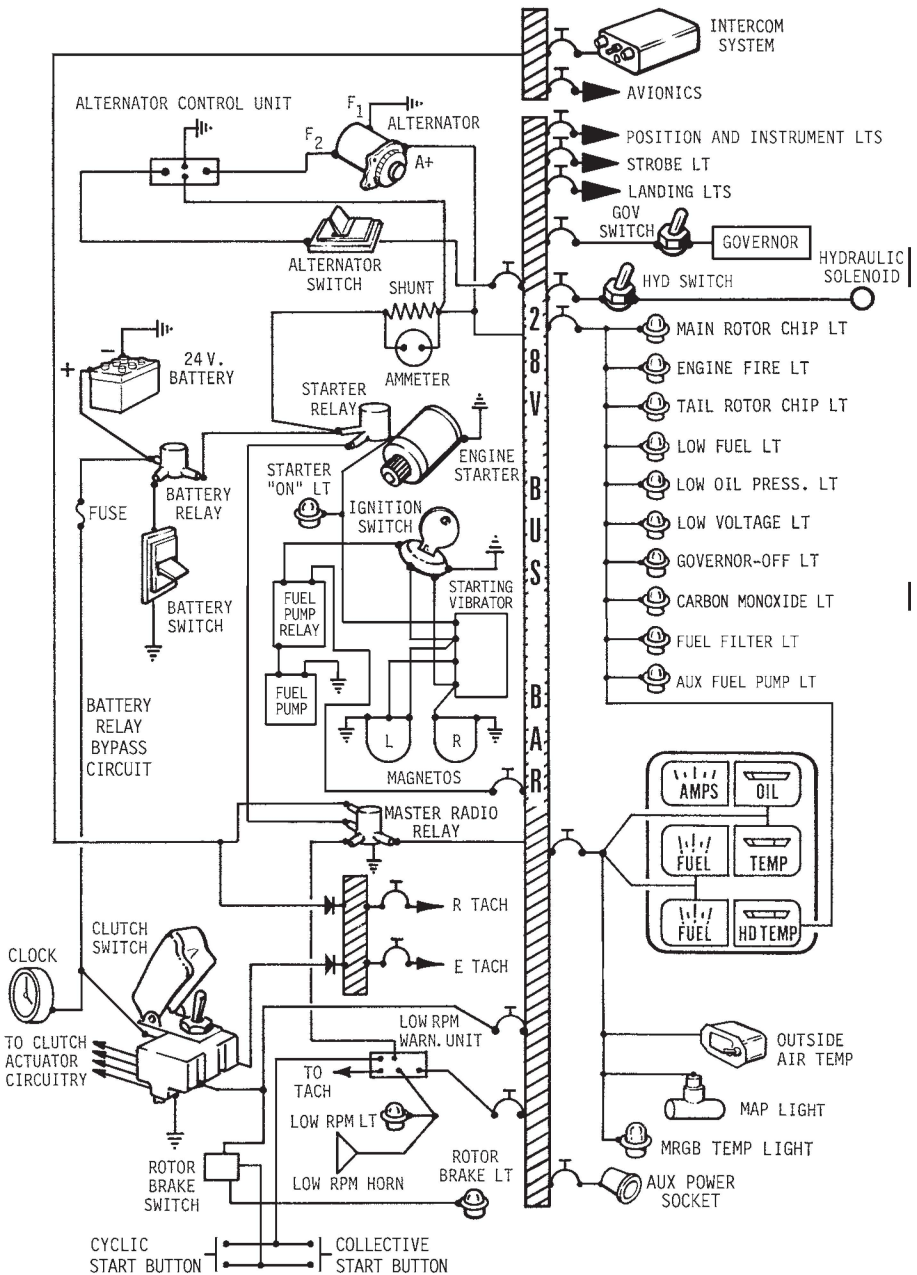

**ELECTRICAL SYSTEM (EARLIER AIRCRAFT)**

**ELECTRICAL SYSTEM (cont'd)**

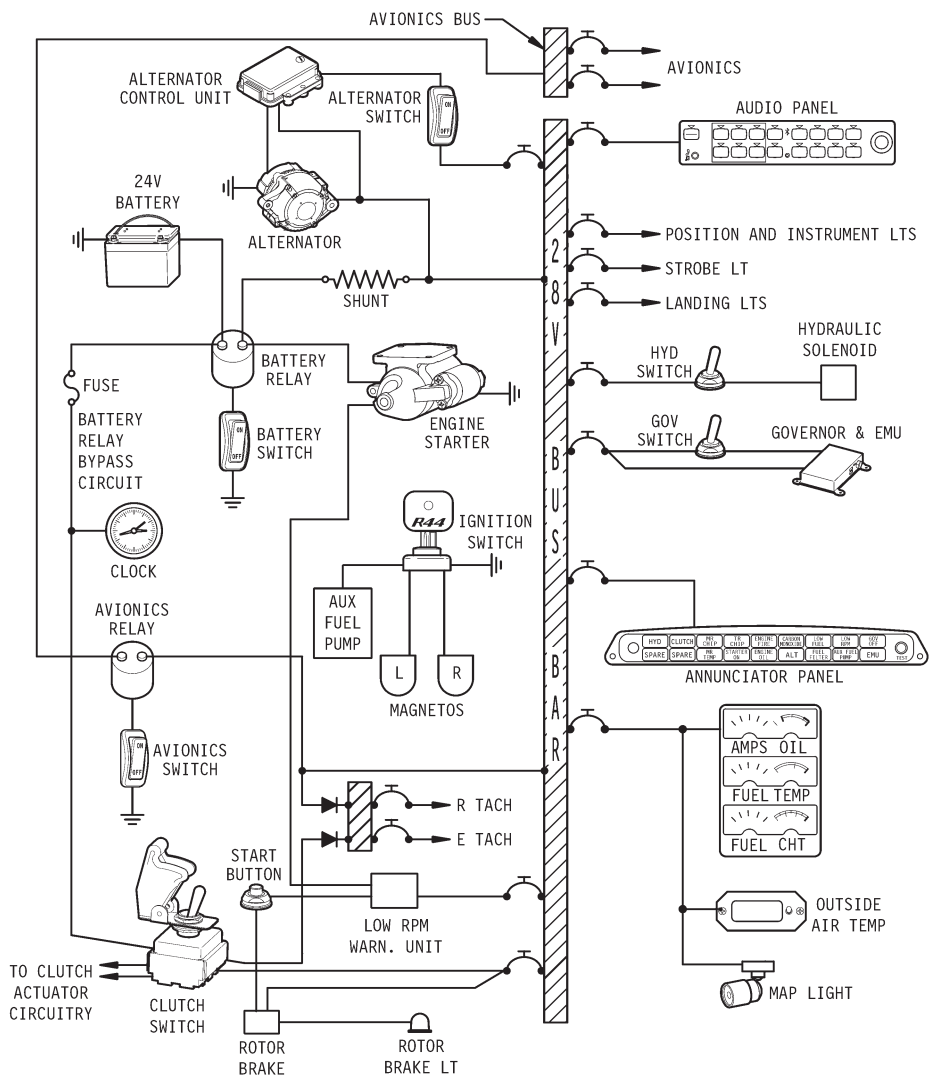

**ELECTRICAL SYSTEM (LATER AIRCRAFT)**



**ELECTRICAL SYSTEM (cont'd)**

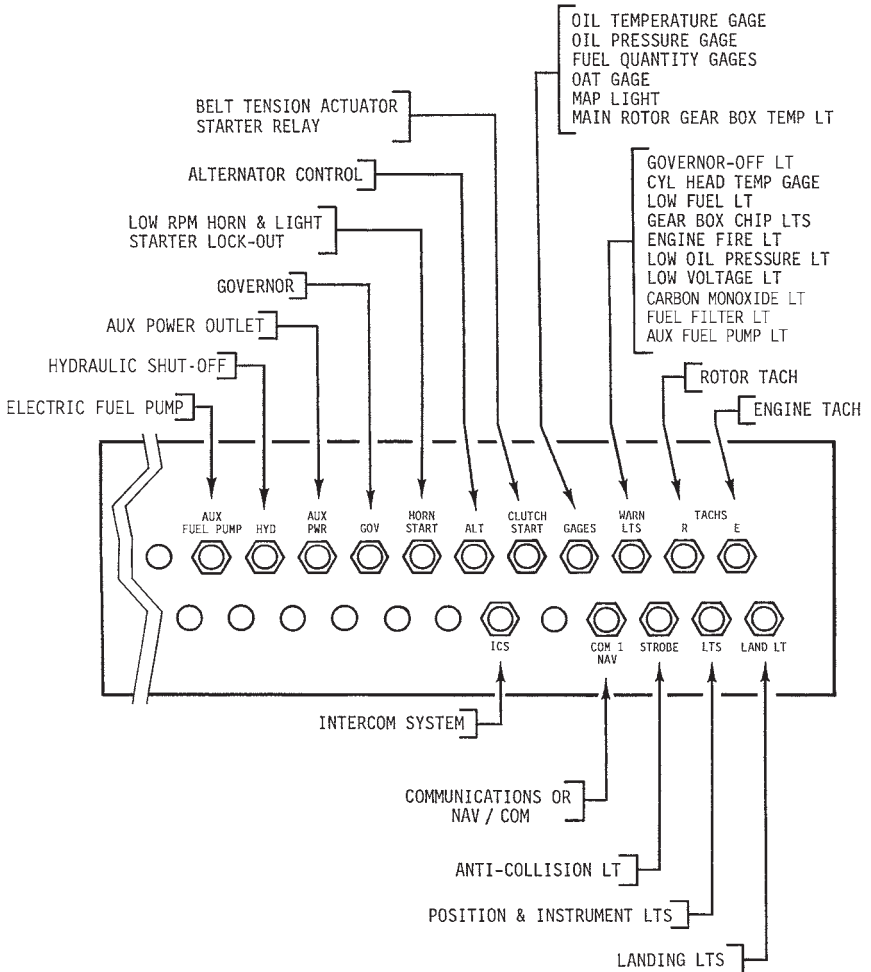

**CIRCUIT BREAKER PANEL – TYPICAL (EARLIER AIRCRAFT)**

**ELECTRICAL SYSTEM (cont'd)**

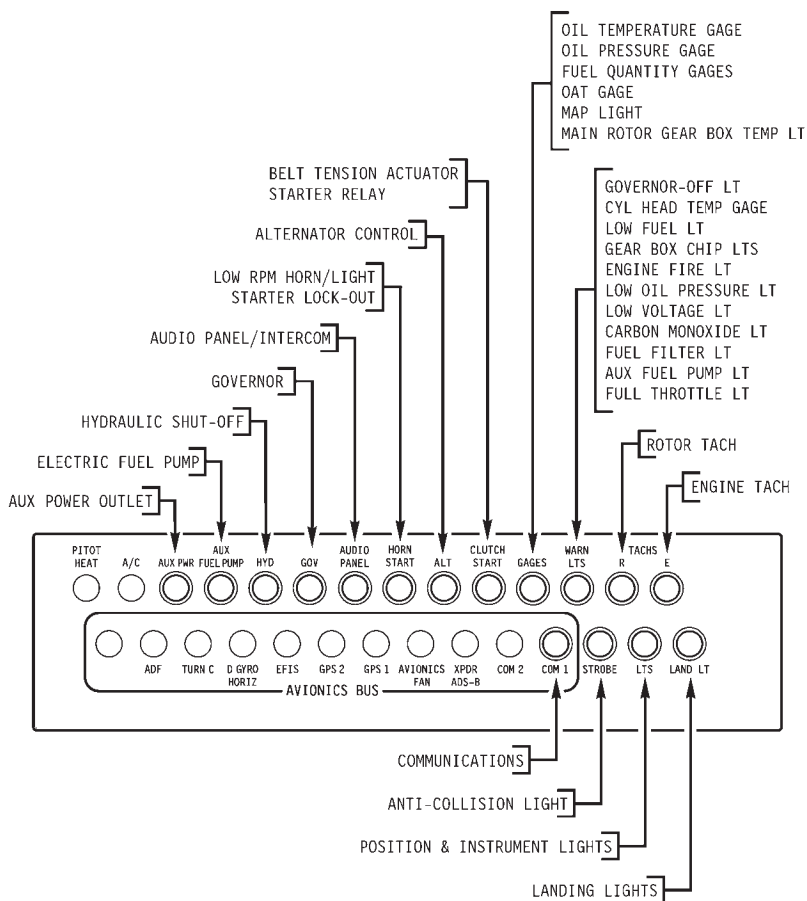

**CIRCUIT BREAKER PANEL – TYPICAL (LATER AIRCRAFT)**

## **LIGHTING SYSTEM**

A red anti-collision light is installed on the tailcone and is controlled by the strobe switch. Position lights are installed on each side of the cabin and in the tail and are controlled by the nav lights switch. Post and internal lights (earlier aircraft) or a light at the top of the windshield (later aircraft) illuminate the instruments. Instrument lighting is active when the nav lights switch is on and lighting is dimmed via the knob above the nav lights switch. An overhead map light mounted on a swivel is controlled by an adjacent switch. The map light may be used for emergency lighting of the instrument panel.

Two landing lights are installed in the nose at different vertical angles to increase the lighted area. One landing light switch controls both lights and is located on the cyclic center post.

### ***NOTE***

Landing lights operate only when clutch actuator switch is in the engage position.

### ***NOTE***

Continuous operation of landing and position lights in flight is recommended to promote collision avoidance.

An optional flashing light may be mounted on the tailcone in addition to the standard anti-collision light. On earlier aircraft, the optional light is controlled by the strobe switch and the standard light is powered whenever the battery switch is on. On later aircraft, the optional light is controlled by a separate switch.

### **EXTERNAL POWER RECEPTACLE (OPTIONAL)**

An optional 28-volt SAE AS35061-style external power receptacle is located inside the right engine cowl door. When the battery is switched on, the external power relay and the battery relay both close, connecting external power to the aircraft electrical system and battery. The external power relay will not close if reverse polarity is sensed by the receptacle.

A separate wire from the external power receptacle to the battery bypasses the external power and battery relays. This wire allows battery charging via the external receptacle with the battery switch off. A 20-amp (10 amp on earlier aircraft) circuit breaker at the receptacle opens if current exceeds normal charging levels, and a diode provides polarity protection.

To use ground power for engine starting, have ground personnel connect ground power to the external receptacle prior to engaging starter, disconnect after engine start, and latch cowl door. Starts using ground power assist follow the same procedure as normal starts.

### **INSTRUMENT PANEL**

Standard primary instruments include an airspeed indicator, engine and rotor dual tachometer, altimeter, manifold pressure gage, and magnetic compass. Engine gages include an ammeter, oil pressure, oil temperature, cylinder head temperature, and fuel quantity for main and aux tanks. Also standard are a clock, a digital outside air temperature gage, and a collective-activated hourmeter which may be used for recording time in service.

Views of typical instrument panels are given on the following pages. Additional views of panels with electronic flight displays are found in the Optional Avionics Supplement in Section 9. Pilots should familiarize themselves with panel layout and equipment installations for each specific aircraft that they fly.

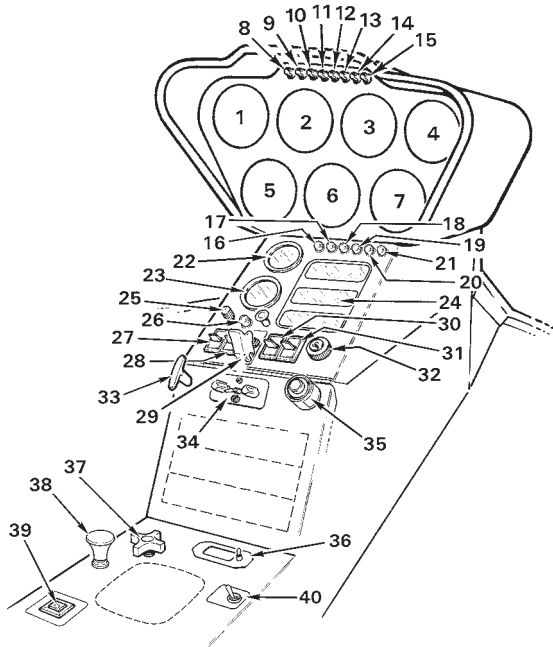

- |                             |                                 |
|-----------------------------|---------------------------------|
| 1. VERTICAL SPEED INDICATOR | 21. GOVERNOR-OFF LIGHT          |
| 2. OPTIONAL INSTRUMENT      | 22. HOURMETER                   |
| 3. AIRSPEED INDICATOR       | 23. CLOCK                       |
| 4. ENGINE AND ROTOR TACHS   | 24. ENGINE INSTRUMENTS          |
| 5. ALTIMETER                | 25. PANEL LIGHTS DIMMER         |
| 6. OPTIONAL INSTRUMENT      | 26. ROTOR BRAKE LIGHT           |
| 7. MANIFOLD PRESSURE GAGE   | 27. NAVIGATION LIGHTS SWITCH    |
| 8. CLUTCH ACTUATOR LIGHT    | 28. STROBE LIGHT SWITCH         |
| 9. M.R. GEARBOX TEMP LIGHT  | 29. CLUTCH ACTUATOR SWITCH      |
| 10. M.R. GEARBOX CHIP LIGHT | 30. ALTERNATOR SWITCH           |
| 11. CARBON MONOXIDE LIGHT   | 31. BATTERY SWITCH              |
| 12. STARTER-ON LIGHT        | 32. IGNITION AND PRIMER SWITCH  |
| 13. T.R. GEARBOX CHIP LIGHT | 33. CABIN AIR                   |
| 14. LOW FUEL LIGHT          | 34. INTERCOM                    |
| 15. LOW RPM LIGHT           | 35. MIXTURE CONTROL             |
| 16. FUEL FILTER LIGHT       | 36. OUTSIDE AIR TEMP/VOLTMETER  |
| 17. AUX FUEL PUMP LIGHT     | 37. CYCLIC FRICTION             |
| 18. ALT LOW VOLTAGE LIGHT   | 38. CABIN HEAT                  |
| 19. ENGINE FIRE LIGHT       | 39. ELT SWITCH (OPTIONAL)       |
| 20. OIL PRESSURE LIGHT      | 40. HEATED PITOT SWITCH (OPT'L) |

### INSTRUMENT PANEL – TYPICAL (EARLIER AIRCRAFT)

(Exact panel configuration may vary with optional equipment and date of helicopter manufacture.)

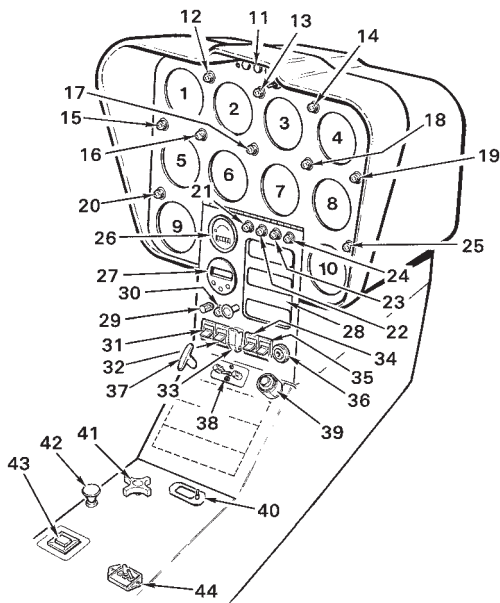

- |                             |                                |
|-----------------------------|--------------------------------|
| 1. ENGINE AND ROTOR TACHS   | 23. OIL PRESSURE LIGHT         |
| 2. AIRSPEED INDICATOR       | 24. GOVERNOR-OFF LIGHT         |
| 3. ARTIFICIAL HORIZON       | 25. FUEL FILTER LIGHT          |
| 4. ALTIMETER                | 26. HOURMETER                  |
| 5. MANIFOLD PRESSURE GAGE   | 27. CLOCK                      |
| 6. TURN COORDINATOR         | 28. ENGINE INSTRUMENTS         |
| 7. HSI                      | 29. PANEL LIGHTS DIMMER        |
| 8. VERTICAL SPEED INDICATOR | 30. ROTOR BRAKE LIGHT          |
| 9. OPTIONAL INSTRUMENT      | 31. NAVIGATION LIGHTS SWITCH   |
| 10. OPTIONAL INSTRUMENT     | 32. STROBE LIGHT SWITCH        |
| 11. MARKER BEACON           | 33. CLUTCH ACTUATOR SWITCH     |
| 12. M.R. GEARBOX TEMP LIGHT | 34. ALTERNATOR SWITCH          |
| 13. T.R. GEARBOX CHIP LIGHT | 35. BATTERY SWITCH             |
| 14. M.R. GEARBOX CHIP LIGHT | 36. IGNITION AND PRIMER SWITCH |
| 15. STARTER-ON LIGHT        | 37. CABIN AIR                  |
| 16. LOW RPM LIGHT           | 38. INTERCOM                   |
| 17. LOW FUEL LIGHT          | 39. MIXTURE CONTROL            |
| 18. CARBON MONOXIDE LIGHT   | 40. OUTSIDE AIR TEMP/VOLTMETER |
| 19. CLUTCH ACTUATOR LIGHT   | 41. CYCLIC FRICTION            |
| 20. AUX FUEL PUMP LIGHT     | 42. CABIN HEAT                 |
| 21. ALT LOW VOLTAGE LIGHT   | 43. ELT SWITCH (OPTIONAL)      |
| 22. ENGINE FIRE LIGHT       | 44. HSI SLAVE CONTROL          |

**OPTIONAL INSTRUMENT PANEL (EARLIER AIRCRAFT)**

(Exact panel configuration may vary with optional equipment and date of helicopter manufacture.)

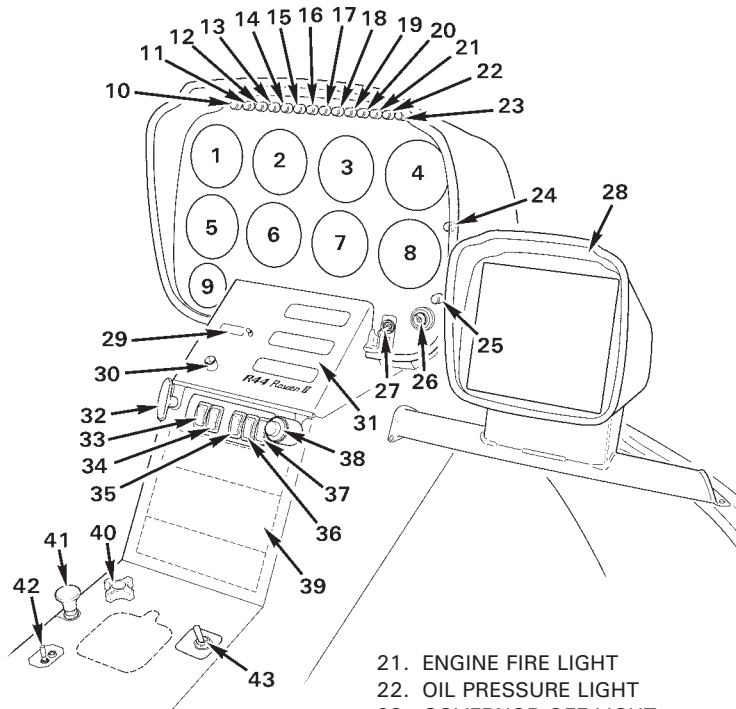

- 1. VERTICAL SPEED INDICATOR
- 2. OPTIONAL INSTRUMENT
- 3. AIRSPEED INDICATOR
- 4. ENGINE AND ROTOR TACHS
- 5. OPTIONAL INSTRUMENT
- 6. OPTIONAL INSTRUMENT
- 7. ALTIMETER
- 8. MANIFOLD PRESSURE GAGE
- 9. CLOCK
- 10. CLUTCH ACTUATOR LIGHT
- 11. M.R. GEARBOX TEMP LIGHT
- 12. M.R. GEARBOX CHIP LIGHT
- 13. CARBON MONOXIDE LIGHT
- 14. STARTER-ON LIGHT
- 15. T.R. GEARBOX CHIP LIGHT
- 16. LOW FUEL LIGHT
- 17. LOW RPM LIGHT
- 18. FUEL FILTER LIGHT
- 19. AUX FUEL PUMP LIGHT
- 20. ALT LOW VOLTAGE LIGHT

- 21. ENGINE FIRE LIGHT
- 22. OIL PRESSURE LIGHT
- 23. GOVERNOR-OFF LIGHT
- 24. FULL THROTTLE LIGHT
- 25. ROTOR BRAKE LIGHT
- 26. IGNITION SWITCH
- 27. CLUTCH ACTUATOR SWITCH
- 28. PILOT'S SIDE CONSOLE (OPT'L)
- 29. OUTSIDE AIR TEMP/VOLTMETER
- 30. PANEL LIGHTS DIMMER
- 31. ENGINE INSTRUMENTS
- 32. CABIN AIR
- 33. NAVIGATION LIGHTS SWITCH
- 34. ANTI-COLLISION LIGHT SWITCH
- 35. AVIONICS MASTER SWITCH
- 36. ALTERNATOR SWITCH
- 37. BATTERY SWITCH
- 38. MIXTURE CONTROL
- 39. AVIONICS STACK
- 40. CYCLIC FRICTION
- 41. CABIN HEAT
- 42. ELT SWITCH (OPTIONAL)
- 43. PITOT HEAT SWITCH (OPT'L)

**INSTRUMENT PANEL – TYPICAL (LATER AIRCRAFT)**

(Exact panel configuration may vary with optional equipment and date of helicopter manufacture.)

THIS PAGE INTENTIONALLY BLANK



## **AUDIO SYSTEM**

A four-place intercom/audio system is standard and is controlled by a small control panel above the avionics stack. The ICS volume knob controls intercom volume but does not affect radio volume. The VOX squelch knob is used to set the threshold volume at which the intercom is activated. When the VOX knob is turned fully clockwise, keying is required to activate the intercom.

A toggle switch allows selection of PILOT ISO mode in which the pilot is connected only to the radio while the copilot and rear passengers remain connected to each other via the intercom. A music input jack is located on the aft seat console. This input is muted when the intercom is active, when transmitting, and during reception of radio signals.

Headset jacks are located in the ceiling near each seat. The cyclic grips are equipped with trigger-style intercom/transmit switches. The first trigger switch detent activates the intercom and the second detent transmits. Additional intercom buttons are located inboard of the rear seats and on the left forward floor or seat support.

Audio control panels from several manufacturers are offered as options in place of the standard intercom system. Pilots should consult the manufacturer's operating instructions if an audio panel is installed.

## **OPTIONAL AVIONICS**

A wide range of optional avionics are available for the R44. It is not practical to provide a description of all equipment in this manual. All aircraft are delivered with the manufacturers' operating manuals for each piece of installed equipment. Pilots are referred to the manufacturers' manuals for detailed operating instructions. Additional information for more complex options such as primary or multi-function displays (PFDs/MFDs) may be found in the Optional Avionics Supplement in Section 9. Good practice dictates becoming familiar with installed equipment before operating an aircraft.

## **PITOT-STATIC SYSTEM**

The pitot-static system supplies air pressure to operate the airspeed indicator, altimeter, and vertical speed indicator. The pitot tube is located on the front edge of the mast fairing. The static sources are located on each side of the cabin aft of the rear doors.

Water can be drained from pitot-static lines by removing the plastic drain plugs which are accessible through the forward inspection panel on the underside of the cabin. Draining lines should be required only if the airspeed indicator or altimeter appears erratic.

Pitot and static sources should be inspected frequently to verify no bugs or other obstructions.

## **DUAL TACHOMETER**

An electronic engine and rotor dual tachometer is standard. Engine tachometer signal is provided by magneto breaker points. Rotor tachometer signal is provided by two magnetic senders at the main gearbox drive yoke. Each tachometer is on a separate circuit with its own circuit breaker. With battery and alternator switches off, the tachometers continue to receive power from the battery through a bypass circuit as long as the clutch actuator switch is in the engage position.

### ***NOTE***

Do not stow helicopter with clutch switch engaged. The tachometers are powered with the clutch engaged and will discharge the battery.

**WARNING AND CAUTION LIGHTS**

Earlier aircraft have individual warning and caution lights as shown in the views under INSTRUMENT PANEL of this section. Later aircraft have an annunciator panel consisting of illuminated segments located at the top of the main instrument panel. A typical annunciator panel is shown below.



**ANNUNCIATOR PANEL**

The CHIP lights are illuminated by magnetic chip detectors in each gearbox which collect metallic particles in order to complete an electric circuit. The MR TEMP light is illuminated by a temperature switch located on the main gearbox near the input pinion.

The CLUTCH light indicates that the clutch actuator is operating. The ENGINE FIRE light is illuminated by a temperature switch located at the forward end of the horizontal firewall. The OIL light (ENGINE OIL segment) is activated by a pressure switch which is independent of the pressure sender. The ALT light warns of a possible alternator failure.

The LOW FUEL light is activated by a float switch in the main tank which is independent of the fuel quantity senders. The LOW RPM light and horn are activated by a sensor at the aft end of the main gearbox when driveline speed is below 97% RPM. The CARBON MONOXIDE light is activated by a sensor above the pilot's heater outlet. The GOV OFF light indicates the RPM governor is switched off. The STARTER ON light indicates the engine starter motor is engaged.

The FUEL FILTER light warns of possible filter contamination. The AUX FUEL PUMP light monitors fuel pressure from the auxiliary pump and illuminates due to pump failure or when the clutch switch is not engaged. The FULL THROTTLE light is activated by a switch in the throttle linkage and indicates that the engine is near full throttle. The BRAKE light indicates that the rotor brake is engaged.

### **WARNING AND CAUTION LIGHTS (Cont'd)**

Aircraft with annunciator panels include HYD and EMU segments. The HYD segment illuminates when the hydraulic system is switched off. The EMU (Engine Monitoring Unit) segment indicates EMU status and will illuminate only when the test button is depressed.

The annunciator panel includes a test button which should cause all segments on the panel, as well as the FULL THROTTLE and BRAKE lights, to illuminate when depressed. (Earlier aircraft have test buttons for certain lights on the horizontal firewall aft of the aux fuel tank.) The LOW FUEL segment takes approximately two seconds before it illuminates due to a time delay in the circuit (to prevent sloshing fuel from giving a false indication). If LOW FUEL illuminates immediately after the test button is depressed, a fault is indicated and should be investigated by a qualified mechanic. The EMU takes approximately ten seconds to perform a self test after the battery is switched ON before it will illuminate. The test button may be used on the ground or in flight to verify all circuits are functioning.

### **AUDIO ALERTS**

All R44 helicopters have a low-RPM horn which sounds when rotor RPM is below 97%. The horn is muted when the collective is fully down. On earlier aircraft, the horn is provided by one or two speakers in the side of the instrument console. On later aircraft, a tone generator in the audio system provides the horn through crew headsets.

Later aircraft include a high rotor RPM alert through the headsets. A warble tone (high/low tone) indicates rotor RPM is approaching 108%. A test button on the instrument panel permits pre-flight or in-flight testing of the high-RPM alert.

Additional audio alerts may be provided in the headsets depending on optional equipment installed, such as terrain warnings, traffic warnings, and autopilot modes.

## **ENGINE MONITORING UNIT**

Later aircraft are equipped with an Engine Monitoring Unit (EMU), which is a digital recording device within the engine RPM governor control box. The EMU continuously monitors engine and rotor speed, engine oil temperature, cylinder head temperature, manifold pressure, ambient pressure, and outside air temperature.

EMU status is indicated by the EMU segment on the annunciator panel. The EMU segment will only illuminate while the annunciator panel test button is depressed. The EMU requires approximately ten seconds to complete a self-test after the aircraft battery is switched on. Once the self test is complete, steady illumination of the annunciator means normal EMU operation. A slowly flashing indication (once every two seconds) or no illumination means there is a fault in the EMU's senders or circuitry. A fast flashing indication (four times per second) is given if the EMU has detected an exceedance. EMU data can be downloaded to a computer with the appropriate software. A fault or exceedance should be investigated and the indication reset by a qualified mechanic prior to the next flight. Current exceedances may be reviewed (but not reset) on an Apple mobile device using an application available through the Robinson website.

The EMU is intended to be used only as a maintenance aid. It remains the pilot's responsibility to report any observed exceedances.

## **CABIN HEATING AND VENTILATION**

Fresh air vents are located in each door and in the nose. Door vents are opened and closed using the knob near the vent door hinge. A rotating knob is provided to lock vents closed. For maximum ventilation, open door vents wide during hover but only one inch or less during cruise. The rotating knob can be used to hold vents partially open.

The fresh air inlet in the nose is opened by pulling the vent handle on the console face. Rotating the vent handle clockwise will lock its position. Air from the nose inlet is directed along the inside surface of the windshield for defogging as well as for ventilation.

The cabin heater consists of a muffler heat shroud, a control valve at the firewall, outlets forward of the tail rotor pedals and in the rear footwells, and interconnecting ducting. A heater control knob located to the left of the cyclic center post actuates the valve which directs heat either into the cabin or out an overboard discharge on the cabin underside.

### ***CAUTION***

In case of an in-flight engine fire, cabin heat should be turned off to seal cabin area from engine compartment.

## **SEATS, BELTS, AND BAGGAGE**

The seats are not adjustable but the pilot-side pedals are adjustable. Each helicopter is supplied with a removable back cushion to position the pilot farther forward. This allows shorter pilots to reach the pedals, the cyclic grip in its most forward position, and controls on the center console.

Heated seat bottoms and backrests for the forward seats are an option. Switches to control low and high heat settings are located at the bottom of the avionics console. The seat heaters operate only when the alternator switch is in the ON position to reduce the likelihood of inadvertently draining the battery before the engine is started.

### **SEATS, BELTS, AND BAGGAGE (cont'd)**

Each seat is equipped with a combined lap belt and inertia reel shoulder strap. The inertia reel is normally free but will lock if there is sudden movement as would occur in an accident.

Four- or five-point harnesses are optional for the front seats. The lap belts on these harnesses should be adjusted to eliminate slack. On five-point harnesses, the lower strap should be adjusted as necessary to ensure that the buckle does not interfere with the cyclic in the full aft position. Later harnesses are equipped with a webbing stop located above the inertia reel. The stop limits shoulder strap retraction and should be adjusted so the straps are comfortable without excessive slack.

Optional anchor loops located in the cabin ceiling above the door posts provide attachment points for a safety tether for equipment or occupants during doors-off operation.

A baggage compartment is located under each seat. Seat cushions hinge forward for access.

### **LANDING GEAR**

A skid-type landing gear is used. Most hard landings will be absorbed elastically. However, in an extremely hard landing, the struts will hinge up and outward as the crosstube yields (becomes permanently bent) to absorb the impact. Slight crosstube yielding is acceptable. However, yielding which allows the tail skid to be within 30 inches of the ground when the helicopter is sitting empty on level pavement requires crosstube replacement.

The four landing gear struts are fitted with aerodynamic fairings to reduce air drag. The helicopter is approved to fly with or without the fairings installed.

Abrasion-resistant wear shoes are mounted on the bottom of the skids. These shoes should be inspected periodically, particularly if autorotation landings have been performed. Have skid shoes replaced whenever the thinnest point in the wear area is less than 0.05 inches (1.3 mm).

### **LANDING GEAR (cont'd)**

Optional mirrors may be installed near the forward end of one or both landing gear skid tubes. Each mirror is mounted on a friction ball joint and may be adjusted to the desired angle.

### **ROTOR BRAKE**

The rotor brake is mounted on the aft end of the main gearbox and is actuated by a cable connected to a pull handle located on the cabin ceiling. To stop the rotor, use the following procedure:

1. After pulling mixture off, wait at least 30 seconds.
2. Pull brake handle forward and down using moderate force (approximately 10 lb).
3. After rotor stops, it is recommended to use the rotor brake as a parking brake by hooking bead chain in slot in bracket.

The brake must be released before starting the engine. When the brake is engaged, the starter buttons are disabled.

### ***CAUTION***

Applying rotor brake without waiting at least 30 seconds after engine stops or using a force which stops rotor in less than 20 seconds may damage brake shoes.



## **CARBON MONOXIDE DETECTOR**

The carbon monoxide (CO) detector indicates elevated cabin CO levels. CO is an odorless, toxic gas present in engine exhaust which causes headaches, drowsiness, and possible loss of consciousness. CO levels may become elevated due to an exhaust leak or exhaust recirculation during prolonged hovering.

The CO detector system consists of a sensor above the pilot's heater outlet and a caution light. A system check (light flashes twice) is performed each time power is switched on. A sensor malfunction is indicated by a continuing flash every four seconds.

If the caution light illuminates, shut off heater and open nose and door vents as required to ventilate the cabin. If hovering, land or transition to forward flight. If symptoms of CO poisoning (headache, drowsiness, dizziness) accompany caution light, land immediately. Have exhaust system inspected before next flight.

Many chemicals can damage the CO sensor. Avoid use of solvents, detergents, or aerosol sprays near the sensor. Temporarily tape off openings in top and bottom of sensor housing when cleaning cabin interior.

## **ADS-B EQUIPMENT**

An Automatic Dependent Surveillance Broadcast (ADS-B) capable transponder is installed on later aircraft. The transponder transmits GPS position information to air traffic control to supplement radar/transponder information.

ADS-B "Out" capability is required for operation in certain airspace. ADS-B equipment installed at the factory meets the requirements of 14 CFR § 91.227. ADS-B Out operation is mostly automatic and requires little pilot action. Malfunctions will be annunciated on the transponder and/or GPS. Refer to transponder and GPS manufacturer's documentation for further details on ADS-B Out equipment operation.

### ***NOTE***

ADS-B Out equipment installed at the factory operates on frequency 1090 MHz. This frequency is also accepted for ADS-B Out equipment in most countries outside the United States.

### ***NOTE***

The ability to turn off ADS-B Out broadcasts is provided via transponder controls. However, ADS-B Out is required in certain airspace. ADS-B Out should not be selected off unless directed by air traffic control.

ADS-B equipment may also receive traffic information from other ADS-B equipped aircraft and (depending on specific equipment and country of operation) additional traffic and weather information from ground stations. ADS-B equipment that receives information is known as ADS-B "In", is not required by regulations, and is optional.

ADS-B In functionality requires a suitable display such as a moving map GPS or Multi-Function Display (MFD). ADS-B In equipment installed at the factory receives both approved US frequencies (978 MHz and 1090 MHz). Refer to avionics manufacturer's documentation for details on ADS-B In equipment operation.

### **EMERGENCY LOCATOR TRANSMITTER (OPTIONAL)**

The Emergency Locator Transmitter (ELT) installation consists of a transmitter with internal battery pack, an external antenna, and a remote switch/annunciator. The transmitter is mounted to the upper steel tube frame and is accessible through the aft, upper cowl door. The remote switch/annunciator is located left of the cyclic stick.

The ELT is operated by a switch on the transmitter and a remote switch in the cockpit. The transmitter switch has been secured in the AUTO or ARM position at installation and should always be in this position for flight. The remote switch/annunciator is a three position switch with indicator light. This switch should also be in the AUTO or ARMED (middle) position for flight. With both switches set to AUTO/ARM, the ELT will begin transmitting when subjected to a high "G" load. When the unit is transmitting, the red indicator light illuminates.

Moving the remote switch to ON activates the transmitter. Use the ON position if an emergency landing is imminent and time permits.

If the ELT is inadvertently activated, use the RESET position of the remote switch to stop transmission and reset the unit. The red indicator will extinguish when unit is reset.

For more detailed instructions on ELT operation, maintenance, and required tests, refer to manufacturer's instructions supplied with the unit.

**ACCESSORY MOUNTS (OPTIONAL)**

Provisions for mounting small, portable items are an option. The provisions use mounting bars located forward of the pilot's seat, the copilot's seat, or both. The bars are fitted with one or more clamp assemblies which are compatible with a variety of commercially available accessory mounts. There is a 10 lb total weight limit for items attached to each bar. USB and cigarette-lighter-style power outlets are installed near the inboard end of the mounting bars. The power outlets are protected by the Aux Power circuit breaker and in-line fuses and are placarded with voltage/current ratings. Wire clamps and a pocket for securing excess wire are also provided.

The accessory mounts are intended to provide a safe means of mounting small items such as portable electronic devices. The mounting bar, clamp assembly, and power outlets are approved as part of the aircraft type design, but any items attached are the responsibility of the pilot in command under appropriate operating rules. Ensure that any items attached are secure and do not interfere with flight controls or primary field of view. Route any wires through the wire clamps or secure them to the bar with cable ties or tape.

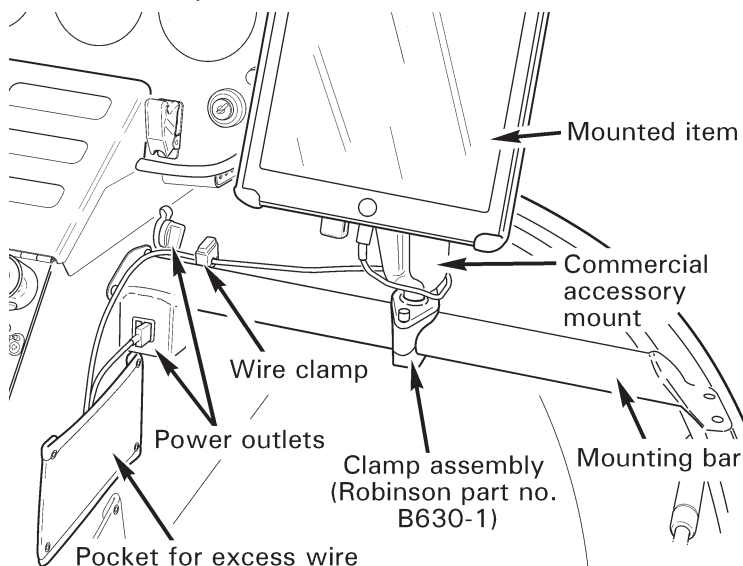

### COCKPIT CAMERA (OPTIONAL)

An optional video camera may be installed in the cabin ceiling. The camera records 4K video, intercom/comm audio, and GPS position both internally and to a removable flash drive inserted in the front of the camera housing. The internal memory retains only recent video and is not user accessible. Recording starts automatically when the helicopter battery is switched on and stops when it is switched off.

Recording to the flash drive can be stopped or audio muted using the record and audio switches on the front of the camera housing. Do not remove the flash drive while a recording is in progress as this will corrupt the video file. To remove a flash drive when the helicopter battery switch is on, first stop the recording using the record switch.

A blue flashing light on the camera housing indicates video is being recorded to the flash drive. A green steady light indicates the camera is powered and operating normally. The green light will change to an amber flashing light if an internal camera fault is detected, in which case video may not be recorded.

Video recorded on the flash drive can be viewed on a Windows PC or Mac computer. Video is recorded in sequential 4 GB files with each file approximately 25 minutes in length. Video files are labeled HELICAM\_XXXX.MP4, where XXXX is a sequential number. GPS position and altitude are optionally displayed in the video and are also recorded separately to files labeled HELICAM\_XXXX.GPX. A 128 GB flash drive (as supplied with helicopter) will record approximately 10 hours of video. When full, the earliest video file is overwritten with the last recording.

#### **NOTE**

Flash drives must meet the criteria described in the *Cockpit Camera User Guide* in order to function reliably.

### **COCKPIT CAMERA (OPTIONAL) (cont'd)**

The *Cockpit Camera User Guide* is available on the Robinson website, [www.robinsonheli.com](http://www.robinsonheli.com), and includes additional information on camera operation, playback options, and troubleshooting.

### **CYCLIC GUARD (OPTIONAL)**

The optional cyclic guard is a bar that extends from the inboard corner of the left front seat to the instrument console. It is intended to act as a barrier to help prevent inadvertent interference with the cyclic control. The guard also provides a hand grip for a passenger's right hand.

In order to access the under seat compartment with the guard installed, pull the silver spring knob at the forward end of the guard and allow the aft end to rotate down away from the seat hinge. To re-secure the guard, lift the aft end and allow the spring knob to lock back in place.

It is recommended that the guard be installed whenever a non-pilot passenger occupies the left front seat. A pilot flying from the left seat may find that the guard contacts the right leg when feet are on the pedals. The guard should be removed prior to flight if the pilot finds it objectionable.