

**LOG OF PAGES APPROVED BY FAA
TYPE CERTIFICATE NO. H11NM**

	Page No.	Approval Date	Page No.	Approval Date
Cover Log of Pages	i	29 Apr 16		
	ii	26 Jan 24		
Section 2 Limitations	2-i	29 Apr 16	2-7	21 Oct 16
	2-1	29 Apr 16	2-8	29 Apr 16
	2-2	7 May 19	2-9	29 Apr 16
	2-3	29 Apr 16	2-10	7 May 18
	2-4	29 Apr 16	2-11	29 Apr 16
	2-5	26 Jan 24	2-12	29 Apr 16
	2-6	7 May 18		
Section 3 Emergency Procedures	3-i	11 May 20	3-6	29 Apr 16
	3-1	29 Apr 16	3-7	7 May 19
	3-2	29 Apr 16	3-8	29 Apr 16
	3-3	29 Apr 16	3-9	29 Apr 16
	3-4	29 Apr 16	3-10	11 May 20
	3-5	17 Dec 19	3-11	11 May 20
Section 4 Normal Procedures	4-i	21 Oct 16	4-9	21 Oct 16
	4-1	7 May 18	4-10	7 May 19
	4-2	7 May 18	4-11	29 Apr 16
	4-3	17 Nov 21	4-12	29 Apr 16
	4-4	7 May 18	4-13	21 Oct 16
	4-5	7 May 18	4-14	11 May 20
	4-6	29 Apr 16	4-15	29 Apr 16
	4-7	11 May 20	4-16	29 Apr 16
	4-8	17 Nov 21		
Section 5 Performance	5-i	29 Apr 16	5-5	21 Oct 16
	5-1	17 Nov 21	5-6	29 Apr 16
	5-2	29 Apr 16	5-7	26 Jan 24
	5-3	29 Apr 16	5-8	29 Apr 16
	5-4	21 Oct 16		
Section 9 Supplements	9-i	17 Nov 21		

Approved By: LAN-GLENN V TO Digitally signed by LAN-GLENN V TO
Date: 2024.01.26 08:25:19 -08'00' , FTE, AIR-713 for,
 Manager, Flight Test & Human Factors Branch, AIR-710
 Federal Aviation Administration

Date of Approval: 26 JAN 2024

**LOG OF PAGES
NOT REQUIRING FAA APPROVAL**

	Page No.	Revision Date	Page No.	Revision Date
Section 1 General	1-i	26 Jan 24	1-5	29 Apr 16
	1-1	29 Apr 16	1-6	29 Apr 16
	1-2	29 Apr 16	1-7	29 Apr 16
	1-3	26 Jan 24	1-8	29 Apr 16
	1-4	26 Jan 24		
Section 6 Weight and Balance	6-i	29 Apr 16	6-5	29 Apr 16
	6-1	29 Apr 16	6-6	26 Jan 24
	6-2	29 Apr 16	6-7	26 Jan 24
	6-3	29 Apr 16	6-8	29 Apr 16
	6-4	26 Jan 24		
Section 7 Systems Description	7-i	17 Nov 21	7-16	17 Nov 21
	7-1	29 Apr 16	7-17	17 Nov 21
	7-2	29 Apr 16	7-18	7 May 18
	7-3	17 Nov 21	7-19	29 Apr 16
	7-4	17 Nov 21	7-20	11 May 20
	7-5	29 Apr 16	7-21	11 May 20
	7-6	7 May 18	7-22	11 May 20
	7-7	7 May 18	7-23	26 Jan 24
	7-8	7 May 18	7-24	17 Nov 21
	7-9	7 May 18	7-25	17 Nov 21
	7-10	29 Apr 16	7-26	11 May 20
	7-11	17 Nov 21	7-27	17 Nov 21
	7-12	17 Nov 21	7-28	17 Nov 21
	7-13	17 Nov 21	7-29	17 Nov 21
	7-14	17 Nov 21	7-30	26 Jan 24
7-15	17 Nov 21	7-31	17 Nov 21	
Section 8 Handling and Maintenance	8-i	17 Nov 21	8-8	7 May 19
	8-1	7 May 19	8-9	11 May 20
	8-2	7 May 19	8-10	11 May 20
	8-3	17 Dec 19	8-11	7 May 19
	8-4	7 May 19	8-12	7 May 19
	8-5	7 May 19	8-13	7 May 19
	8-6	7 May 19	8-14	17 Nov 21
	8-7	7 May 19	8-15	17 Nov 21
Section 10 Safety Tips	10-i	21 Oct 16	10-4	21 Oct 16
	10-1	29 Apr 16	10-5	17 Nov 21
	10-2	21 Oct 16	10-6	22 Jan 24
	10-3	29 Apr 16		

SECTION 1

GENERAL

CONTENTS

	Page
Introduction	1-1
Cautions and Notes	1-2
External Dimensions	1-3
Descriptive Data	1-4
Performance Definitions	1-6
Weight and Balance Definitions	1-7
Conversion Tables	1-8

INTENTIONALLY BLANK

EXTERNAL DIMENSIONS

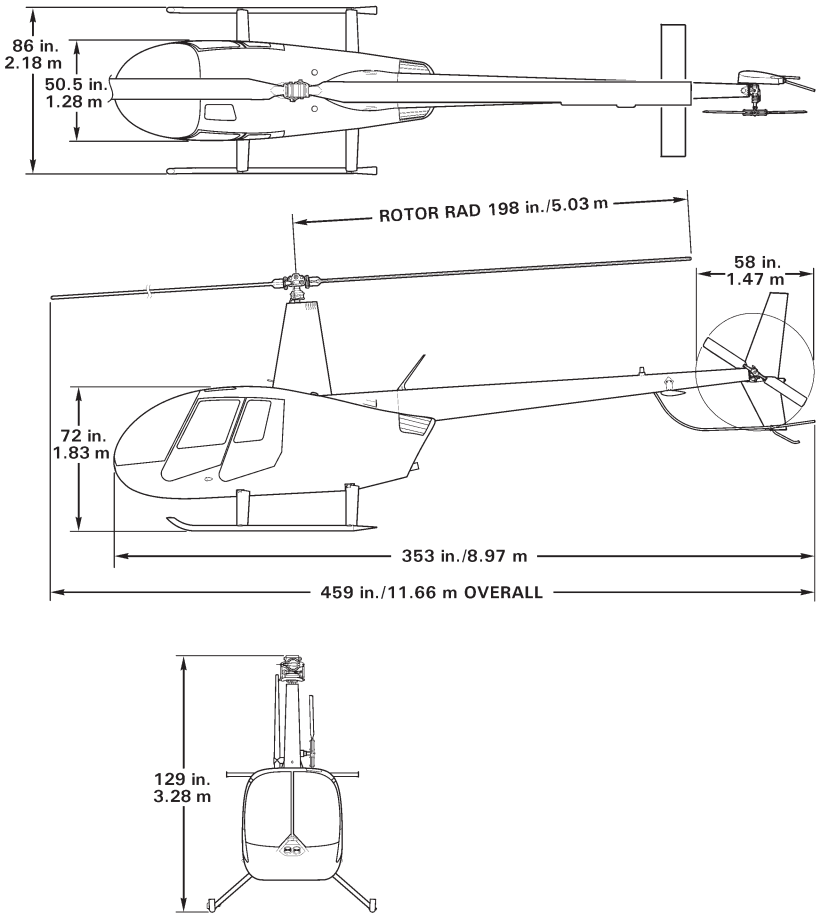

**R44 CADET EXTERNAL DIMENSIONS
(LATER AIRCRAFT SHOWN)**

DESCRIPTIVE DATA

MAIN ROTOR

Articulation	Free to teeter and cone, rigid inplane
Number of Blades	2
Diameter	33 feet
Blade Chord	10.0 inches inboard, 10.6 inches outboard
Blade Twist	-6 Degrees
Tip Speed at 102% RPM	705 feet per second

TAIL ROTOR

Articulation	Free to teeter, rigid inplane
Number of Blades	2
Diameter	58 inches
Blade Chord	5.1 inches (constant)
Blade Twist	0
Precone Angle	1 Degree
Tip Speed at 102% RPM	614 feet per second

DRIVE SYSTEM

Engine to Upper Sheave:	Four double Vee-belts with 0.778:1 speed reducing ratio
Upper Sheave to Drive Line:	Sprag-type overrunning clutch
Drive Line to Main Rotor:	Spiral-bevel gears with 11:57 speed reducing ratio
Drive Line to Tail Rotor:	Spiral-bevel gears with 31:27 speed increasing ratio

FLIGHT AND MANEUVER LIMITATIONS

Aerobatic flight prohibited.

CAUTION

Abrupt control inputs may produce high fatigue stresses and cause catastrophic failure of a critical component.

Low-G cyclic pushovers prohibited.

CAUTION

A pushover (forward cyclic maneuver) performed from level flight or following a pullup causes a low-G (near weightless) condition which can result in catastrophic loss of lateral control. To eliminate a low-G condition, immediately apply gentle aft cyclic. Should a roll commence during a low-G condition, apply gentle aft cyclic to reload rotor before applying lateral cyclic to stop roll.

Flight prohibited with governor selected off, with exceptions for in-flight system malfunction or emergency procedures training.

Flight in known icing conditions prohibited.

Maximum operating density altitude 14,000 feet.

Maximum operating altitude 9000 feet AGL to allow landing within 5 minutes in case of fire.

Alternator, RPM governor, low rotor RPM warning system, OAT gage, and hydraulic control system must be operational for dispatch.

Minimum crew is one pilot in the right seat. A flight instructor may act as pilot in command from the left seat. Solo flight from right seat only.

Maximum occupancy is two people. Occupants in aft cabin prohibited.

Left seat belt must be buckled.

Operation up to 100 KIAS approved with any combination of cabin doors removed. Loose items in cabin must be properly secured during doors-off flight.

A functioning headset must be worn by each pilot.

KINDS OF OPERATION LIMITATIONS

VFR day and night operations are approved.

VFR operation at night is permitted only when landing, navigation, instrument, and anti-collision lights are operational. Orientation during night flight must be maintained by visual reference to ground objects illuminated solely by lights on the ground or adequate celestial illumination.

Note: There may be additional requirements in countries outside the United States.

FUEL LIMITATIONS

APPROVED FUEL GRADES

Grade	Color	Specification
100	Green	ASTM D910
100LL	Blue	
100VLL	Blue	
UL 91	Clear to Yellow (no dye)	ASTM D7547
UL 94		
HJELMCO 91/96 UL	Clear to Yellow (no dye)	Hjelmco Oil, Inc. Sollentuna, Sweden
91	Yellow	TU 38.5901481-96 Ukrainian National Standard
B91/115	Green	GOST 1012-72 Russian National Standard
B95/130	Amber	

FUEL CAPACITY

	Total Capacity US gallons (liters)	Usable Capacity US gallons (liters)
Main tank	30.5 (115)	29.5 (112)
Auxiliary tank	17.2 (65)	17.0 (64)
Combined capacity	47.7 (180)	46.5 (176)

NOISE CHARACTERISTICS

The following noise levels comply with 14 CFR Part 36, Appendix J and ICAO Annex 16, Chapter 11 noise requirements and were obtained from FAA-approved data from actual noise tests.

Model: R44
 Engine: Lycoming O-540-F1B5
 Gross Weight: 2200 lbs (998 kg)

Configuration	V _H KTAS	Flyover Sound Exposure Level dB(A)
Earlier Version	107	78.2
Later Version	106	79.2

Notes:

Earlier version — Horizontal Stabilizer is mounted adjacent to tail gearbox.

Later version — Horizontal Stabilizer is mounted under tailcone forward of tail rotor.

These noise levels meet the requirements for a Stage 3 helicopter as defined in 14 CFR Part 36.

NOTE

No determination has been made by the Federal Aviation Administration that the noise levels of this aircraft are or should be acceptable or unacceptable for operation at, into, or out of any airport.

THIS PAGE INTENTIONALLY BLANK

WEIGHT AND BALANCE RECORD (cont'd)

WEIGHT AND BALANCE RECORD
(Continuous History of Changes in Structure or Equipment Affecting Weight and Balance)

DATE		DESCRIPTION OF ARTICLE OR MODIFICATION		WEIGHT CHANGE				RUNNING BASIC EMPTY WEIGHT														
				ADDED (+) REMOVED (-) WEIGHT (lb)	LONGITUDINAL Arm (in.)	Moment (in.-lb)	LATERAL (+ = RIGHT SIDE) Arm (in.)	Moment (in.-lb)	WEIGHT (lb)	LONGITUDINAL Arm (in.)	Moment (in.-lb)	LATERAL Arm (in.)	Moment (in.-lb)									
			HELICOPTER AS WEIGHED																			

LOADING INSTRUCTIONS

The following table may be used when calculating loaded helicopter weight and CG position.

COMMON ITEM WEIGHT & CG

Item	Weight (lb)	Longitudinal arm (in.)	Lateral arm (in.) (+ = right side)
Pilot (right seat)		49.5*	+ 12.2
Passenger (left seat)		49.5*	- 10.4
Baggage under seats		44.0	± 11.5
Aft baggage compartments and deck		78.0	± 12.2
Main fuel**		106.0	- 13.5
Aux fuel**		102.0	+ 13.0
Forward doors	7.5 each	49.4	± 24.0
Aft doors	7.0 each	75.4	± 23.0
Removable controls (cyclic, collective, pedals)	2.0	31.0	- 13.0
Items on accessory mount bars		25.0	± 14.0

* If additional backrest cushion is used, subtract thickness of compressed cushion.

** A longitudinal arm of 104.5 in. may be used for combined main and aux fuel.

LOADING INSTRUCTIONS (cont'd)

The following sample calculation demonstrates how to determine loaded helicopter weight and center of gravity. A worksheet is provided on the page following the sample calculation for a weight and balance calculation for your helicopter. Calculated weight and balance must be compared with the CG limits given in Section 2 to determine safe loading. Both takeoff and empty fuel conditions must be within limits.

Lateral CG usually falls well within limits for conventional loadings. If an unusual lateral installation or loading occurs, lateral CG should be checked against the CG limits given in Section 2. The lateral reference datum is the aircraft centerline with items to the right positive and items to the left negative.

LOADING INSTRUCTIONS (cont'd)

SAMPLE LOADING CALCULATION

Item	Weight (lb)	Location		Moment	
		Long. Arm (in.)	Lat. Arm (in.) + = Right Side	Long. (in.-lb)	Lat. (in.-lb)
Basic empty weight	1460	106.2	0.2	155,052	292
Remove forward right door	-7.5	49.4	24.0	-371	-180
Remove forward left door		49.4	-24.0		
Remove aft right door		75.4	23.0		
Remove aft left door		75.4	-23.0		
Remove left seat controls		31.0	-13.0		
Pilot (right seat)	170	49.5	12.2	8415	2074
Passenger (left seat)	170	49.5	-10.4	8415	-1768
Baggage under right seat		44.0	11.5		
Baggage under left seat		44.0	-11.5		
Aft right compartment and deck	20	78.0	12.2	1560	244
Aft left compartment and deck	10	78.0	-12.2	780	-122
Items on accessory mount bars	5	25.0	14.0	125	70
Zero usable fuel weight and CG*	1827.5	95.2	0.3	173,976	610
Usable main fuel at 6 lb/gal.	177	106.0	-13.5	18,762	-2390
Usable aux fuel at 6 lb/gal.	102	102.0	13.0	10,404	1326
Takeoff Gross Weight and CG*	2106.5	96.4	-0.2	203,142	-454

* CG location (arm) for loaded helicopter is determined by dividing total moment by total weight.

LOADING INSTRUCTIONS (cont'd)

LOADING CALCULATION WORKSHEET

Item	Weight (lb)	Location		Moment	
		Long. Arm (in.)	Lat. Arm (in.) + = Right Side	Long. (in.-lb)	Lat. (in.-lb)
Basic empty weight					
Remove forward right door		49.4	24.0		
Remove forward left door		49.4	- 24.0		
Remove aft right door		75.4	23.0		
Remove aft left door		75.4	- 23.0		
Remove left seat controls		31.0	- 13.0		
Pilot (right seat)		49.5	12.2		
Passenger (left seat)		49.5	- 10.4		
Baggage under right seat		44.0	11.5		
Baggage under left seat		44.0	- 11.5		
Aft right compartment and deck		78.0	12.2		
Aft left compartment and deck		78.0	- 12.2		
Items on accessory mount bars		25.0			
Zero usable fuel weight and CG*					
Usable main fuel at 6 lb/gal.		106.0**	- 13.5		
Usable aux fuel at 6 lb/gal.		102.0**	13.0		
Takeoff Gross Weight and CG*					

* CG location (arm) for loaded helicopter is determined by dividing total moment by total weight.

** A longitudinal arm of 104.5 in. may be used for combined main and aux fuel. Do not use combined main and aux fuel if calculating lateral arm.

THIS PAGE INTENTIONALLY BLANK

CABIN HEATING AND VENTILATION

Fresh air vents are located in each forward door and in the nose. Door vents are opened and closed using the knob near the vent door hinge. A rotating knob is provided to lock vents closed. For maximum ventilation, open door vents wide during hover but only one inch or less during cruise. The rotating knob can be used to hold vents partially open.

The fresh air inlet in the nose is opened by pulling the vent handle on the console face. Rotating the vent handle clockwise will lock its position. Air from the nose inlet is directed along the inside surface of the windshield for defogging as well as for ventilation.

The cabin heater consists of a muffler heat shroud, a control valve at the firewall, outlets forward of the tail rotor pedals and in the rear floor area, and interconnecting ducting. A heater control knob located on the console face actuates the valve which directs heat either into the cabin or out an overboard discharge on the cabin underside.

CAUTION

In case of an in-flight engine fire, cabin heat should be turned off to seal cabin area from engine compartment.

SEATS, BELTS, AND BAGGAGE

The seats are not adjustable but the pilot-side pedals are adjustable. Each helicopter is supplied with a removable back cushion to position the pilot farther forward. This allows shorter pilots to reach the pedals, the cyclic grip in its most forward position, and controls on the center console.

Heated seat bottoms and backrests are an option. Switches to control low and high heat settings are located at the bottom of the avionics console. The seat heaters operate only when the alternator switch is in the ON position to reduce the likelihood of inadvertently draining the battery before the engine is started.

SEATS, BELTS, AND BAGGAGE (cont'd)

Both seats are equipped with a combined lap belt and inertia reel shoulder strap. The inertia reel is normally free but will lock if there is sudden movement as would occur in an accident.

Five-point harnesses are optional. The lap belts on these harnesses should be adjusted to eliminate slack. On five-point harnesses, the lower strap should be adjusted as necessary to ensure that the buckle does not interfere with the cyclic grip in the full aft position. A webbing stop located above the inertia reel limits shoulder strap retraction and should be adjusted so the straps are comfortable without excessive slack.

Optional anchor loops located in the cabin ceiling above the door posts provide attachment points for a safety tether for equipment or occupants during doors-off operation.

A baggage compartment is located under each seat. Seat cushions hinge forward for access. Two additional compartments are located under the rear deck. The rear deck covers hinge forward and have lockable latches.

LANDING GEAR

A skid-type landing gear is used. Most hard landings will be absorbed elastically. However, in an extremely hard landing, the struts will hinge up and outward as the crosstube yields (becomes permanently bent) to absorb the impact. Slight crosstube yielding is acceptable. However, yielding which allows the tail skid to be within 30 inches of the ground when the helicopter is sitting empty on level pavement requires crosstube replacement.

The four landing gear struts are fitted with aerodynamic fairings to reduce air drag. The helicopter is approved to fly with or without the fairings installed.

Abrasion-resistant wear shoes are mounted on the bottom of the skids. These shoes should be inspected periodically, particularly if autorotation landings have been performed. Have skid shoes replaced whenever the thinnest point in the wear area is less than 0.05 inches (1.3 mm).

ACCESSORY MOUNTS (OPTIONAL)

Provisions for mounting small, portable items are an option. The provisions use mounting bars located forward of the pilot's seat, the copilot's seat, or both. The bars are fitted with one or more clamp assemblies which are compatible with a variety of commercially available accessory mounts. There is a 10 lb total weight limit for items attached to each bar. USB and cigarette-lighter-style power outlets are installed near the inboard end of the mounting bars. The power outlets are protected by the Aux Power circuit breaker and in-line fuses and are placarded with voltage/current ratings. Wire clamps and a pocket for securing excess wire are also provided.

The accessory mounts are intended to provide a safe means of mounting small items such as portable electronic devices. The mounting bar, clamp assembly, and power outlets are approved as part of the aircraft type design, but any items attached are the responsibility of the pilot in command under appropriate operating rules. Ensure that any items attached are secure and do not interfere with flight controls or primary field of view. Route any wires through the wire clamps or secure them to the bar with cable ties or tape.

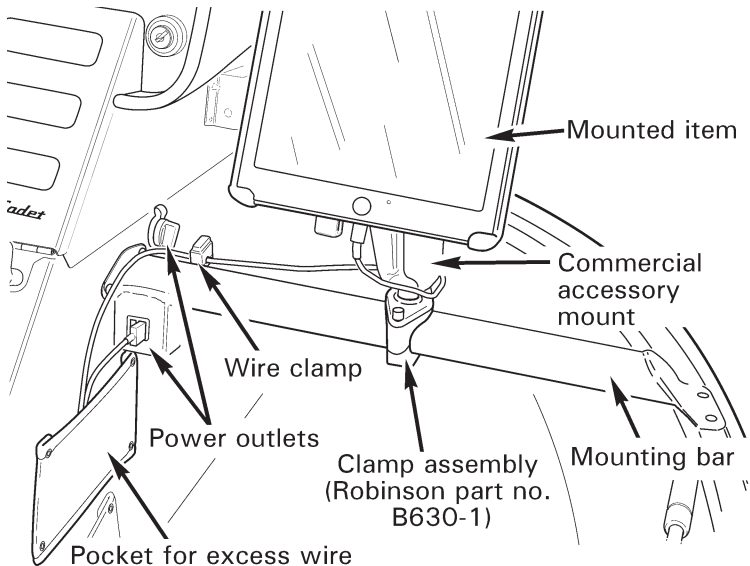

COCKPIT CAMERA (OPTIONAL)

An optional video camera may be installed in the cabin ceiling. The camera records 4K video, intercom/comm audio, and GPS position both internally and to a removable flash drive inserted in the front of the camera housing. The internal memory retains only recent video and is not user accessible. Recording starts automatically when the helicopter battery is switched on and stops when it is switched off.

Recording to the flash drive can be stopped or audio muted using the record and audio switches on the front of the camera housing. Do not remove the flash drive while a recording is in progress as this will corrupt the video file. To remove a flash drive when the helicopter battery switch is on, first stop the recording using the record switch.

A blue flashing light on the camera housing indicates video is being recorded to the flash drive. A green steady light indicates the camera is powered and operating normally. The green light will change to an amber flashing light if an internal camera fault is detected, in which case video may not be recorded.

Video recorded on the flash drive can be viewed on a Windows PC or Mac computer. Video is recorded in sequential 4 GB files with each file approximately 25 minutes in length. Video files are labeled HELICAM_XXXX.MP4, where XXXX is a sequential number. GPS position and altitude are optionally displayed in the video and are also recorded separately to files labeled HELICAM_XXXX.GPX. A 128 GB flash drive (as supplied with helicopter) will record approximately 10 hours of video. When full, the earliest video file is overwritten with the last recording.

NOTE

Flash drives must meet the criteria described in the *Cockpit Camera User Guide* in order to function reliably.

FAA APPROVED
R44, R44 II, R44 CADET
PILOT'S OPERATING HANDBOOK

HELISAS AUTOPILOT SUPPLEMENT

This supplement must be included in the FAA-approved Pilot's Operating Handbook when the HeliSAS autopilot is installed.

The information contained herein supplements or supersedes the basic manual only in those areas listed in this supplement. For limitations, procedures, and performance information not contained in this supplement, consult the basic Pilot's Operating Handbook.

APPROVED BY: 
for Manager, Flight Test Branch, ANM-160L
Federal Aviation Administration, LAACO
Transport Airplane Directorate

DATE: September 8, 2014

LOG OF REVISIONS

Page No.	Date	Page No.	Date
9-13.1	15 Mar 22	9-13.8*	15 Mar 22
9-13.2*	15 Mar 22	9-13.9*	15 Mar 22
9-13.3	15 Mar 22	9-13.10*	15 Mar 22
9-13.4	15 Mar 22	9-13.11*	15 Mar 22
9-13.5	15 Mar 22	9-13.12*	15 Mar 22
9-13.6*	15 Mar 22	9-13.13*	15 Mar 22
9-13.7*	15 Mar 22		

* Manufacturer's data, not FAA approved.

REVISIONS
APPROVED BY: LAN-GLENN V TO Digitally signed by LAN-GLENN V TO
Date: 2022.03.15 07:03:08 -07'00'
Manager, West Flight Test Section, AIR-716
Federal Aviation Administration
Los Angeles *Acting,*

DATE: 15 MAR 2022

SECTION 1: GENERAL

INTRODUCTION

This supplement contains the changes and additional data applicable when the HeliSAS autopilot is installed.

There are two versions of the HeliSAS autopilot. The earlier version (designated Version 51) has a BC (backcourse) button on the control panel. The later version (designated Version 52) replaces the BC button with a SPD (speed) button on the control panel.

The autopilot's primary Stability Augmentation System (SAS) mode maintains a steady helicopter attitude by applying corrective inputs to the cyclic. Additional modes providing heading hold, altitude hold, airspeed control (Version 52), and navigation functionality are also selectable. The autopilot does not provide any collective or pedal inputs. The system is designed as a "fly through" system meaning the pilot can override as desired for maneuvering without disengaging the system. Only a few pounds of force at the cyclic are required for override, and the system will not disconnect due to pilot cyclic inputs.

CAUTION

The autopilot is intended to enhance safety by reducing pilot workload. It is not a substitute for adequate pilot skill nor does it relieve the pilot of the responsibility to monitor the flight controls and maintain adequate outside visual reference.

SECTION 2: LIMITATIONS

FLIGHT AND MANEUVER LIMITATIONS

Pilot's hand must be on cyclic grip under the following conditions:

During autopilot engagement or intentional disengagement

At altitudes less than 200 feet AGL

Minimum altitude for use of autopilot ALT mode is 200 feet AGL.

For practice instrument approaches, minimum altitude for use of autopilot VRT mode is 50 feet AGL

SECTION 3: EMERGENCY PROCEDURES

AUTOPILOT DISENGAGEMENT OR FAILURE

The autopilot is designed to automatically disengage if the system detects a fault. Disengagement is normally indicated by four beeps in the headset. If the autopilot does not automatically disengage, failure may be recognized by erratic cyclic control motion, abnormal cyclic stick forces, or deviations in pitch or roll.

1. Continue flight using manual control. If autopilot has not disengaged, manually disengage using cyclic AP OFF button or control panel SAS button.
2. If SAS annunciator on control panel is steady white, re-engagement may be attempted at pilot's discretion.

CAUTION

Although unlikely, it is possible for certain faults to cause disengagement without the four-beep aural warning.

SECTION 3: EMERGENCY PROCEDURES (cont'd)

AUTOPILOT DISENGAGEMENT OR FAILURE (cont'd)

CAUTION

Due to the unstable nature of helicopters, autopilot disengagement requires immediate pilot attention. Always monitor helicopter attitude and flight controls, and be prepared to take manual control.

NOTE

The system automatically switches off all modes except SAS mode at airspeeds below 44 KIAS or above 130 KIAS, accompanied by a single beep. This is by design and not a system failure. The high speed limit is not intended to provide V_{ne} protection. It is the pilot's responsibility to observe V_{ne} limits.

SECTION 4: NORMAL PROCEDURES

GENERAL

Autopilot controls and operating modes are described in Section 7, Systems Description.

NOTE

Cyclic friction must be fully off for autopilot to work properly. Cyclic friction will degrade autopilot performance.

SECTION 4: NORMAL PROCEDURES (cont'd)

STARTING ENGINE AND RUN-UP

After "Hydraulic system", add:

- Autopilot Check
- Airspeed and altitude bugs Set (Version 52)

NOTE

For autopilot check, wear headset and ensure cyclic friction is off. Engage SAS mode. Verify cyclic exhibits centering tendency and SAS annunciator on control panel turns green. Disengage. Verify 4 beeps in headset, cyclic reverts to normal hydraulic system feel, and SAS annunciator turns white.

TAKEOFF PROCEDURE

Autopilot SAS mode may be engaged as desired on the ground or at any time during the takeoff procedure. Re-trim as necessary to eliminate undesirable cyclic forces.

CRUISE

Add:

Engage autopilot modes as desired. In SAS mode, re-trim as necessary to eliminate undesirable cyclic forces.

CAUTION

It is the pilot's responsibility to monitor flight controls, aircraft flightpath, traffic, and terrain even while the autopilot is engaged. The autopilot is designed to disengage in the event of a fault. Be prepared to take control if required.

SECTION 5: PERFORMANCE

No change.

SECTION 6: WEIGHT AND BALANCE

No change.

SECTION 7: SYSTEMS DESCRIPTION

AUTOPILOT

The HeliSAS autopilot system consists of two electric servomotors, a flight control computer, an autopilot control panel, and control buttons on the cyclic grip. One servomotor controls pitch and is installed in the control tunnel forward of the cyclic stick. The other servomotor controls roll and is installed under the pilot's seat. The servomotors are connected to the cyclic through electromagnetic clutches.

The flight control computer is installed on the forward panel under the pilot's seat, and the autopilot control panel is installed in the avionics stack.

The autopilot senses aircraft attitude using a combination of sensors in the flight control computer and an independent onboard attitude source such as the Attitude Heading Reference System (AHRS) for the Primary Flight Display (PFD). The computer then sends signals to the servomotors which are connected to the bottom of the cyclic in the control tunnel.

The primary autopilot mode is Stability Augmentation System (SAS) mode which maintains a steady helicopter attitude by applying corrective inputs to the cyclic. This is felt as a light cyclic centering force. Additional modes may be layered on top of SAS mode and are described below. The pilot can override as desired for maneuvering without disengaging the system. Only a few pounds of force at the cyclic are required for override, and the system will not disconnect due to pilot cyclic inputs.

The control panel has a row of buttons to control autopilot modes and annunciators to indicate mode status. A dark annunciator indicates that a mode is off, a white annunciator indicates that a mode is armed or on standby, and a green annunciator indicates that a mode is active.

SECTION 7: SYSTEMS DESCRIPTION (cont'd)

AUTOPILOT (cont'd)

When the avionics master is switched on, the autopilot performs a self-test and then enters SAS standby mode. All of the control panel indicators flash alternating white and green during the self-test. Four headset beeps occur at the beginning of the self-test as a check of the aural warning function. The SAS annunciator on the control panel turns steady white when the self-test is complete.

NOTE

Autopilot will not enter standby mode if attitude indicator is not functioning or indicated bank angle is greater than 6 degrees.

The autopilot SAS mode is engaged either by pressing the SAS button on the control panel or by pressing the TRIM button on the cyclic for more than 1.25 seconds. Additional modes are engaged by pressing the appropriate button on the control panel. The additional modes are disabled and will not engage at airspeeds below 44 KIAS or above 130 KIAS.

To disengage any mode, push the appropriate button on the control panel

NOTE

Disengaging SAS mode will also disengage all other modes.

Modes may also be disengaged using the AP OFF button on the cyclic. If only SAS mode is engaged, push the AP OFF button once to disengage. If additional modes are engaged, push the AP OFF button once to disengage all modes except SAS and a second time to disengage SAS mode, or push and hold the AP OFF button to disengage all modes including SAS

SECTION 7: SYSTEMS DESCRIPTION (cont'd)

AUTOPILOT (cont'd)

NOTE

SAS disengagement should always be accompanied by four beeps in the headset. If beeps do not occur, maintenance is required.

Safety monitors automatically disengage individual modes or the entire system if a fault is detected. Automatic disengagement of SAS mode (or the entire system) is indicated by four beeps in the headset. Automatic disengagement of any mode other than SAS is indicated by a single beep in the headset. There is no audio indication for intentional disengagement of modes other than SAS.

NOTE

The system also automatically reverts to SAS mode at airspeeds below 44 KIAS or above 130 KIAS, accompanied by a single beep. The high speed limit is not intended to provide V_{ne} protection. It is the pilot's responsibility to observe V_{ne} limits.

The TRIM button is used to re-set the target attitude (to re-trim) while in SAS mode. Use a small amount of force to override the autopilot and then push and release the TRIM button at the new desired condition. If the force to override is objectionable, the TRIM button may be held down during maneuvers. The system will re-trim to the attitude at which the TRIM button is released. For Version 52, stick forces felt during override will gradually wash out to near zero without use of TRIM button if override is maintained.

NOTE

The system will not re-trim to angles more than approximately 10° in pitch or roll.

SECTION 7: SYSTEMS DESCRIPTION (cont'd)

AUTOPILOT (cont'd)

NOTE

When engaging SAS mode from standby, for angles of less than approximately 10° in pitch and roll, SAS holds the current angles. If either pitch or roll is larger than approximately 10°, the system assumes an unusual attitude and gently levels the helicopter.

The autopilot is protected by a dedicated circuit breaker on the avionics bus (autopilot is not powered with the avionics master switch off).

Heading Mode (HDG) – maintains the heading selected by the heading bug on the directional gyro or Horizontal Situation Indicator (HSI) display. Aircraft can be steered using the heading bug.

Altitude Mode (ALT) – maintains altitude at the time of engagement or of last TRIM button release. The target altitude is reset each time the TRIM button is pressed and released.

NOTE

The autopilot uses pitch attitude to maintain altitude or follow an approach glidepath. It does not have any control of power setting. The pilot must manage power with the collective to control speed and rate of climb or descent. Make small, smooth power changes to allow the system to adjust to new power settings.

SECTION 7: SYSTEMS DESCRIPTION (cont'd)

AUTOPILOT (cont'd)

Navigation Mode (NAV) – tracks the active GPS or VLOC course displayed on the Course Deviation Indicator (CDI). If no CDI is installed, NAV will only track the active GPS course displayed on the GPS.

NAV may be armed prior to intercepting the active course. NAV annunciator is white when NAV is armed and turns green at course intercept. If HDG is active when NAV is armed, the autopilot will fly the selected heading until course intercept. If HDG is not active, the autopilot will select a 45° intercept angle.

Vertical Navigation Mode (VRT) – tracks an ILS glideslope or GPS approach vertical guidance. Arm VRT (annunciator turns white when armed) prior to intercepting the glidepath. VRT annunciator will turn green at glidepath intercept.

NOTE

Pushing the ALT button while VRT is armed or active will turn off VRT. VRT must be re-armed or re-engaged as desired.

NOTE

Reducing power to approach setting just prior to glidepath intercept is recommended.

Speed Mode (SPD) (Version 52 only)

Speed mode uses cyclic pitch to control airspeed. Exact behavior varies with configuration of airspeed and altitude bugs on the PFD as described below.

The altitude bug is displayed above the altitude tape and the airspeed bug is displayed above the airspeed tape. The appearance of all dashes or a blank field indicates a bug is not set.

SECTION 7: SYSTEMS DESCRIPTION (cont'd)

AUTOPILOT (cont'd)

Speed Mode (SPD) (Version 52 only) (cont'd)

If an airspeed bug is not set, selecting SPD holds the current airspeed. The target speed is reset each time the trim button is pressed and released.

If an airspeed bug is set, selecting SPD holds airspeed at the bug setting. Changing the bug will change the target airspeed.

If an altitude bug is set, selecting SPD will also arm ALT (ALT LED white) for altitude capture. The mode will switch from SPD to ALT if the selected altitude is crossed. There will be a brief period in capture mode with the ALT LED flashing white/green.

NOTE

Do not change the selected altitude during ALT capture (ALT LED flashing white/green). System may pitch up or down to chase bug and may not capture altitude.

NOTE

Different brands of PFD behave differently in terms of bug settings at power up and how bugs are manually set. Refer to PFD manufacturer's documents for proper use. Verify desired bug settings before engaging SPD mode.

SECTION 7: SYSTEMS DESCRIPTION (cont'd)

AUTOPILOT (cont'd)

Backcourse Mode (BC) (Version 51 only) – reverse CDI sensing for backcourse approaches. Course on HSI should be set so that tail of course pointer points toward runway (set to inbound front course).

Airspeed Protection (Version 52 only) – Minimizes the possibility of the ALT mode to fly the helicopter to an airspeed below 44 KIAS due to insufficient power, or the VRT mode to fly the helicopter to an airspeed above 130 KIAS due to excess power when flying a precision approach glideslope. When triggered, it causes the longitudinal mode to change from ALT (at low airspeed) or VRT (at high airspeed) to SAS mode with a commanded pitch attitude of 2 degrees nose down. Since the mode change is not commanded by the pilot, a single warning beep is annunciated.

REMOVABLE FLIGHT CONTROLS

On later aircraft, disconnect the electrical connector for the left-hand trim button located near the quick release pin before removing the left cyclic grip. Reconnect the connector when installing the left cyclic grip.

SECTION 8: HANDLING AND MAINTENANCE

No change.

SECTION 10: SAFETY TIPS

The autopilot is intended to reduce pilot workload and enhance safety. It is important that pilots do not misuse this capability and allow their attention to be diverted. Pilots should continue monitoring the flight controls and helicopter attitude as well as looking for traffic and other obstacles. Autopilot disengagement requires immediate pilot attention. Pilots must always be prepared to take manual control.

The autopilot is not certified for flight in Instrument Meteorological Conditions (IMC). Adhering to appropriate VFR weather minimums is essential for safety.

If an inadvertent loss of outside visual reference occurs, the pilot must regain visual conditions as quickly as possible while avoiding abrupt, disorienting maneuvers. The following procedure is recommended:

1. If not already engaged, immediately engage autopilot SAS mode and allow autopilot to recover from unusual attitude if one has occurred.
2. Select a heading and altitude to ensure terrain and obstacle clearance. Turns and/or climbs may be required. Engage additional autopilot modes as desired for workload reduction.
3. While maintaining terrain and obstacle clearance, maneuver toward conditions of improved visibility.

INTENTIONALLY BLANK

PILOT KNOWLEDGE AND PROFICIENCY (cont'd)

- Flight planning (*Ref SNs 15, 26, and 43*)
 - Thorough preflight inspection
 - Fuel
 - Weather
 - Performance (hot/high/loading)
- Distractions (*Ref SNs 16, 34, 36, and 41*)
 - Failure to keep eyes outside scanning for wires, other obstacles, and traffic
 - High workload missions such as photo flights
 - Passengers
 - Avionics
 - Cell phones
- Low-G and mast bumping (*Ref SNs 11, 29, and 32*)
 - Avoidance
 - Reduce airspeed in turbulence
 - Monitor airspeed when lightly loaded
 - Ensure passenger controls are removed
 - Recognition and recovery

CAUTION

Never practice/demonstrate low-G in flight.
Low-G training should be knowledge based only.

- Low RPM considerations (*Ref SNs 10, 24, and 29*)
 - Recognition and recovery
- Power failures (*Ref SNs 10, 24, and 29*)
 - Instinctive autorotation entry
 - Continuously consider emergency landing sites throughout every flight
- Practice autorotations (*Ref SN 38*)
 - Proven, safe methods

CAUTION

In-flight practice of Low RPM, power failures, and autorotations should only be conducted under the supervision of an instructor.

- Carburetor ice (*Ref SNs 25 and 31*)
 - Conditions conducive
 - Use of carb heat
- Confined area operations (*Ref SN 22*)
 - High and low reconnaissance
 - Assessing wind
 - Power margins

SAFETY NOTICES

The following Safety Notices have been issued by Robinson Helicopter Company as a result of various accidents and incidents. Studying the mistakes made by other pilots will help you avoid making the same errors. Safety Notices are available on the RHC website: www.robinsonheli.com.

SAFETY NOTICE

TITLE

SN-1	Inadvertent Actuation of Mixture Control in Flight
SN-9	Many Accidents Involve Dynamic Rollover
SN-10	Fatal Accidents Caused by Low RPM Rotor Stall
SN-11	Low-G Pushovers - Extremely Dangerous
SN-13	Do Not Attach Items to the Skids
SN-15	Fuel Exhaustion Can Be Fatal
SN-16	Power Lines Are Deadly
SN-17	Never Exit Helicopter with Engine Running Hold Controls When Boarding Passengers Never Land in Tall Dry Grass
SN-18	Loss of Visibility Can Be Fatal Overconfidence Prevails in Accidents
SN-19	Flying Low Over Water is Very Hazardous
SN-20	Beware of Demonstration or Initial Training Flights
SN-22	Vortex Ring State Avoidance, Recognition, and Recovery
SN-23	Walking into Tail Rotor Can Be Fatal
SN-24	Low RPM Rotor Stall Can Be Fatal
SN-25	Carburetor Ice
SN-26	Night Flight Plus Bad Weather Can Be Deadly
SN-27	Surprise Throttle Chops Can Be Deadly
SN-28	Listen for Impending Bearing Failure Clutch Light Warning
SN-29	Airplane Pilots High Risk When Flying Helicopters
SN-30	Loose Objects Can Be Fatal
SN-31	Governor Can Mask Carb Ice
SN-32	High Winds or Turbulence
SN-33	Drive Belt Slack
SN-34	Aerial Survey and Photo Flights - Very High Risk
SN-35	Flying Near Broadcast Towers
SN-36	Overspeeds During Liftoff
SN-37	Exceeding Approved Limitations Can Be Fatal
SN-38	Practice Autorotations Cause Many Training Accidents
SN-39	Unusual Vibration Can Indicate a Main Rotor Blade Crack
SN-40	Post-Crash Fires
SN-41	Pilot Distractions
SN-42	Unanticipated Yaw
SN-43	Use Extra Caution During Post-Maintenance Flights
SN-44	Carrying Passengers

Safety Notice SN-22

Issued: July 1986 Revised: June 1994; October 2016, January 2024

VORTEX RING STATE AVOIDANCE, RECOGNITION, AND RECOVERY

A vertical descent or steep approach, particularly downwind, can cause the rotor to fly into its own downwash. At certain descent rates, large vortices develop as the downwash is recirculated through the rotor disk. This condition is known as vortex ring state (VRS). Once VRS exists, adding power (raising collective) can unexpectedly increase descent rate due to the increase in downwash recirculating through the rotor. Recovery can only be accomplished by moving the rotor disk out of its own downwash.

To avoid VRS, reduce rate of descent before reducing airspeed. A good rule to follow is never allow your airspeed to be less than 30 knots until your rate of descent is less than 300 feet per minute.

Signs that VRS is developing include increased vibration levels, decreased control authority ("mushy controls"), and a rapid increase in sink rate. Pilots should always be aware of wind conditions and plan descents to avoid VRS. Pilots should be particularly alert to the possibility of VRS during OGE hover operations or steep approaches.

A recovery should be initiated as soon as VRS is suspected. Early recognition and immediate recovery by moving the rotor out of its downwash is essential. Large control inputs are not necessary and should be avoided. After recovery, increasing collective and/or airspeed will help to avoid re-entering VRS.

Safety Notice SN-23

Issued: Jul 86 Rev: Jun 94

WALKING INTO TAIL ROTOR CAN BE FATAL

Non-pilot passengers have been killed by inadvertently walking into a rotating tail rotor. Every possible precaution must be taken by the pilot to prevent this tragic type of accident. The following rules should always be observed:

- 1) Never allow anyone to approach the helicopter unless they are escorted or have been properly instructed. If necessary, shut down and stop rotors before boarding passengers.
- 2) Always have strobe light flashing when rotors are turning.
- 3) Instruct passengers to establish and maintain eye contact with pilot when approaching helicopter. (This will force them to approach only from the nose or side, never the tail).
- 4) Instruct passengers to leave the helicopter in full view of the pilot and walk only around the nose, never the tail.
- 5) Be especially careful when landing off airports as unseen children or adults might approach the helicopter from the rear.