

R22-series Cabin Heater Upgrade Installation Kit Instructions

Applicable to helicopter S/N 4782 and prior equipped with cabin heater. Kit upgrades heater installation to scroll-air intake and includes A169-39 shroud assembly for use with A169-35 (O-320 engine) or A169-37 (O-360 engine) muffler (not included).

NOTE

Visit www.robinsonheli.com to verify kit instructions are current revision. Review instructions before installation; contact RHC Technical Support with questions. Verify kit contents match list; contact RHC Customer Service if parts are missing or damaged.

ITEM	PART NUMBER	KIT CONTENTS	QTY
1	KI-256Instr.	Kit Instructions	1
2	A169-39	Shroud Assembly (6-inch diameter).	1
3	A675-2	Cover	1
4	A676-1	Cover	1
5	A785-41	Hose	1
6	B158-6	Heat Shrink – Black, 3/8-inch diameter (1-foot length)	1
7	B204-4+	Rivet (Note: “+” in contents part number indicates 10-qty pack)	1
8	B277-28	Clamp	2
9	B373-1	Outlet	1
10	2633	Hole Plug	2
11	AN525-832R6	Screw	4
12	AN526C832R8	Screw	1
13	MS21919WDG36	Clamp	1
14	NAS620-5+	Washer (Note: “+” in contents part number indicates 20-qty pack)	1
15	MS21042L08	Nut	5
16	NAS9301B-4-02	Rivet	3
17	NAS9301B-4-03	Rivet	3
18	NAS1149FN816P+	Washer (Note: “+” in contents part number indicates 20-qty pack)	1

Consumables

Refer to R22 Maintenance Manual (MM) § 23-70 for approved materials list.

- B270-1 Sealant
- Ty-raps, various sizes

Special Tools

- Hand-held grinder
- Rotary file or drum sander
- Manually-operated pop riveting tool

Kit Instructions**WARNING**

Review appropriate Safety Data Sheet (SDS) when working in proximity to hazardous materials. Specific recommendations for use of personal protective equipment are located in the SDS.

1. Ensure battery switch is off. Pull HEATER 10-amp circuit breaker. Disconnect battery ground (negative) cable.
2. Remove the lower scroll per MM § 6.210 a).

NOTE

Parenthetic dash numbers, such as (-2690), indicate number marked on wiring.

3. Refer to Illustrated Parts Catalog (IPC) Figure 21-3. Remove and discard A785-8 heater hose, if not previously removed. Disconnect A643 blower electrical connector. Remove and discard blower assembly, A640-1 air inlet screen, A911-1 outside air scoop, A903-1 outside air inlet, and installing hardware. Slide 1.25-inch length B158-6 heat shrink over (-131) wire connector and apply heat. Verify connector is insulated and heat shrink is secure. Secure (-131) wire to airframe harness using appropriately-sized ty-raps as required. Cinch ty-raps until snug without over-tightening, and trim tips flush with heads. Verify security.
4. Install A676-1 cover on side skirt using AN525-832R6 screw, NAS1149FN816P washer, and MS21042L08 nut, 4 places.
5. Open circuit breaker panel. Disconnect wires from HEATER 10-amp circuit breaker and remove circuit breaker. Slide 1-inch length B158-6 heat shrink over each wire terminal (seperately) and apply heat. Verify terminal is insulated and heat shrink is secure. Secure wires to wire bundle using appropriately-sized ty-raps as required. Cinch ty-raps until snug without over-tightening, and trim tips flush with heads. Verify security.
6. Secure circuit breaker panel. Install 2633 plug in HEATER circuit breaker hole.
7. Refer to MM Figure 11-2. Disconnect wires from blower on/off switch. Remove and discard switch. Slide 1-inch length B158-6 heat shrink over each wire terminal (seperately) and apply heat. Verify terminal is insulated and heat shrink is secure. Secure wires to wire bundle using appropriately-sized ty-raps as required. Cinch ty-raps until snug without over-tightening, and trim tips flush with heads. Verify security. Install 2633 plug in heater switch hole.
8. Refer to IPC Figure 21-3. Remove A753-1 outlet box cover and insulation. Remove A625-1 outlet box. Clean residual sealant from outlet box and baggage compartment floor. Verify sealant around B019-3 valve assembly is intact.

Kit Instructions (continued)**CAUTION**

No air leaks are permitted in the heater system. Ensure B270-1 sealant is applied without gaps and is dry before installing A753-1 outlet box cover.

9. Refer to Figure 1. Position A675-2 cover between A625-1 outlet box and floor, aligning installation hole. Temporarily secure cover and box to floor. Match drill two remaining installation holes in box thru cover. Remove box and cover. Deburr holes and clean up debris. Apply a layer of B270-1 sealant on mating surface of cover and floor. Install cover and outlet box. Seal around cover & outlet box edge using B270-1 sealant, adding sealant at A522-4 cabin heat control cable, as required. Allow sealant to dry completely. Install A753-1 outlet box cover and insulation.
10. Refer to Figure 2. Position B373-1 outlet on lower scroll as shown. Mark outer edge of outlet and rivet holes onto scroll. Measure and mark a second line 0.60 inch inside of first line.
11. Drill a series of 0.170-inch (#18 drill size) diameter holes inboard of the 0.60-inch line; carefully remove the drilled piece from scroll. Clean edge using a hand grinder fitted with a rotary file or drum sander.

CAUTION

Do not remove material beyond the 0.60-inch marked line. Loss of rivet edge distance may result.

12. Position B373-1 outlet over newly formed hole, holding dimensions shown in Figure 2. Drill 0.128-inch (#30 drill size) diameter rivet holes in scroll using outlet as guide.
13. Apply a layer of B270-1 sealant on mating surface of B373-1 outlet lip, forming a gasket-like seal. Position outlet on scroll, aligning rivet holes. Install (3) NAS9301B-4-02 or -03 rivets and (3) NAS620-5 washers, with washers inside of scroll.

NOTE

Due to varying thicknesses of scroll, outlet, and paint, both NAS9301B-4-02 and NAS9301B-4-03 rivets are supplied in kit. Proper rivet length is determined by installer during installation.

14. Install A169-39 (heater) shroud assembly per MM § 11-21 B.
15. Install lower scroll per MM § 6.220 e); standard torque (2) AN3-41A bolts per MM § 23-32.
16. Refer to Figure 3. Install A785-41 hose to muffler shroud and B373-1 outlet using (2) B277-28 clamps.
17. Refer to R22 IPC Figure 33-9 or 33-11. Remove landing light retainer and landing lights to gain access to chin.
18. Refer to Figure 4. Layout and mark position on belly along helicopter centerline at 15.0 – 16.0 inches forward from aft edge of A475-3 retainer. Visually check for clearance in the belly at the position to be drilled. Drill 0.170-inch (#18 drill size) diameter hole using drill bit fitted with a drill stop. Clean up debris inside chin.

Kit Instructions (continued)

19. Position MS21919WDG36 clamp on A785-25 hose as shown in Figure 4. Secure clamp using (1) AN526C832R8 screw (head on belly-side), (1) NAS1149FN816P washer, and (1) MS21042L08 nut. Visually verify clearance of hose from any wire bundle and tail rotor controls.
20. Position landing lights retainer and secure with (4) B204-4 rivets. Install and secure landing lights.
21. Ensure battery switch is off. Install ground (negative) cable to battery terminal and install hardware. Special torque terminal bolt as noted on battery label and torque stripe per MM Figure 2-1.
22. Revise helicopter's Weight and Balance Record in R22 Pilot's Operating Handbook (POH) Section 6 to reflect this installation by incorporating the following data:

Remove:

Item	Weight	Long. Arm	Long. Moment	Lat. Arm	Lat. Moment
Cabin Heater Installation w/Blower	-13.25 lb	109.68 in.	-1453.25 in.-lb	-2.28 in.	30.15 in.-lb

Install:

Item	Weight	Long. Arm	Long. Moment	Lat. Arm	Lat. Moment
KI-256 Cabin Heater Upgrade Installation	+11.0 lb	112.6 in.	1238.6 in.-lb	0.35 in.	3.85 in.-lb

23. Make appropriate maintenance record entries.

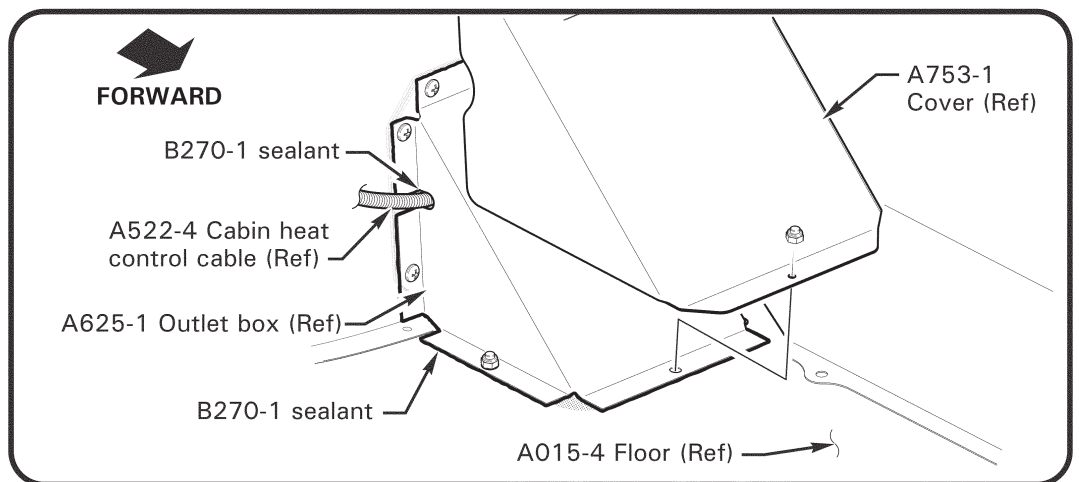
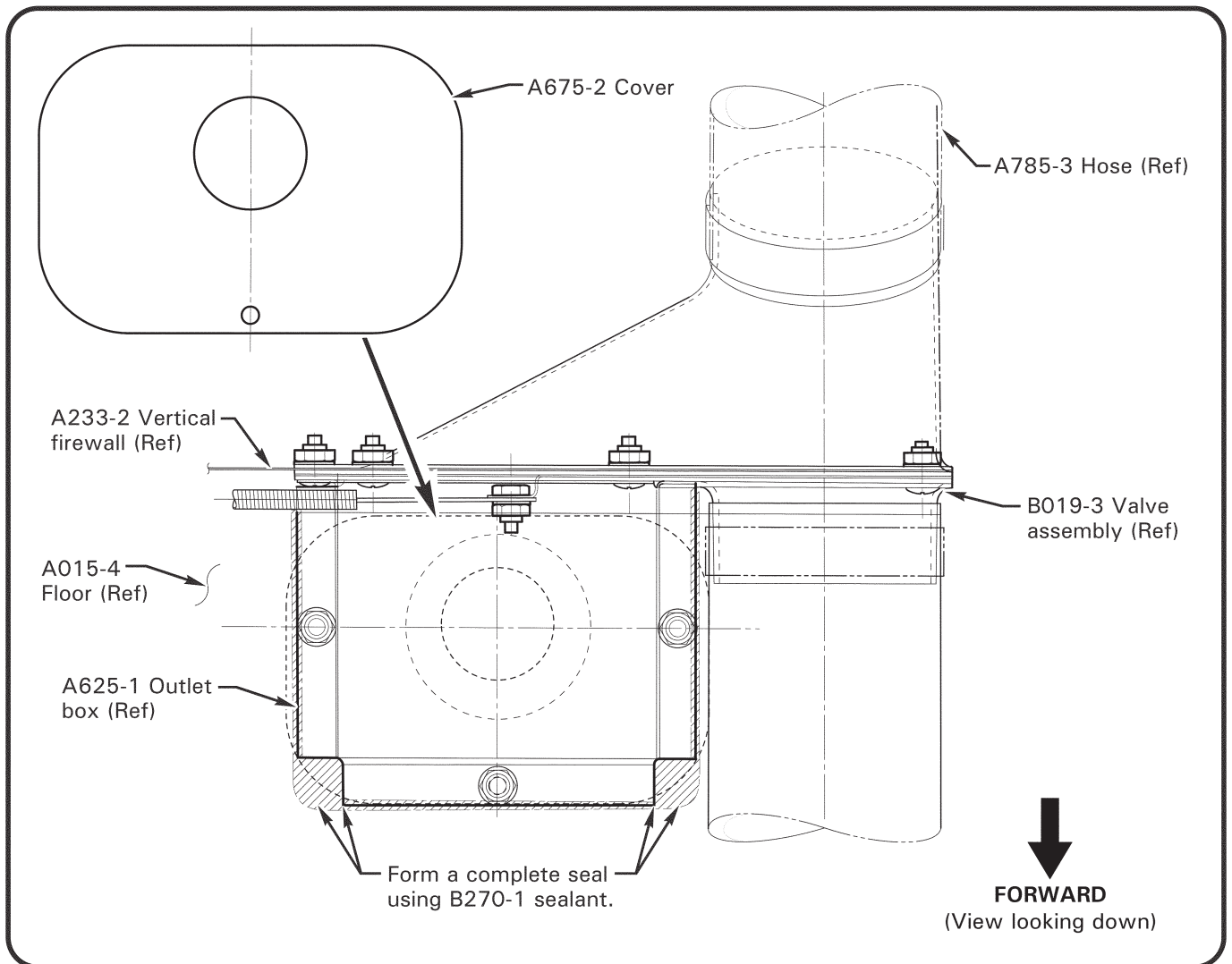

FIGURE 1

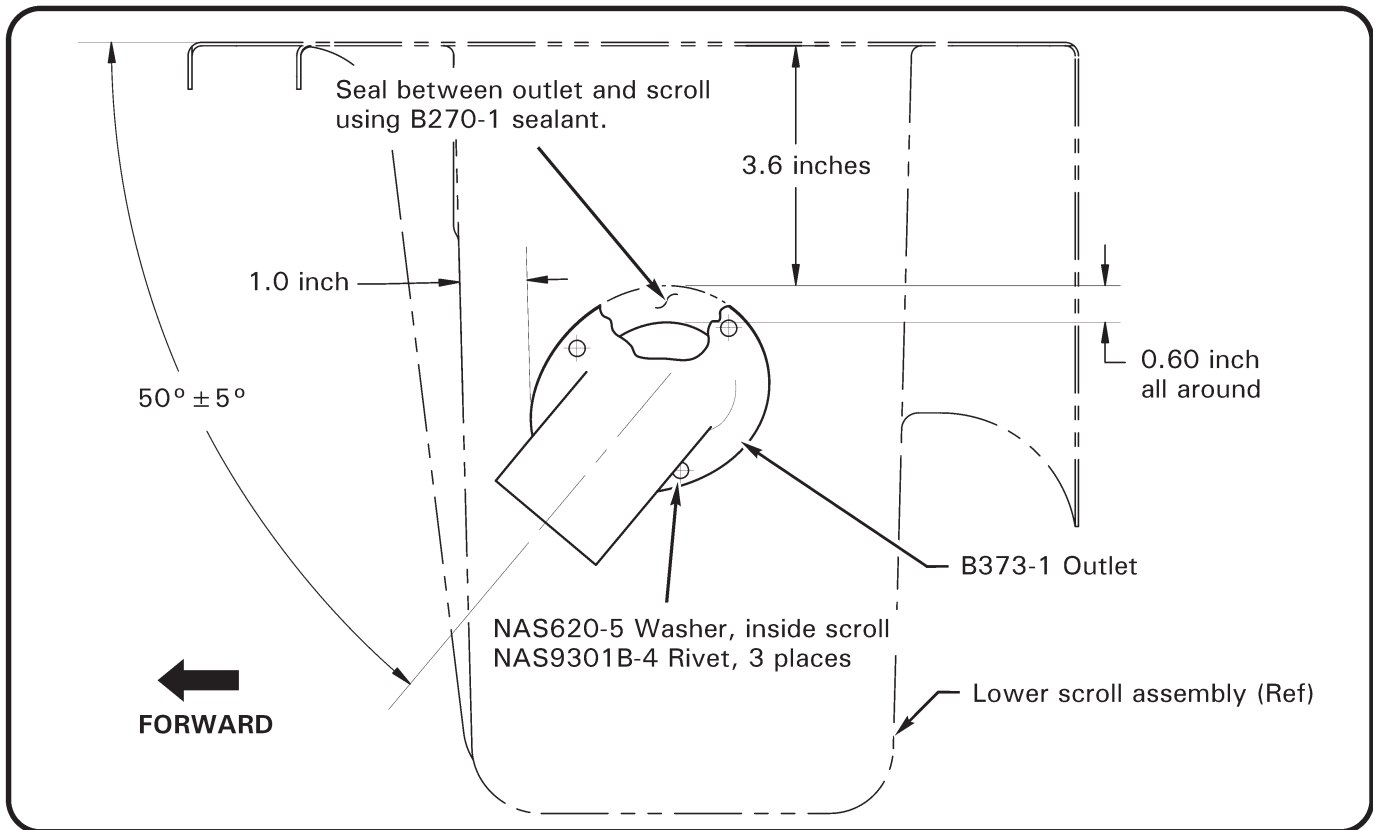

FIGURE 2

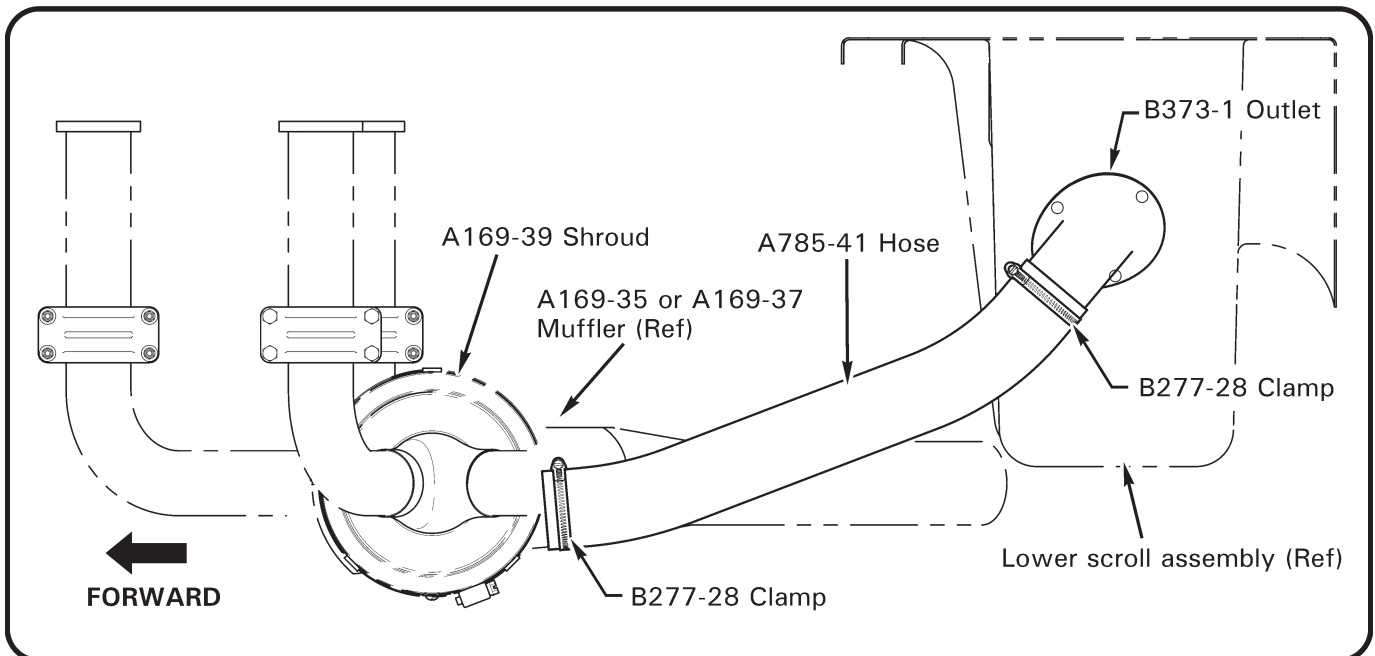

FIGURE 3

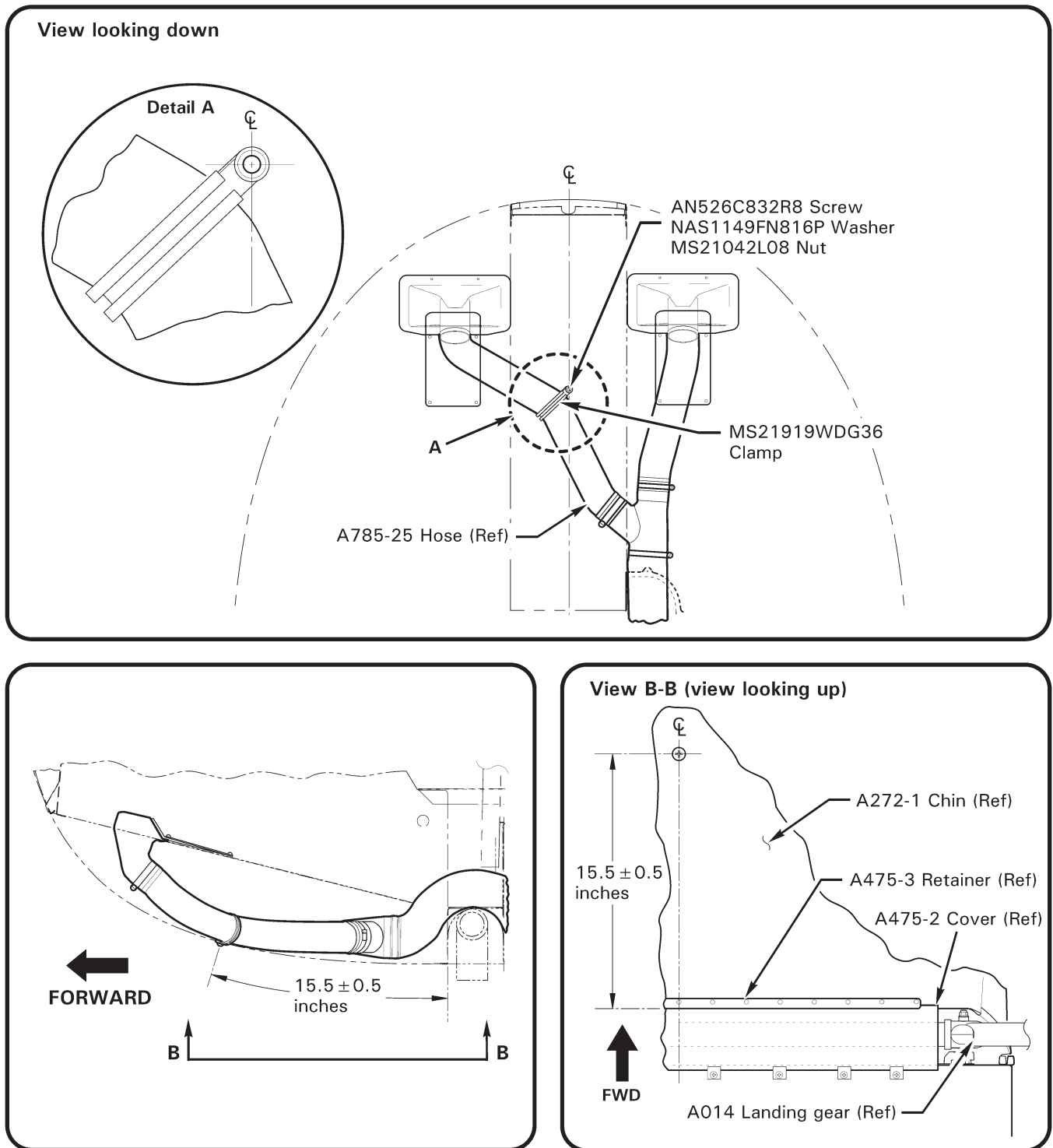

FIGURE 4