

CHAPTER 5
LANDING GEAR

<u>Section</u>	<u>Title</u>	<u>Page</u>
5.000	Landing Gear	5.1
5.001	Introduction	5.1
5.002	Description	5.1
5.100	Landing Gear Assembly	5.1
5.110	Landing Gear Removal	5.1
5.120	Landing Gear Installation	5.5
5.200	Cross Tubes	5.5
5.210	Cross Tube Removal	5.5
5.220	Cross Tube Installation	5.6
5.300	Skid Tubes	5.6
5.310	Skid Tube Removal	5.6
5.320	Skid Tube Installation	5.6
5.330	Skid Shoe Replacement	5.6
5.340	Ground Handling Wheel Support Replacement	5.7
5.350	Skid Extension Replacement	5.7
5.400	Strut Fairings	5.7
5.410	Strut Fairing Removal	5.7
5.420	Strut Fairing Installation	5.8
5.500	Utility Float Landing Gear	5.9
5.510	Utility Float Landing Gear Removal	5.9
5.520	Utility Float Landing Gear Installation	5.11
5.530	Utility Float Tube Removal	5.11
5.540	Utility Float Tube Installation	5.11
5.600	Emergency Pop-Out Float Landing Gear	5.12
5.610	Pop-Out Float Removal	5.12
5.620	Pop-Out Float Installation	5.13
5.630	Leak Check	5.15
5.640	Emergency Inflation Test	5.16
5.650	Pop-Out Float Packing Procedure	5.18

CHAPTER 5

LANDING GEAR (Continued)

<u>Section</u>	<u>Title</u>	<u>Page</u>
5.660	Pressure Cylinder Removal	5.21
5.665	Filling Pressure Cylinder	5.22
5.670	Pressure Cylinder Installation	5.24
5.680	Inflation Lever Rigging	5.27
5.690	Inflation Lever Shear-Rivet Replacement	5.27
5.700	Maintenance	5.29

CHAPTER 5
LANDING GEAR

5.000 Landing Gear

5.001 Introduction

This section covers the removal and installation of the landing gear assembly, cross tubes, skid tubes, skid shoes, ground handling wheel supports, and strut fairings.

5.002 Description

Standard landing gear consists of two aluminum skid tubes, four steel struts with forged aluminum elbows, and two aluminum cross tubes. The landing gear connects to the fuselage at each elbow. Aerodynamic fairings are clamped to each strut. The right forward connection is to a pivoting shackle which allows the forward cross tube to flex. The right, aft connection is to a flexible steel tube frame which allows the aft cross tube to flex. Skid shoes, constructed of 4130 steel with a hard wear surface, protect the underside of the skid tubes during landing.

R44 Clippers have permanently inflated utility floats or emergency pop-out floats mounted to skid tubes and incorporate extended steel struts and aft skid extensions to support the floats. Strut fairings are not installed with utility floats.

5.100 Landing Gear Assembly

5.110 Landing Gear Removal

1. Remove C388 channels and C475 cover at forward cross tube.
2. Remove D040 aft engine cowling and D041 engine belly cowling.
3. Disconnect A936 ground wire at aft, right elbow.
4. Hoist helicopter by main rotor hub per Section 1.220 until skids clear ground by approximately 4 inches.
5. Remove four NAS6607 landing gear mounting bolts. Remove forward, left mounting bolt first. Then rotate forward, right shackle to align mounting bolt with access hole in bulkhead before removing bolt. Forward bolts can be accessed from inside aft baggage compartments and through access holes under carpet at aft outboard corners of aft floor.

LANDING GEAR INSTALLATION

<u>Item</u>	<u>Part Number</u>	<u>Description</u>
1	A214-10	Washer
2	C014-10	Strut Assembly (fwd)
3	C105-1	Journal
4	LJS-1016	Bearing
5	C014-5	Shackle Assembly
6	C141-5	Washer
7	AN960-716L	Washer
8	D310-5	Aft Cowl Bracket, LH (shown)
	D310-6	Aft Cowl Bracket, RH (not shown)
9	B330-21	Palnut
10	NAS679A7	Nut
11	AN960-716	Washer
12	C278-1	Spacer
13	C241-1	Cross Tube (rear)
14	C014-9	Strut Assembly (rear)
15	C241-2	Cross Tube (fwd)
16	C141-6	Washer
17	C294-2	Bearing Assembly
18	C141-4	Washer
19	NAS6607-53	Bolt
20	A141-11	Washer
21	NAS6604-17	Bolt
22	C014-7	Support Assembly
23	C240-1	Elbow
24	NAS1291-4	Nut
25	C247-2	Rain Cap
26	NAS6604-41	Bolt
27	AN960-416L	Washer
28	A31007	Nut
29	S14119	Screw

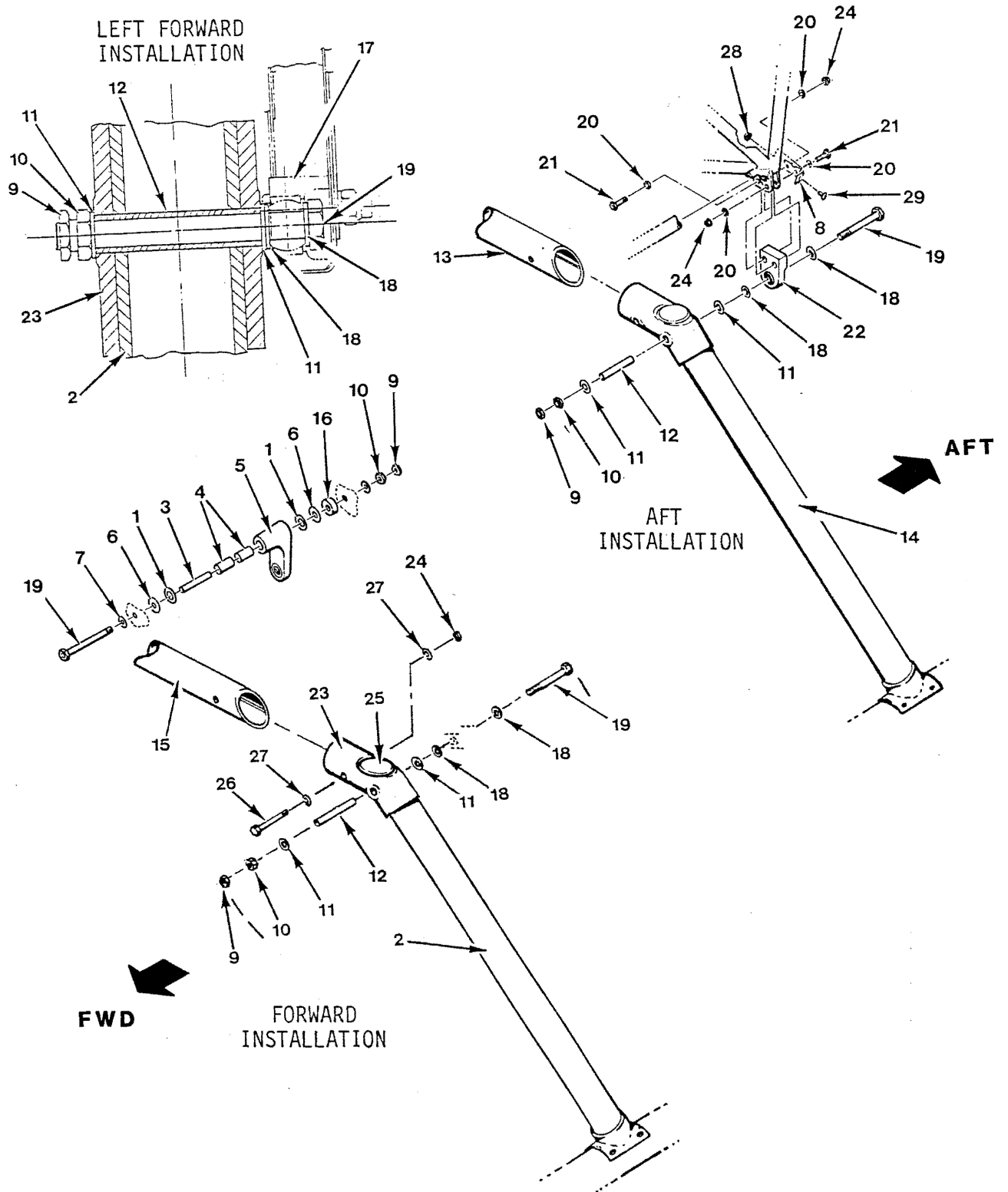

FIGURE 5-1 LANDING GEAR INSTALLATION

This page intentionally left blank.

5.120 Landing Gear Installation

- a) Hoist the helicopter per Section 1.
- b) Lift the right side of the landing gear and install both right side mounting bolts per Figure 5-1. Torque per Section 1.320, install palnuts, and torque stripe. Repeat on left side.
- c) Connect ground wire at right aft elbow and attach battery drain tube to aft cross tube.
- d) Install the C475-2 cover and the C388-1 channels at the forward cross tube.
- e) Install all cowling.

5.200 CROSS TUBES

5.210 Cross Tube Removal

The aft cross tube must be replaced if it has yielded so that the tail skid is less than 30 inches from the ground.

NOTE

For hard landing inspection, see Section 2.550.

- a) Remove landing gear per Section 5.110.
- b) Disconnect one of the struts from the skid tube.
- c) Remove the bolts in the elbows at each end of the cross tube and tap the elbows off of the cross tube.

5.220 Cross Tube Installation

- a) Install cross tube into the elbows and install bolts per Figure 5-1. Torque bolts per Section 1.320.
- b) Connect the unbolted strut to the skid tube and torque the NAS6606-4 bolts per Section 1.320.
- c) Install landing gear per Section 5.120.

5.300 SKID TUBES

5.310 Skid Tube Removal

- a) Raise one side of the helicopter by jacking under one end of the aft cross tube, one inch inboard of the elbow.
- b) Remove the 4 bolts at each landing gear strut. Remove the skid tube.
- c) Remove the C937 skid extension by removing the aft skid shoe. Remove the C719-1 wheel support.

5.320 Skid Tube Installation

- a) Install the C937 skid extension and aft skid shoe onto the C014-11 or -12 skid tube assembly. Install the C719-1 wheel support and torque per Section 1.330; the reduced torque required by Section 1.330 is required to avoid damaging the skid tube.
- b) Place the skid tube assembly under the fore and aft gear struts and install the attach bolts. Torque the NAS6606-4 attach bolts per Section 1.320.
- c) Seal the slot in the side of the skid extension with B270-9 adhesive, if required.

5.330 Skid Shoe Replacement

The two A667-8 forward skid shoes and seven A667-7 skid shoes (four on the left skid and three on the right) are fastened with A142-1 screws. Use new screws when replacing shoes and torque to 27 in.-lb. Skid shoes must be replaced when the bottoms have worn to 0.050 inch thick at their thinnest point.

- a) To inspect or replace the aft shoe on each skid, install ground handling wheels to lift the helicopter or jack up the helicopter at the aft landing gear cross tube per Figure 5-3B. Remove and discard worn skid shoes and screws and replace.
- b) To inspect or replace all other skid shoes, install ground handling wheels, pull the tail down and place wood blocks under the skids to hold the skids up per Figure 5-3A. Replace any worn shoes.

5.340 Ground Handling Wheel Support Replacement

- a) Remove the two mounting bolts and remove the C719-1 support.
- b) Install the support using NAS6604-47 bolts and torque per Section 1.330. The reduced torque of Section 1.330 is required to avoid damaging the skid tube.

5.350 Skid Extension Replacement

- a) Raise one side of the helicopter by jacking under one end of the aft cross tube, one inch inboard of the elbow.
- b) Remove the aft skid shoe and remove the four bolts attaching the aft strut to the skid tube.
- c) Remove the C937-1 or -2 skid tube extension and replace.
- d) Attach the strut to the skid tube and torque the four NAS6606-4 bolts per Section 1.320. Install the skid shoe.
- e) Seal the slot in the side of the skid extension with B270-9 adhesive.

5.400 STRUT FAIRINGS

5.410 Strut Fairing Removal

- a) Loosen the clamps through the access hole on the inboard side of the fairing.
- b) Remove all screws along the trailing edge.
- c) Unscrew the clamps and slide the fairing off of the strut.

5.420 Strut Fairing Installation

- a) Verify that a B162-3 clip nut is installed at each hole at the trailing edge of the fairing and that the strut clamps pass through both of the clips riveted to the fairing.
- b) Slide the fairing onto the strut and loosely fasten the two clamps.
- c) Install and tighten all screws along the trailing edge.
- d) Position fairings by placing a long straight edge across both forward and aft fairings at the lower clamps (See below). The distance from the straight edge to the centerline of the trailing edge should measure 1.4 inches. Check for 0.10 inch clearance all around both ends of the fairing. Remove fairing to trim and reinstall, if required.
- e) Apply B270-10 adhesive to both clamp threads and torque per Section 1.330. Verify 1.4 inch dimension with the straight edge.

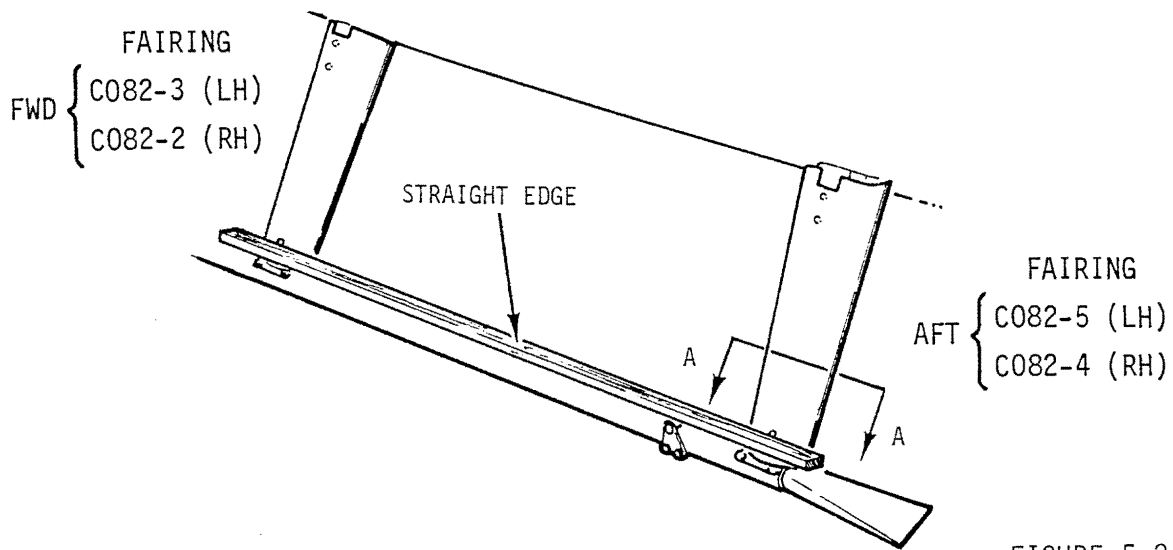
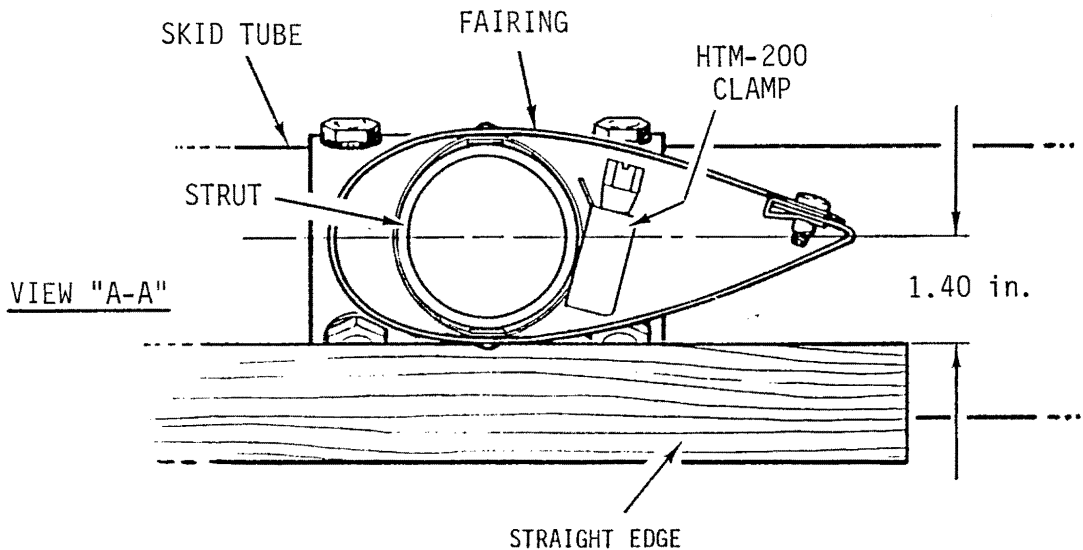

FIGURE 5-2



5.500 UTILITY FLOAT LANDING GEAR

The Robinson R44 Clipper helicopter may be flown with float landing gear or standard landing gear installed. When changing configurations, remove complete utility float landing gear and install complete standard landing gear. Do not remove float tubes from landing gear skid tubes unless necessary for repairs.

CAUTION

Float landing gear can only be installed on R44 Clipper helicopters.

5.510 Utility Float Landing Gear Removal

1. Remove float landing gear per Section 5.110.
2. Install standard landing gear per Section 5.120.
3. Remove C050 float stabilizer per Section 4.326.
4. Remove D372-2 air dams aft of static ports. Reinstall attaching screws.
5. Revise Equipment List/Weight and Balance data (located in helicopter Pilot's Operating Handbook, Section 6) using following information:

Part Number	Description	Weight (lb)	CG Arm (in.)	Moment (in.-lb)
C034-2	Utility Float Landing Gear	104.3	95.2	9929
C050-2	Utility Float Stabilizer	1.1	335.4	369
C014-8	Standard Landing Gear	60.9	86.3	5256

6. Perform flight check per Section 2.220.
7. Check and adjust autorotation RPM per Section 10.250 (usually requires lengthening pitch links approximately 1 full turn at upper rod end).

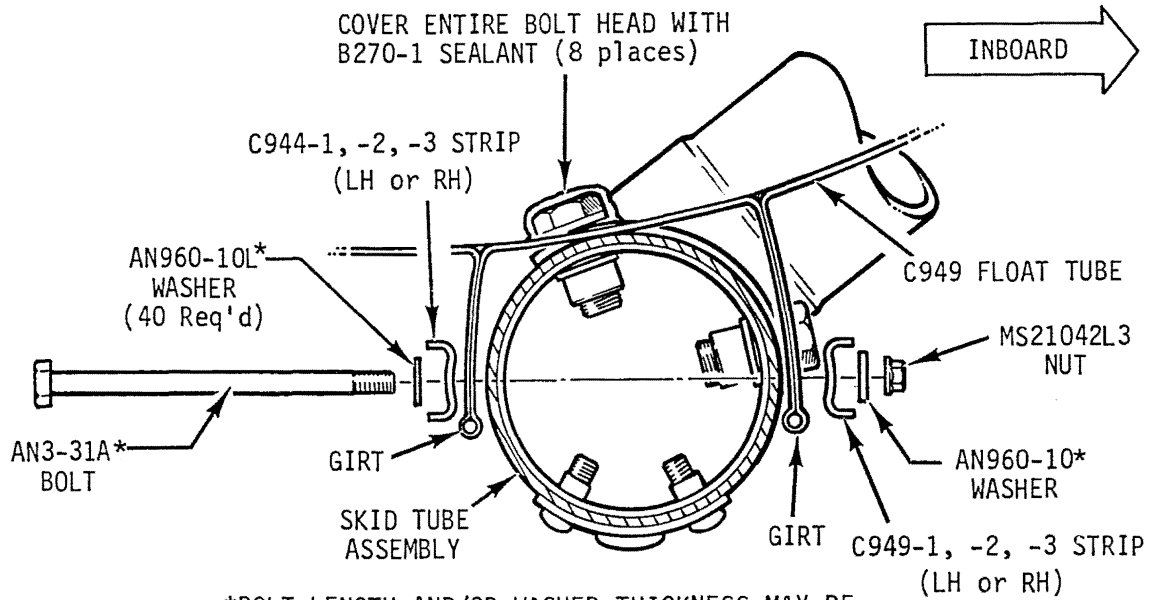

*BOLT LENGTH AND/OR WASHER THICKNESS MAY BE VARIED AS REQUIRED TO MAINTAIN 2-4 THREADS SHOWING BEYOND NUTS. SEAL UNDER HEAD AND NUT AND AROUND BOLT BETWEEN GIRTS AND SKID TUBE WITH B270-1 SEALANT.

FIGURE 5-3 UTILITY FLOAT ATTACHMENT
(LEFT SIDE SHOWN, VIEW LOOKING FORWARD)

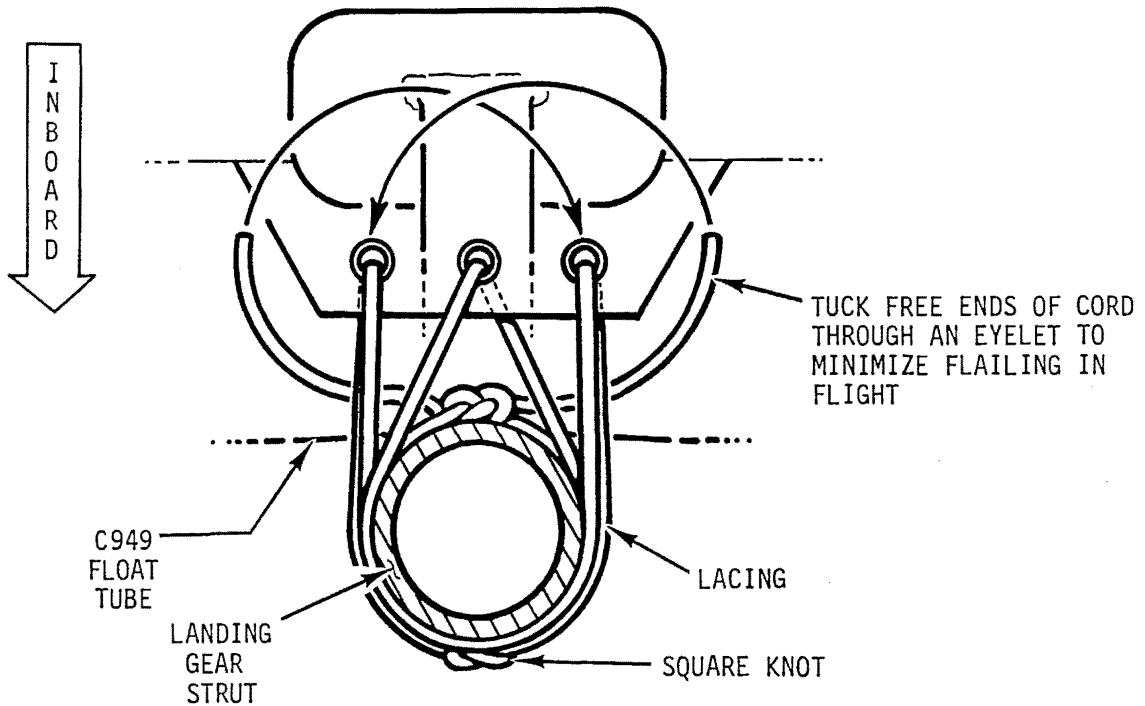

FIGURE 5-4 UTILITY FLOAT-TO-STRUT ATTACHMENT
(VIEW LOOKING DOWN)

5.520 Utility Float Landing Gear Installation

1. Remove standard landing gear per Section 5.110.
2. Install utility float landing gear per Section 5.120.
3. Install C050 float stabilizer per Section 4.327.
4. Adjust float pressure per helicopter's Pilot's Operating Handbook.
5. Install D372-2 air dams aft of static ports using existing screws.
6. Revise Equipment List/Weight and Balance data (located in helicopter's Pilot's Operating Handbook Section 6) using data provided in Section 5.510.
7. Shorten both main rotor pitch links by one full turn of upper rod end.
8. Perform flight check per Section 2.230.
9. Check and adjust autorotation RPM per Section 10.250.

5.530 Utility Float Tube Removal

1. Deflate float to loosen lacings.
2. Untie and remove lacings at each landing gear strut.
3. Remove hardware attaching float tube to skid tube and skid extension.
4. Remove retainer strips from girts. Carefully separate girt from skid tube and skid extension.

NOTE

Sealant between girt and skid tube at each bolt hole also acts as an adhesive. Use caution to avoid girt damage during removal.

5.540 Utility Float Tube Installation

NOTE

Before installation, remove old sealant from skid, float, girts, and hardware. A soft plastic scraper may be used.

1. See Figure 5-3. Ensure bolt heads directly beneath float are covered with a protective layer of B270-1 sealant (see Section 1.480). Apply additional sealant as required.
2. See Figure 5-3. Position uninflated float tube over landing gear skid tube and extension. Align holes in C944 retainer strips, float tube girts, and skid tube.
3. Install AN3 attach bolts per Figure 5-3. Seal under bolt head and nut with B270-1 sealant (ref Section 1.480). Torque bolts per Section 1.320.

5.540 Utility Float Tube Installation (cont'd)

4. Inflate float with filtered, oil-free, dry air to pressure specified in Pilot's Operating Handbook.
5. Install and tighten lacing at each landing gear strut per Figure 5-4.

5.600 EMERGENCY POP-OUT FLOAT LANDING GEAR

Emergency pop-out floats are an option for R44 Clippers and replace permanently inflated utility floats. Included are extended struts, skid extensions, uninflated floats stowed in protective covers along skid tubes, a lightweight composite pressure cylinder located in the compartment under the left-front seat, an inflation manifold, an inflation lever located on the pilot's collective, and an additional horizontal stabilizer at base of lower vertical stabilizer. A valve atop the pressure cylinder incorporates a pressure gage, a thermal relief valve which releases pressure if exposed to excessive heat (281 degrees F), a metal sealing disk, and a spring-loaded pin. To inflate the floats, the red inflation lever on pilot's collective stick must first have its spring-loaded safety in the READY position and then the lever must be squeezed forcefully enough to shear an aluminum rivet. Squeezing the lever causes a spring-loaded pin to puncture the metal sealing disk and allows the 4945 psig (nominal, at 20°C) helium charge to inflate both floats via the manifold. The manifold consists of hoses with metal fittings incorporating a check valve at each float chamber. There are six chambers per float (earlier versions have five chambers). Each float chamber also has a topping valve for manual inflation and a pressure relief valve which vents excessive internal pressure. When inflated, pop-out floats are identical to utility floats in size, shape, and internal chamber arrangement.

If installing utility float or standard landing gear in place of pop-out floats, removal of pressure cylinder, inflation lever (including brackets and cable), and exterior hoses (cap pressure cylinder hose and T-fitting in forward cross tube tunnel) is required. Additionally, check autorotation RPM per Section 10.250 and update empty weight and balance.

WARNING

Cylinder contents are under extreme pressure. Install locking pin in pressure cylinder valve (see Figure 5-6) when working in forward left baggage compartment, during cylinder removal or installation, and when working on floats or inflation hoses. REMOVE LOCKING PIN WHEN WORK IS COMPLETED.

5.610 Pop-out Float Removal**NOTE**

To help prevent float damage, avoid removing floats from skid tubes unless necessary for repairs.

1. Remove heat-shrink and disconnect flexible line exiting forward strut fairing from T-fitting on float. Cap line and T-fitting to prevent contamination.

5.610 Pop-out Float Removal (cont'd)

2. Unfasten hook-and-loop fasteners along inboard sections of float cover to expose lacing. Loosen, but do not remove, lacing.
3. See Figure 5-5. Remove AN3 bolts attaching float to skid tube and skid extension.
4. See Figure 5-5. Remove C944 retainer strips from girts. Carefully separate girts from skid tube and skid extension.

NOTE

Sealant installed between girts and skid tube at each bolt hole also acts as an adhesive. Use caution to avoid girt damage during removal.

5.620 Pop-out Float Installation

NOTE

Before installation, remove old sealant from skids, floats, and hardware. A soft plastic scraper may be used.

WARNING

Cylinder contents are under extreme pressure. Install locking pin in pressure cylinder valve (see Figure 5-6) when working in forward left baggage compartment, during cylinder removal or installation, and when working on pop-out floats or inflation hoses. **Remove locking pin when work is completed.**

1. See Figure 5-5. Ensure strut bolt heads directly beneath float are covered with a protective layer of B270-1 sealant (see Section 1.480). Apply additional sealant as required.
2. See Figure 5-5. Position uninflated float over landing gear skid tube and skid extension. Align holes in C944 retainer strips, float cover, float girts, and skid.
3. Install AN3 attach bolts per Figure 5-5. Seal under bolt head, nut, and around bolt between girts and skid tube with B270-1 sealant (see Section 1.480). Torque bolts per Section 1.320.
4. Inflate float with filtered, oil-free, dry air to 3.0 psig via topping valves.
5. Slide heat-shrink over flexible line exiting forward strut fairing. Ensure heat-shrink is of sufficient length to cover all sharp edges and seal out water after activation. Remove protective caps and connect flexible line to float T-fitting. Orient connection as required to minimize preload. Torque fitting per Section 1.330. Position heat-shrink over fittings and shrink with heat gun, using a shield to protect float from heat.
6. Pack floats per Section 5.650.

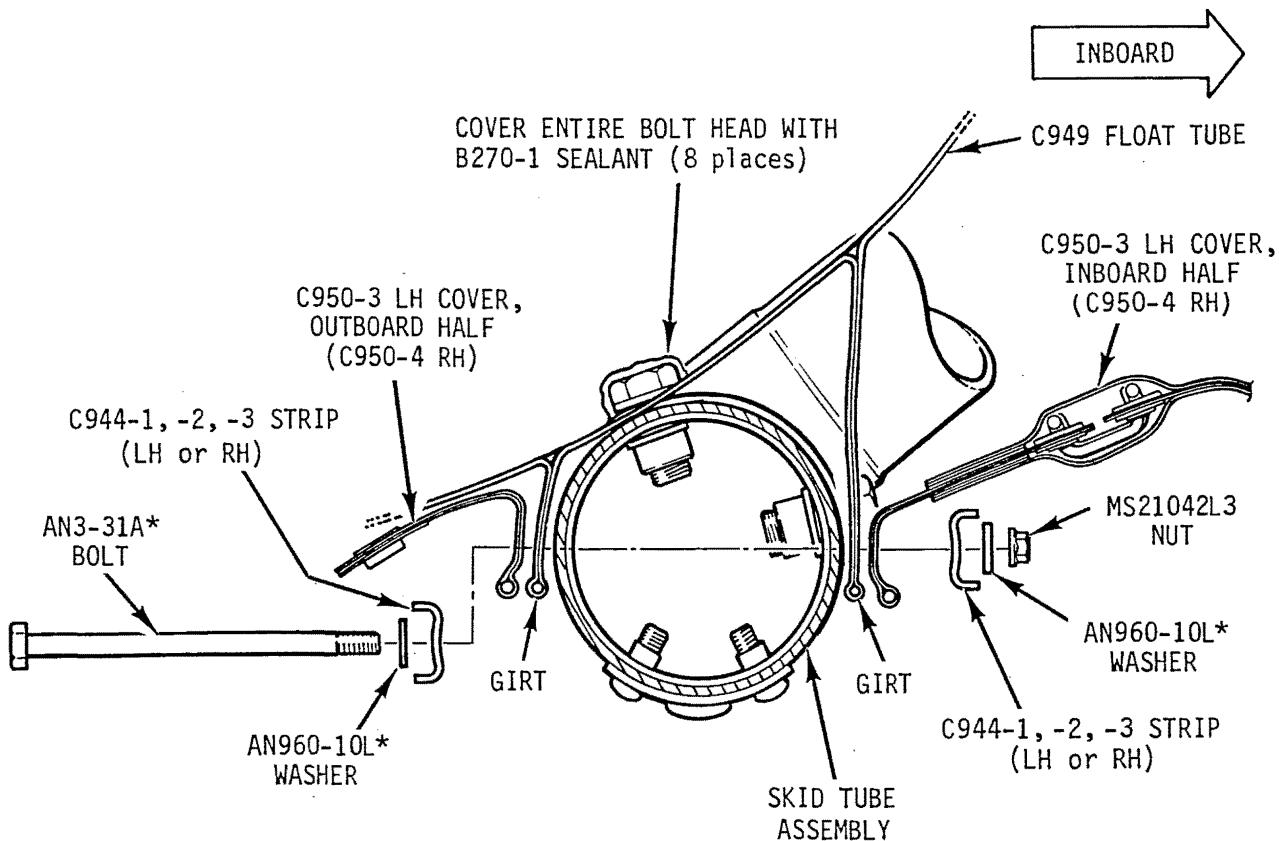

*BOLT LENGTH AND/OR WASHER THICKNESS MAY BE VARIED AS REQUIRED TO MAINTAIN 2-4 THREADS SHOWING BEYOND NUTS. SEAL UNDER HEAD AND NUT AND AROUND BOLT BETWEEN GIRTS AND SKID TUBE WITH B270-1 SEALANT.

FIGURE 5-5 POP-OUT FLOAT ATTACHMENT
(LEFT SIDE SHOWN, VIEW LOOKING FORWARD)

5.630 Leak Check**WARNING**

Cylinder contents are under extreme pressure. Install locking pin in pressure cylinder valve (see Figure 5-6) when working in forward left baggage compartment, during cylinder removal or installation, and when working on pop-out floats or inflation hoses. **Remove locking pin when work is completed.**

1. Disconnect D674-1 line assembly from pressure cylinder valve. Install protective cap on cylinder valve fitting. Cover D674-1 line fitting to prevent contamination, but do not install an air-tight seal (D674-1 line must be allowed to leak to verify check valve function at each float chamber).
2. Unfasten hook-and-loop fasteners along inboard sections of float cover to expose lacing. Loosen, but do not remove, lacing.
3. Unfasten outboard sections of float cover and unroll float to expose valves.
4. Inflate floats with filtered, oil-free, dry air to 2.0 psig via topping valves.
5. Allow float air temperature to stabilize for 5 minutes minimum then record OAT and pressure in each float chamber.
6. One to two hours after initial pressure check, again record OAT and pressure in each float chamber. Allowable chamber pressure drop from initial measurement is 0.2 psig adjusted for any temperature change. Pressure will change by 0.06 psig per degree C temperature change. For example, float chamber pressure will decrease 0.6 psig if temperature drops 10 degrees C.
7. If leaks are detected, repair float with supplied repair kit and repeat steps 4, 5, & 6.
8. Connect D674-1 line assembly to cylinder valve and torque per Section 1.330.
9. Pack floats per Section 5.650.

NOTE

Annually apply A257-7 dry-film lubricant (see Section 1.470) to float cover snap mating surfaces.

5.640 Emergency Inflation Test

WARNING

Cylinder contents are under extreme pressure. Install locking pin in pressure cylinder valve (see Figure 5-6) when working in forward left baggage compartment, during cylinder removal or installation, and when working on pop-out floats or inflation hoses. **Remove locking pin when work is completed.**

1. Unsnap outboard edge of both float covers. Hook-and-loop fasteners (inboard) may remain secured.
2. Remove locking pin from valve, move inflation lever safety to READY position, and verify area around floats is clear.
3. Squeeze inflation lever to inflate floats. Approximately 20 pounds force will be required due to the shear-riquet. Time for floats to attain full shape without wrinkles should be three seconds or less.

CAUTION

Floats inflate rapidly and with a loud noise. Keep area clear during inflation and inform all nearby personnel. Remove or close all doors prior to inflation. Open doors interfere with float inflation and may be damaged.

4. Allow float temperatures to stabilize for at least five minutes then record OAT and pressure in each float chamber. Minimum allowable pressures are:

O.A.T (degrees C)	Minimum Pressure (psig) in Forward Two Chambers	Minimum Pressure (psig) in Middle Chamber	Minimum Pressure (psig) in Aft Two Chambers
5-9	1.30	1.00	0.60
10-14	1.60	1.30	0.90
15-19	1.90	1.60	1.20
20-24	2.20	1.90	1.50
25-29	2.50	2.20	1.80
30-34	2.80	2.50	2.10
35-39	3.10	2.80	2.40

5.640 Emergency Inflation Test (continued)

5. Disconnect D674-1 hose assembly from pressure cylinder valve immediately after initial pressure check. Install protective cap on cylinder valve fitting. Cover D674-1 hose fitting to prevent contamination, but do not install an air tight seal (D674-1 hose must be allowed to leak to verify check valve function at each float chamber).
6. Verify no rips or chafing on floats or covers.
7. One to two hours after initial pressure check, again record OAT and pressure in each float chamber. Allowable chamber pressure drop from initial measurement is 0.20 psi adjusted for any temperature change. Pressure will change by 0.06 psi per degree C temperature change. For example, float chamber pressure will decrease 0.6 psig if temperature drops 10 degrees C.
8. If leaks are detected, repair float with supplied repair kit then perform leak check per § 5.630 on repaired float chamber.
9. Connect D674-1 hose assembly to valve fitting. Orient line as required to maintain minimum 0.25 inch clearance to cylinder and C390-5 panel. Torque B-nut per § 23-33 and torque stripe.
10. Pack floats per § 5.650.

NOTE

Annually apply A257-7 dry-film lubricant (see § 23-78) to float cover snap mating surfaces.

11. Remove D679 pressure cylinder assembly per § 5.660 and return to RHC for servicing.
12. Install serviceable pressure cylinder per § 5.670.
13. Rig inflation lever per § 5.690.
14. Replace inflation lever shear rivet per § 5.680.

5.650 Pop-out Float Packing Procedure

1. With float inflated, verify tees are oriented to minimize preload on hoses. Deflate float. Verify float is properly secured to skid and all hoses are properly connected and covered with heat shrink.
2. Spread deflated float to outboard side of skid tube. Using a vacuum, evacuate each float chamber through topping valve to remove as much air as possible.
3. Using a cloth covered with talcum powder, lightly coat entire float, including inside of covers.

4. Fold front end of float under and back until fold line reaches girt:

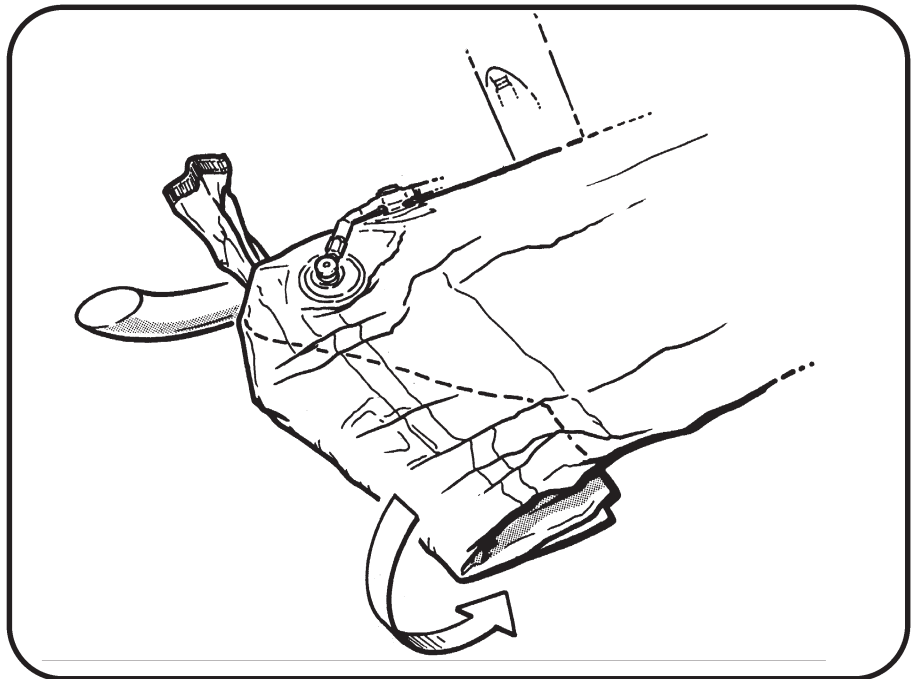

5. Fold aft end of float over and forward until fold line reaches girt:

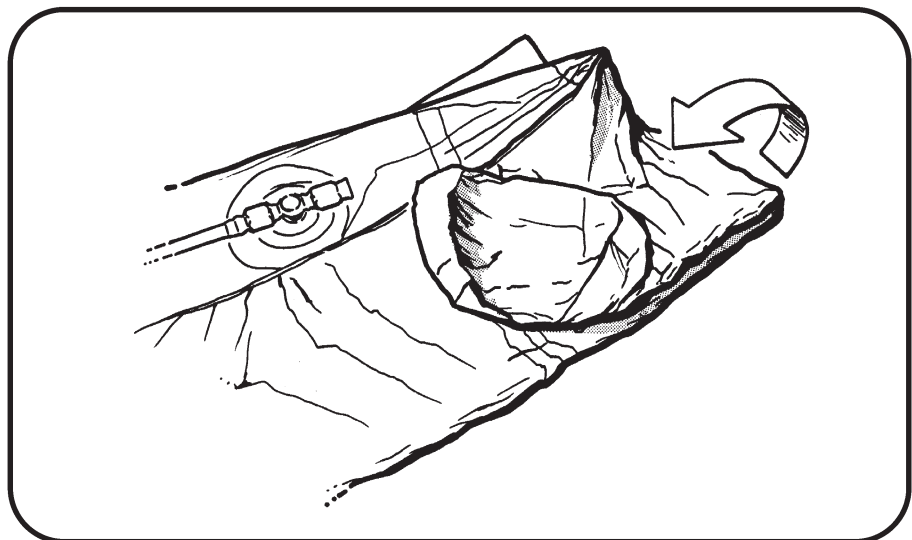

5.650 Pop-out Float Packing Procedure (cont'd)

6. Secure hook-and-loop fasteners at inside of inboard girt along length of cover:

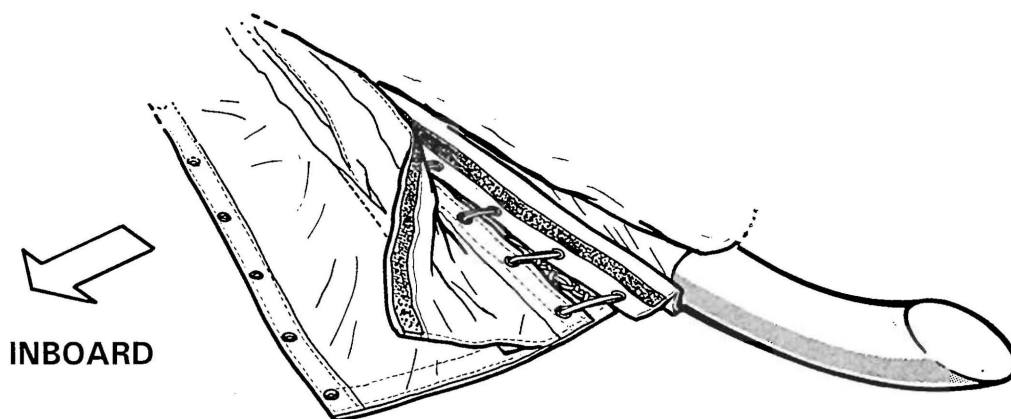

7. Align hoses and valve cover flaps and roll float from outer edge toward skid as tightly as possible:

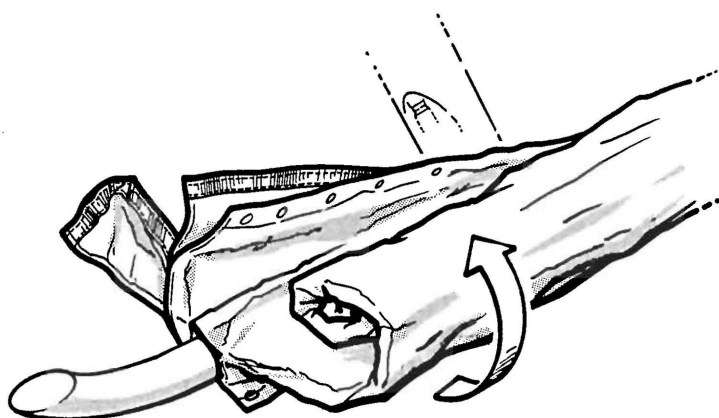

5.650 Pop-out Float Packing Procedure (cont'd)

8. Hold float on top of skid tube and install cover around float. Using a swab or small brush, apply A257-7 lubricant to mating surfaces of snaps. Secure hook-and-loop and snap fasteners along outboard girt (see Figure 5-5).
9. There are two lacing cords per float. One cord secures the float cover on the skid aft extension. The remaining cord secures the float cover to the skid. Verify lacing cord installed through grommets in cover using crossover ("ladder" lacing) method shown below:

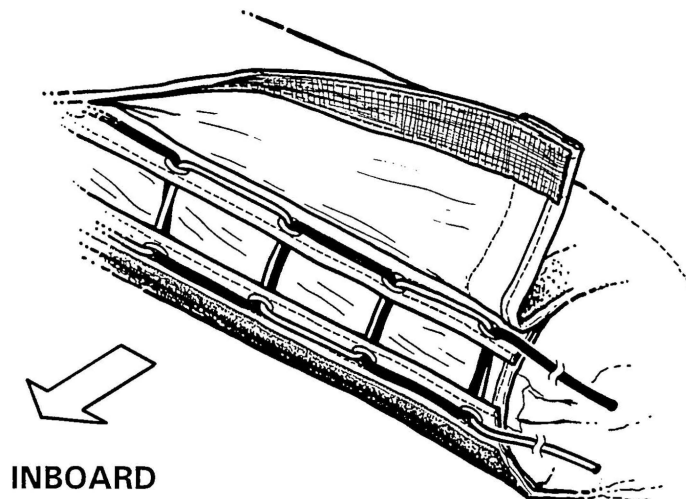

10. Pull lacing at each segment until tight or until material edges join; do not overtighten. Tie lacing ends in double square knots (4 alternating overhand knots) to secure.
11. Tuck in loose ends of lacing cord as shown and secure hook-and-loop fasteners along length of cover. Secure hook-and-loop fasteners at end caps:

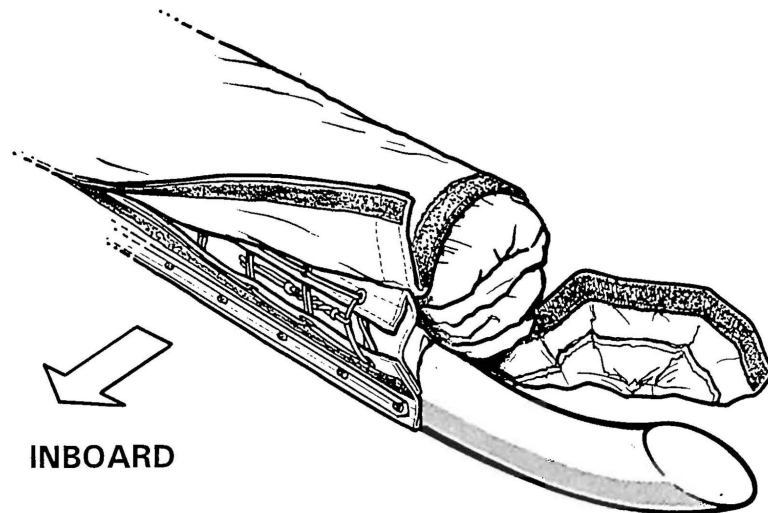

12. Verify all fasteners are properly secured and floats are rolled tightly with no lumps or loose areas.

5.660 Pressure Cylinder Removal (see Figure 5-6A)**WARNING**

Cylinder contents are under extreme pressure. Install locking pin in pressure cylinder valve (see Figure 5-6A) when working in forward left baggage compartment, during cylinder removal or installation, and when working on pop-out floats or inflation hoses.

1. Install locking pin in valve.
2. Disconnect D674-1 line assembly at valve fitting. Install protective caps on valve and line fittings.
3. Remove D675-9 cover.
4. On B125-2 connector, cut & remove ty-rap closest to valve. Disconnect connector from valve cable.
5. Disconnect D675-10 support from valve. Do not kink cable.
6. Remove D669-3 strap.
7. Carefully remove pressure cylinder.
8. If cylinder has been discharged, order KI-167 Cylinder Valve Service and Fill kit.

NOTE

If cylinder requires depressurization for transportation, use KI-151 Pop-Out Float Cylinder Bleed-Off Kit.

5.665 Filling Pressure Cylinder (See Figure 5-6)

WARNING

ONLY cylinders labeled "DOT-E 10915-4945" may be refilled. Cylinders labeled "DOT-E 10915-4500" must be returned to RHC for exchange/upgrade.

Maximum cylinder life is 15 years from date of manufacture and maximum hydro-test interval is 5 years. Also, maximum interval in aircraft between inspections is 3 years. Therefore returning to service cylinders older than 12 years or having hydro-tests older than 2 years is not recommended unless alternate arrangements are made to ensure life/hydro-test limits are not exceeded.

All fill equipment (pumps, hoses, fittings, etc.) must be rated for 6000 psi minimum working pressure and be in good condition.

Cylinder temperature and pressure must be kept within safe limits. Monitor pressure gauge and use thermocouple or other appropriate temperature probe to monitor temperature on face of thermal relief fitting during fill. Do not allow temperature to exceed 50°C (122°F) or pressure to exceed 5500 psig. If limits are approached, stop fill and allow cylinder to cool and pressure to drop before continuing. Placing cylinder in a water bath and using slow to moderate fill rates is recommended. If using water bath, keep water level below valve assembly to avoid water contamination of valve.

1. Remove fill-port cap.
2. Install MT546-2 Adapter Assembly per Figure 3 (Torque 40 in-lb).
3. Attach fill hose to MT546-2 Adapter Assembly.
4. Fill with 99.98% minimum purity (industrial grade) helium per chart below:

Ambient Temp (°C)	Pressure (psig)
-20	4268
-10	4437
0	4606
10	4776
20	4945
30	5114
40	5283

5. Allow cylinder and valve to cool to ambient temperature. Top off with helium to compensate for any pressure loss due to cooling.
6. Remove fill hose and re-install fill-port cap (Torque 40 in-lb).

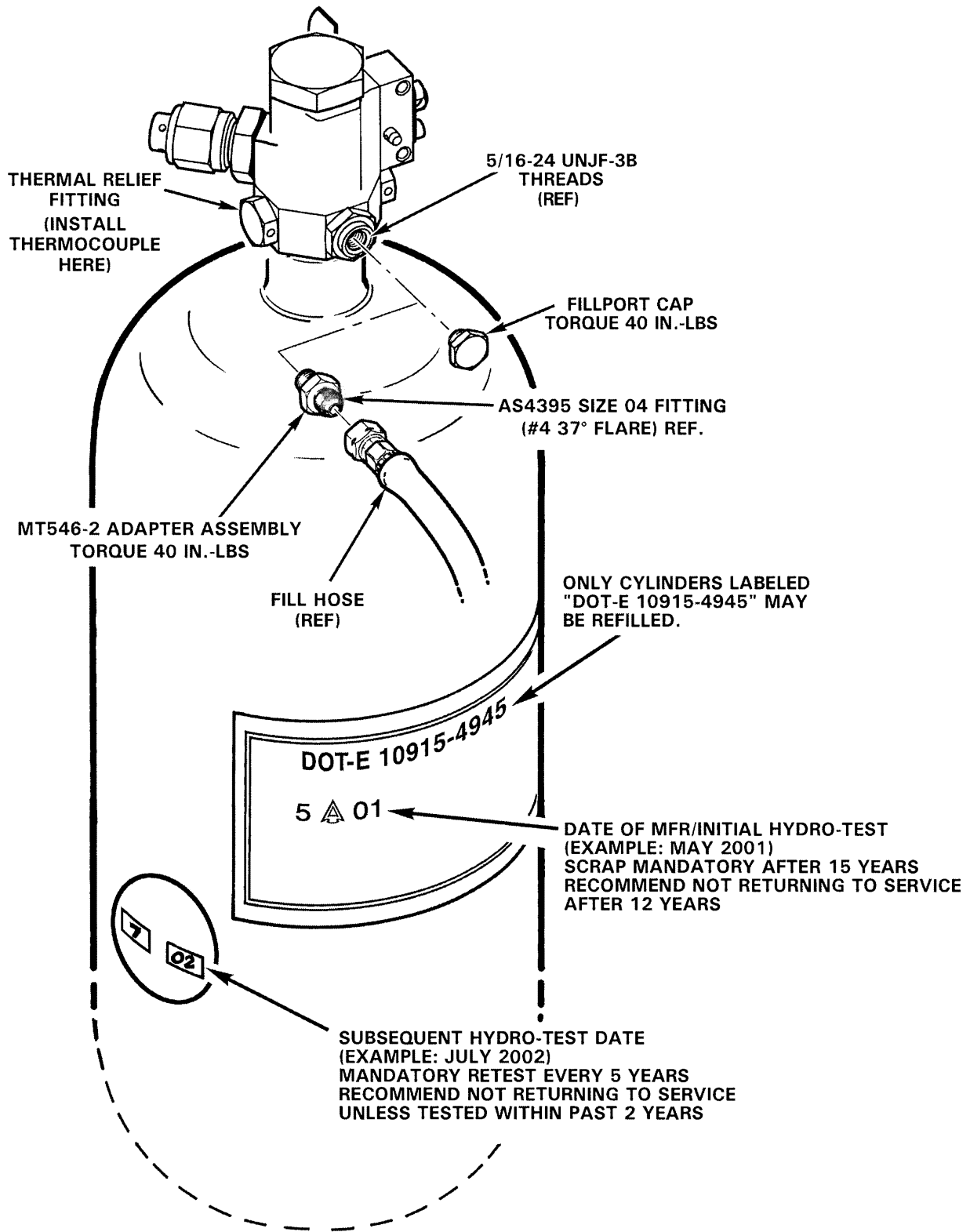

FIGURE 5-6 FILLING PRESSURE CYLINDER

5.670 Pressure Cylinder Installation (see Figure 5-6A)**WARNING**

Cylinder contents are under extreme pressure. Install locking pin in pressure cylinder valve (see Figure 5-6A) when working in forward left baggage compartment, during cylinder removal or installation, and when working on pop-out floats or inflation hoses. **Remove locking pin when work is completed.**

1. Install locking pin in valve.
2. Ensure cylinder's three forward contact areas are covered with anti-chafe tape.
3. Carefully position cylinder into D669 strap and D669 cradle per Figure 5-6A.
4. Install D675-10 support on valve.
5. See Figure 5-6B. Connect valve cable to B125-2 connector and secure with ty-rap. Verify dimension shown.
6. Install D675-9 cover on valve.
7. Rotate cylinder as required to minimize cable bending and ensure clearance with surrounding structure. Install D669-3 strap.
8. Connect D674-1 hose assembly to valve fitting. Orient line as required to maintain minimum 0.25 inch clearance to cylinder and C390-5 panel. Torque B-nut per Section 1.330 and torque stripe.
9. Rig inflation lever per Section 5.680.
10. Replace inflation lever shear rivet per Section 5.690.
11. Remove locking pin from valve.

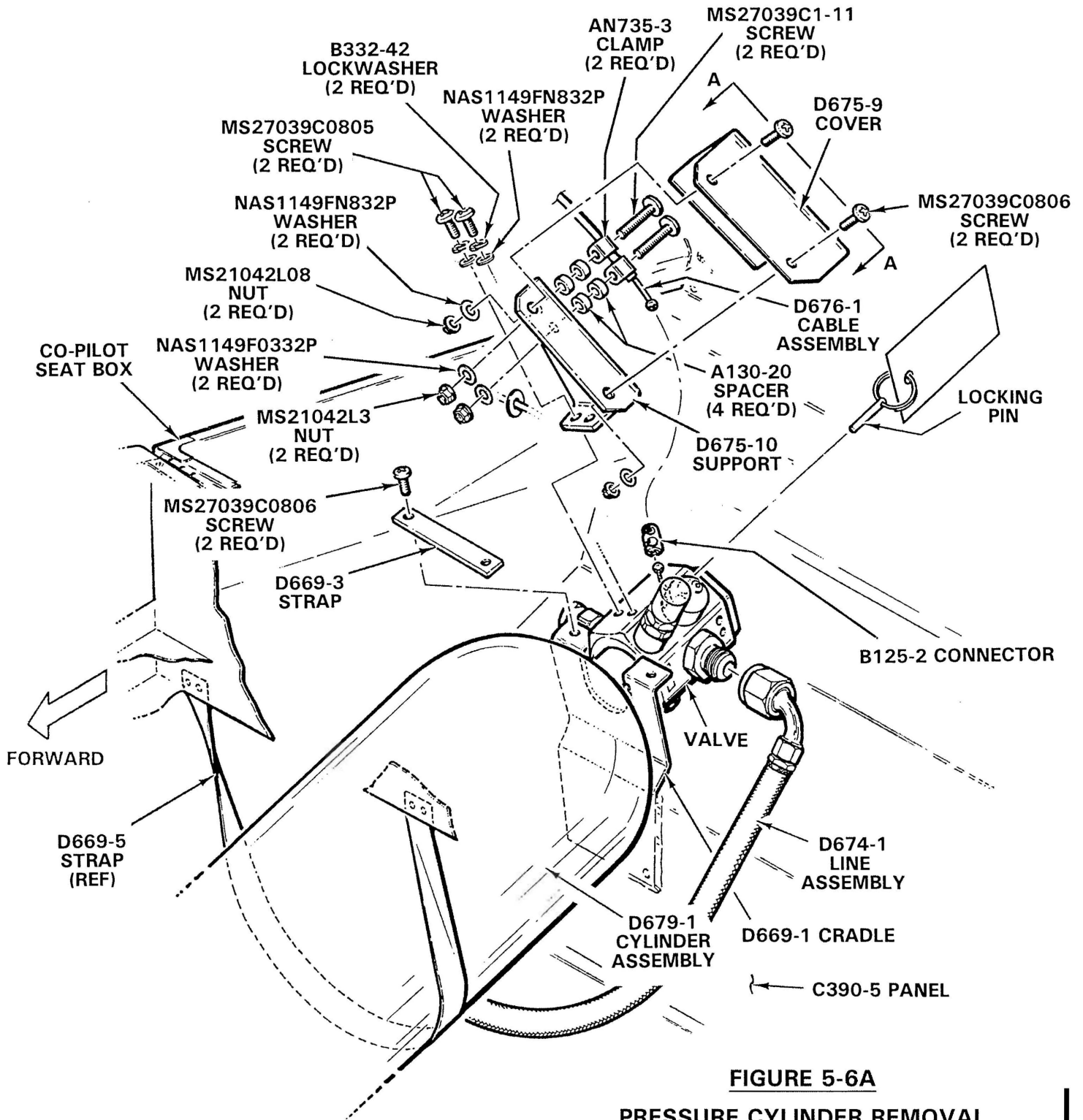
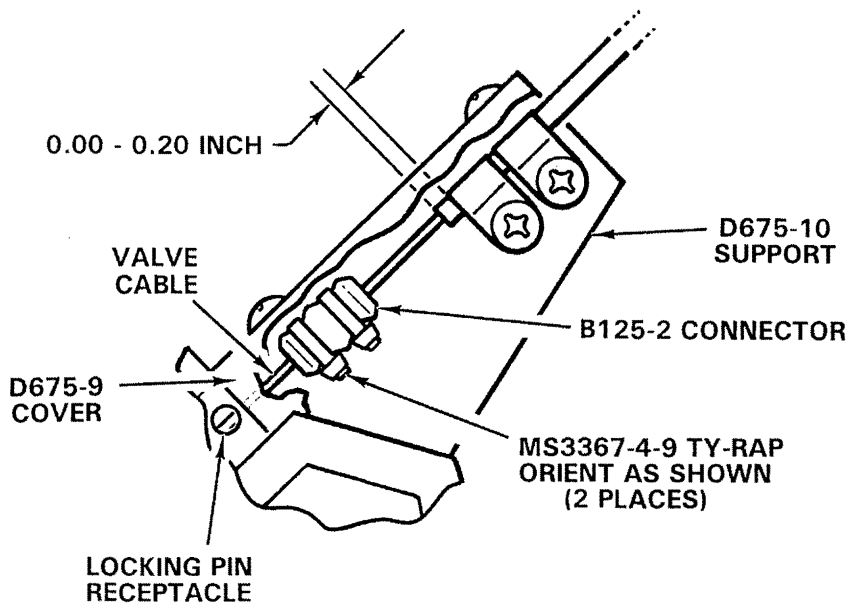

FIGURE 5-6A
PRESSURE CYLINDER REMOVAL
AND INSTALLATION



**VIEW A-A FROM FIGURE 5-6
(VIEW LOOKING FORWARD)**

FIGURE 5-6B

5.680 Inflation Lever Rigging**WARNING**

Cylinder contents are under extreme pressure. Install locking pin in pressure cylinder valve (see Figure 5-6A) when working in forward left baggage compartment, during cylinder removal or installation, and when working on pop-out floats or inflation hoses.

1. Install locking pin in valve.
2. See Figure 5-7. With inflation lever safety in READY position, collective full up, and no shear-riquet installed, verify 1.30/1.25 inch dimension shown when inflation lever is squeezed to eliminate slack. If required, reposition cable housing in clamps at inflation lever to obtain 1.30/1.25 inch dimension.
3. Place inflation lever safety in LOCKED position. Verify no preload in cable thru full travel of collective with inflation lever squeezed against safety.
4. Replace inflation lever shear rivet per Section 5.690.

5.690 Inflation Lever Shear-Rivet Replacement

1. Before installing rivet, verify inflation lever rigging per Section 5.680.

WARNING

Cylinder contents are under extreme pressure. Install locking pin in pressure cylinder valve (see Figure 5-6) when working in forward left baggage compartment, during cylinder removal or installation, and when working on pop-out floats or inflation hoses. Remove locking pin when work is completed.

2. Install locking pin in valve.
3. See Figure 5-7. Place inflation lever safety in LOCKED position.
4. Insert MS20470A2-6-5 (or MS20470A2-6.5) rivet per Figure 5-7.

WARNING

Use only MS20470A2 series annealed rivet in inflation lever assembly; other hardware may prevent float inflation.

5. Using locking pliers or similar, flatten shop-head end of rivet per Figure 5-8.
6. Remove locking pin from valve.

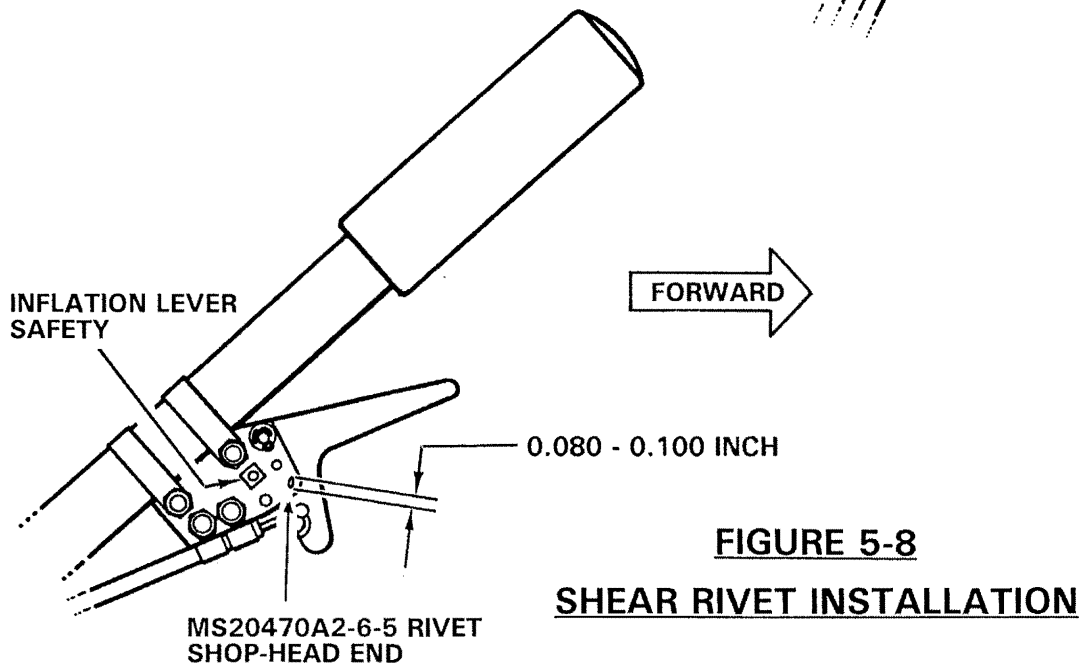
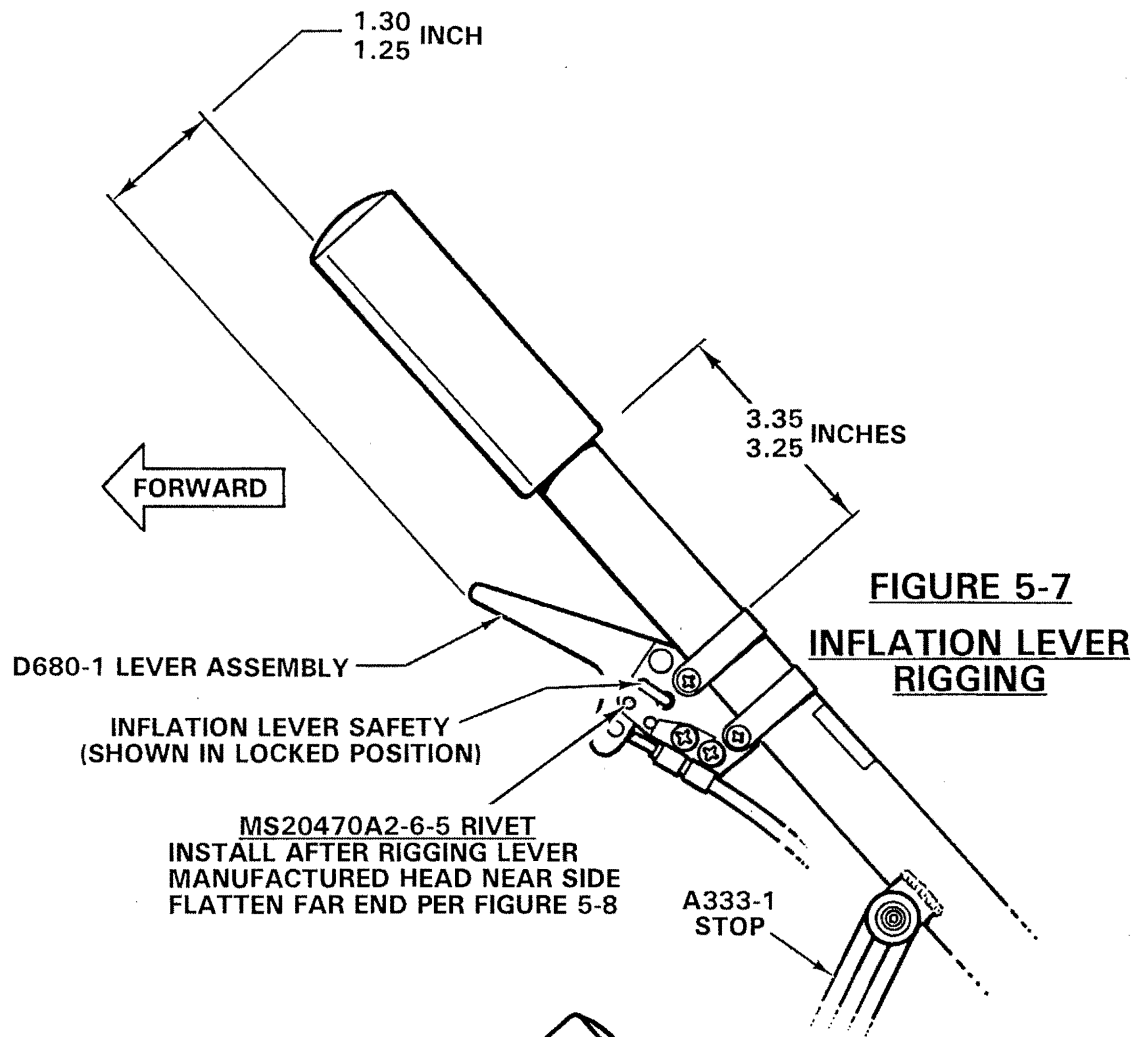

5.700 MAINTENANCE

1. Ensure drain holes in bottoms of skid tubes are not plugged (two per skid, standard and pop-out gear only), located between the two forward skid shoes and just aft of the skid shoe at the forward strut.
2. Touch up skid tubes, cross tubes and struts to prevent corrosion. See Section 1.400 for approved materials.
3. Inspect skid shoes frequently, especially following touch-down autorotations or running take-offs or landings.
4. Install lost or loose raincaps with B270-1 or B270-9 adhesive (see Section 1.480). Mix adhesive per manufacturer's instructions.

Intentionally blank