

CHAPTER 24**AUTOPILOT**

<u>Section</u>	<u>Title</u>	<u>Page</u>
24-00	Description	24.1
24-10	(Pitch) Servo Assembly	24.7
24-20	(Roll) Servo Assembly	24.8
24-30	Flight Control Computer (FCC)	24.9
24-40	Control Panel	24.10
24-50	Cyclic Grip Assembly	24.11
24-60	Maintenance	24.12
24-61	Ground Checks	24.12
24-62	Troubleshooting	24.14

Intentionally Blank

CHAPTER 24

AUTOPILOT

24-00 Description

The HeliSAS autopilot system consists of two electric servomotors, a flight control computer, an autopilot control panel, and control buttons on the cyclic grip. One servomotor controls pitch and is installed in the control tunnel forward of the cyclic stick. The other servomotor controls roll and is installed under the pilot's seat. The servomotors are connected to the cyclic through electromagnetic clutches.

The flight control computer is installed on the forward panel under the pilot's seat, and the autopilot control panel is installed in the avionics stack.

The autopilot senses aircraft attitude using a combination of sensors in the flight control computer and an independent onboard attitude source such as the Attitude Heading Reference System (AHRS) for the Primary Flight Display (PFD). The computer then sends signals to the servomotors which are connected to the bottom of the cyclic in the control tunnel.

The primary autopilot mode is Stability Augmentation System (SAS) mode which maintains a steady helicopter attitude by applying corrective inputs to the cyclic. This is felt as a light cyclic centering force. Additional modes may be layered on top of SAS mode and are described below. The pilot can override as desired for maneuvering without disengaging the system. Only a few pounds of force at the cyclic are required for override, and the system will not disconnect due to pilot cyclic inputs.

The control panel has a row of buttons to control autopilot modes and annunciators to indicate mode status. A dark annunciator indicates that a mode is off, a white annunciator indicates that a mode is armed or on standby, and a green annunciator indicates that a mode is active.

When the avionics master is switched on, the autopilot performs a self-test and then enters SAS standby mode. All of the control panel indicators flash alternating white and green during the self-test. Four headset beeps occur at the beginning of the self-test as a check of the aural warning function. The SAS annunciator on the control panel turns steady white when the self-test is complete.

NOTE

Autopilot will not enter standby mode if attitude indicator is not functioning or indicated bank angle is greater than 6 degrees.

The autopilot SAS mode is engaged either by pressing the SAS button on the control panel or by pressing the TRIM button on the cyclic for more than 1.25 seconds. Additional modes are engaged by pressing the appropriate button on the control panel. The additional modes are disabled and will not engage at airspeeds below 44 KIAS or above 130 KIAS.

24-00 Description (continued)

To disengage any mode, push the appropriate button on the control panel.

NOTE

Disengaging SAS mode will also disengage all other modes.

Modes may also be disengaged using the AP OFF button on the cyclic. If only SAS mode is engaged, push the AP OFF button once to disengage. If additional modes are engaged, push the AP OFF button once to disengage all modes except SAS and a second time to disengage SAS mode, or push and hold the AP OFF button to disengage all modes including SAS.

NOTE

SAS disengagement should always be accompanied by four beeps in the headset. If beeps do not occur, maintenance is required.

Safety monitors automatically disengage individual modes or the entire system if a fault is detected. Automatic disengagement of SAS mode (or the entire system) is indicated by four beeps in the headset. Automatic disengagement of any mode other than SAS is indicated by a single beep in the headset. There is no audio indication for intentional disengagement of modes other than SAS.

NOTE

The system also automatically reverts to SAS mode at airspeeds below 44 KIAS or above 130 KIAS, accompanied by a single beep. The high speed limit is not intended to provide V_{ne} protection. It is the pilot's responsibility to observe V_{ne} limits.

The TRIM button is used to re-set the target attitude (to re-trim) while in SAS mode. Use a small amount of force to override the autopilot and then push and release the TRIM button at the new desired condition. If the force to override is objectionable, the TRIM button may be held down during maneuvers. The system will re-trim to the attitude at which the TRIM button is released. For Version 52, stick forces felt during override will gradually wash out to near zero without use of TRIM button if override is maintained.

NOTE

The system will not re-trim to angles more than approximately 10° in pitch or roll.

24-00 Description (continued)

NOTE

When engaging SAS mode from standby, for angles of less than approximately 10° in pitch and roll, SAS holds the current angles. If either pitch or roll is larger than approximately 10°, the system assumes an unusual attitude and gently levels the helicopter.

The autopilot is protected by a dedicated circuit breaker on the avionics bus (autopilot is not powered with the avionics master switch off).

Heading Mode (HDG) – maintains the heading selected by the heading bug on the directional gyro or Horizontal Situation Indicator (HSI) display. Aircraft can be steered using the heading bug.

Altitude Mode (ALT) – maintains altitude at the time of engagement or of last TRIM button release. The target altitude is reset each time the TRIM button is pressed and released.

NOTE

The autopilot uses pitch attitude to maintain altitude or follow an approach glidepath. It does not have any control of power setting. The pilot must manage power with the collective to control speed and rate of climb or descent. Make small, smooth power changes to allow the system to adjust to new power settings.

Navigation Mode (NAV) – tracks the active GPS or VLOC course displayed on the Course Deviation Indicator (CDI). If no CDI is installed, NAV will only track the active GPS course displayed on the GPS.

NAV may be armed prior to intercepting the active course. NAV annunciator is white when NAV is armed and turns green at course intercept. If HDG is active when NAV is armed, the autopilot will fly the selected heading until course intercept. If HDG is not active, the autopilot will select a 45° intercept angle.

24-00 Description (continued)

Vertical Navigation Mode (VRT) – tracks an ILS glideslope or GPS approach vertical guidance. Arm VRT (annunciator turns white when armed) prior to intercepting the glidepath. VRT annunciator will turn green at glidepath intercept.

NOTE

Pushing the ALT button while VRT is armed or active will turn off VRT. VRT must be re-armed or re-engaged as desired.

NOTE

Reducing power to approach setting just prior to glidepath intercept is recommended.

Speed Mode (SPD) (Version 52 only)

Speed mode uses cyclic pitch to control airspeed. Exact behavior varies with configuration of airspeed and altitude bugs on the PFD as described below.

The altitude bug is displayed above the altitude tape and the airspeed bug is displayed above the airspeed tape. The appearance of all dashes or a blank field indicates a bug is not set.

If an airspeed bug is not set, selecting SPD holds the current airspeed. The target speed is reset each time the trim button is pressed and released.

If an airspeed bug is set, selecting SPD holds airspeed at the bug setting. Changing the bug will change the target airspeed.

If an altitude bug is set, selecting SPD will also arm ALT (ALT LED white) for altitude capture. The mode will switch from SPD to ALT if the selected altitude is crossed. There will be a brief period in capture mode with the ALT LED flashing white/green.

NOTE

Do not change the selected altitude during ALT capture (ALT LED flashing white/green). System may pitch up or down to chase bug and may not capture altitude.

24-00 Description (continued)

NOTE

Different brands of PFD behave differently in terms of bug settings at power up and how bugs are manually set. Refer to PFD manufacturer's documents for proper use. Verify desired bug settings before engaging SPD mode.

Backcourse Mode (BC) (Version 51 only) – reverse CDI sensing for backcourse approaches.

Course on HSI should be set so that tail of course pointer points toward runway (set to inbound front course).

Airspeed Protection (Version 52 only) – Minimizes the possibility of the ALT mode to fly the helicopter to an airspeed below 44 KIAS due to insufficient power, or the VRT mode to fly the helicopter to an airspeed above 130 KIAS due to excess power when flying a precision approach glidescope. When triggered, it causes the longitudinal mode to change from ALT (at low airspeed) or VRT (at high airspeed) to SAS mode with a commanded pitch attitude of 2 degrees nose down. Since the mode change is not commanded by the pilot, a single warning beep is annunciated.

A. Removable Flight Controls

Disconnect the electrical connector for the left-hand trim button located near the quick release pin before removing the left cyclic grip. Reconnect the connector when installing the left cyclic grip.

B. Schematic

Refer to Figures 14-32A & 14-32B for autopilot (HeliSAS) electrical schematic.

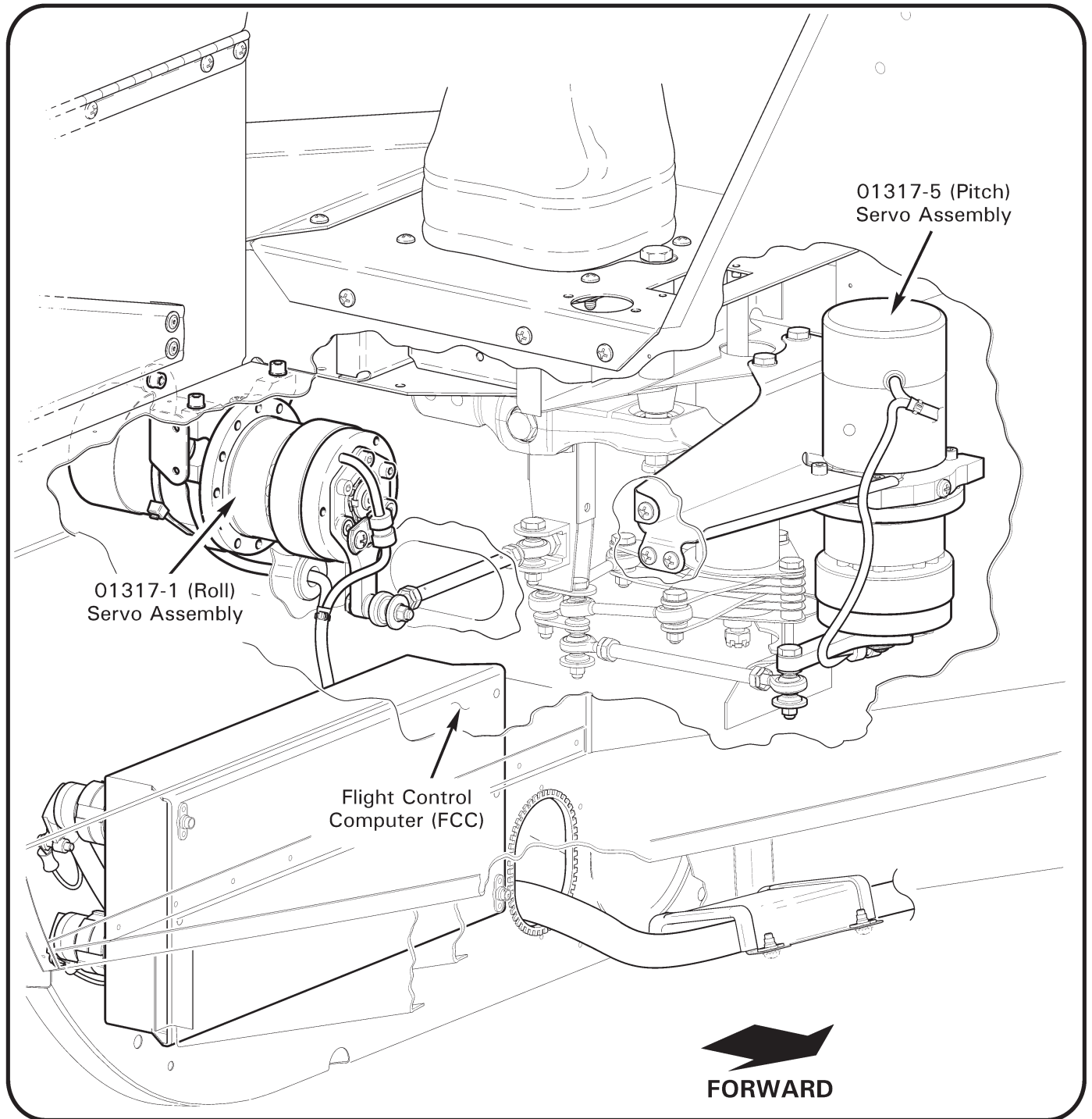

FIGURE 24-1 HELISAS AUTOPILOT SYSTEM

24-10 (Pitch) Servo Assembly**A. Removal**

1. Turn battery & avionics switches off and pull out AUTOPILOT (5 amp) circuit breaker at panel.
2. Remove C680-5 and C445 collective covers and C444 cyclic cover. Hinge front right seat forward. Remove C748-6 cover assembly under pilot's seat.
3. Remove avionics and avionics trays as required from lower console.

CAUTION

For pitch servo, adjust length of A336-7 push-pull tube assembly to 5.00 ± 0.03 inches between rod end centers.

4. Position cyclic stick full aft and apply cyclic friction. Remove hardware securing 01317-5 (pitch) servo assembly arm to A336-7 push-pull tube's rod end.
5. Disconnect servo harness from flight control computer's J1 PITCH receptacle. Cut and discard ty-rap(s) securing harness to M23190/1-2 clamp(s) and pull harness through access holes into control tunnel.
6. Support servo and remove hardware securing servo's brace to cyclic box and keel panels. Carefully remove servo from control tunnel.

B. Installation

1. Turn battery & avionics switches off and pull out AUTOPILOT (5 amp) circuit breaker at panel. Position cyclic stick full aft and apply cyclic friction.
2. Position 01317-5 (pitch) servo assembly in control tunnel and install hardware securing servo's brace to cyclic box. Standard torque bolts per § 23-32 and torque stripe per Figure 2-1. Install screws securing brace to keel panels. Verify security.
3. Route servo harness through access holes and connect harness to flight control computer's J1 PITCH receptacle. Install ty-rap(s) securing harness to M23190/1-2 clamp(s). Cinch ty-raps until snug without over-tightening, and trim tips flush with heads. Verify harness security.
4. Install hardware securing servo arm to A336-7 push-pull tube's rod end. Standard torque bolt per § 23-32 and torque stripe per Figure 2-1. Verify security.
5. Verify length of A336-7 push-pull tube assembly connected to pitch servo is 5.00 ± 0.03 inches between rod end centers.
6. Verify freedom of flight controls through full travel with and without friction applied.
7. Install avionics trays and avionics if removed. Verify security.
8. Push in AUTOPILOT circuit breaker (5 amp) at panel. Perform ground checks as appropriate per § 24-61.
9. Install C748-6 cover assembly under pilot's seat. Install C444 cyclic cover, and C445 and C680-5 collective covers. Verify security.

24-20 (Roll) Servo Assembly**A. Removal**

1. Turn battery & avionics switches off and pull out AUTOPILOT (5 amp) circuit breaker at panel.
2. Remove C680-5 and C445 collective covers. Remove C748-6 cover assembly under pilot's seat.

CAUTION

For roll servo, adjust length of A336-8 push-pull tube assembly to 4.20 ± 0.03 inches between rod end centers.

3. Position cyclic stick full left and apply cyclic friction. Remove hardware securing 01317-1 (roll) servo assembly arm to A336-8 push-pull tube's rod end.
4. Disconnect servo harness from flight control computer's J3 ROLL receptacle. Cut and discard ty-raps securing servo harness to autopilot harnesses.
5. Support servo and remove hardware securing servo's block assembly to keel panel and cabin assembly. Carefully remove servo from under pilot's seat.

B. Installation

1. Turn battery & avionics switches off and pull out AUTOPILOT (5 amp) circuit breaker at panel. Position cyclic stick full left and apply cyclic friction.
2. Position 01317-1 (roll) servo assembly under pilot's seat and install hardware securing servo's block assembly to keel panel and cabin assembly. Tighten screws. Verify security.
3. Connect servo harness to flight control computer's J3 ROLL receptacle. Install ty-raps securing servo harness to autopilot harnesses as required. Cinch ty-raps until snug without over-tightening, and trim tips flush with heads. Verify harness security.
4. Install hardware securing servo arm to A336-8 push-pull tube's rod end. Standard torque bolt per § 23-32 and torque stripe per Figure 2-1. Verify security.
5. Verify length of A336-8 push-pull tube assembly connected to roll servo is 4.20 ± 0.03 inches between rod end centers.
6. Verify freedom of flight controls through full travel with and without friction applied.
7. Push in AUTOPILOT circuit breaker (5 amp) at panel. Perform ground checks as appropriate per § 24-61.
8. Install C748-6 cover assembly under pilot's seat. Install C445 and C680-5 collective covers. Verify security.

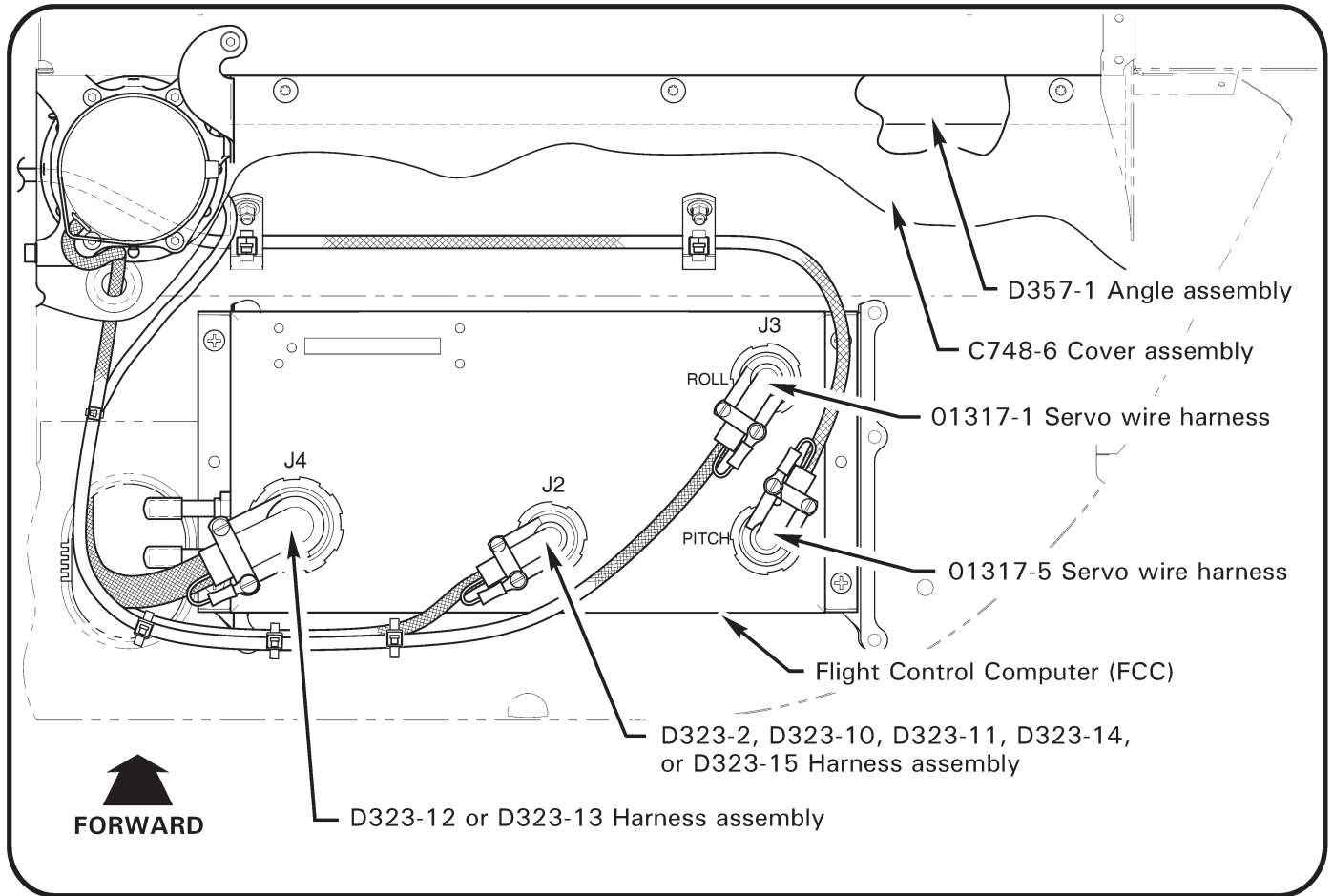

FIGURE 24-2 FLIGHT CONTROL COMPUTER

Version 51		Version 52	
FCC part number	01311-03-01	FCC part number	01311-02-101
Control panel part number	01309-01-01	Control panel part number	01309-03-01

TABLE 24-1 SOFTWARE VERSIONS AND EQUIPMENT PART NUMBERS

24-30 Flight Control Computer (FCC)

A. Removal

1. Turn battery & avionics switches off and pull out AUTOPILOT (5 amp) circuit breaker at panel.
2. Remove C748-6 cover assembly under pilot's seat.
3. Disconnect D323 harness assemblies and servo assembly harnesses from flight control computer's J1 PITCH, J2, J3 ROLL, and J4 receptacles.
4. If installed, disconnect pitot and static tubes from computer. Plug elbows and tubes.
5. Support computer and remove screws securing computer to cabin assembly. Carefully remove computer from under pilot's seat.

24-30 Flight Control Computer (continued)**B. Installation****NOTE**

Refer to Table 24-1. Flight control computer (FCC) and control panels for Software Version 51 and Software Version 52 are not interchangeable. Verify part number compatibility prior to installation.

1. Turn battery & avionics switches off and pull out AUTOPILOT (5 amp) circuit breaker at panel.
2. Position flight control computer under pilot's seat and install screws securing computer to cabin assembly. Tighten screws. Verify security.
3. If installed, remove plugs and connect pitot and static tubes to computer. Perform pitot and static system leak checks per § 13-10.
4. Connect D323 harness assemblies and D354 servo assembly harnesses to computer's J1 PITCH, J2, J3 ROLL, and J4 receptacles. Install ty-raps securing harnesses as required. Cinch ty-raps until snug without over-tightening, and trim tips flush with heads. Verify harness security.
5. Verify freedom of flight controls through full travel with and without friction applied.
6. Push in AUTOPILOT circuit breaker (5 amp) at panel. Perform ground checks as appropriate per § 24-61.
7. Install C748-6 cover assembly under pilot's seat.

24-40 Control Panel**A. Removal**

1. Turn battery & avionics switches off and pull out AUTOPILOT (5 amp) circuit breaker at panel.
2. Loosen quarter-turn fasteners securing control panel to console assembly.
3. Carefully unplug harness from control panel and remove panel.

24-40 Control Panel (continued)**B. Installation****NOTE**

Refer to Table 24-1. Flight control computer (FCC) and control panels for Software Version 51 and Software Version 52 are not interchangeable. Verify part number compatibility prior to installation.

1. Turn battery & avionics switches off and pull out AUTOPILOT (5 amp) circuit breaker at panel.
2. Carefully plug-in harness to control panel.
3. Tighten quarter-turn fasteners securing control panel to console assembly. Verify security.
4. Push in AUTOPILOT circuit breaker (5 amp) at panel. Perform ground checks as appropriate per § 24-61.

24-50 Cyclic Grip Assembly**A. Grip Angle Adjustment**

1. Loosen cap screws securing pilot's cyclic grip, block assembly, and bar to grip weldment.
2. Rotate grip about weldment to desired angle. Special torque cap screws to 40 in.-lb.

B. Removal and Installation

Refer to § 8.121 & 8.122 for cyclic grip assembly removal and installation procedures.

To access grip switches:

1. Remove MS24693-S1 screws securing C214-27 plate to D379-1 grip. Remove switch nuts and lockwashers to free switches from plate.
2. Install switch lockwashers (new) and nuts and tighten switches to plate; verify switch security. Install screws securing plate to grip.
3. Turn battery switch on and perform ground checks as appropriate per § 24-61.

C. Schematic

Refer to Figure 14-21 for C024 electrical system schematic.

24-60 Maintenance

24-61 Ground Checks

NOTE

Perform the following ground checks after component replacement or other repairs have been performed on the autopilot system. Perform ground checks after any incident that may have affected autopilot or related equipment prior to return to service.

NOTE

Refer to § 24-62 for troubleshooting if any of the following ground checks cannot be verified.

1. Turn battery & avionics switches on. Verify four beeps in headset and control panel LEDs alternate white/green:

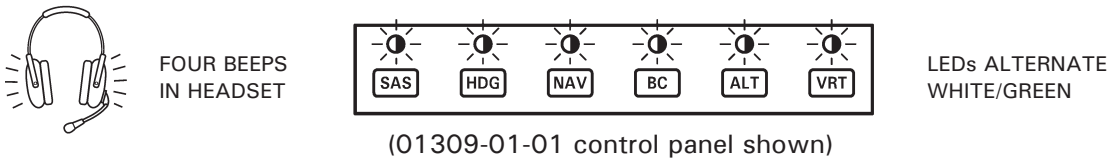

2. Verify SAS enters standby mode approximately 6 seconds after PFD aligns. Verify no sound in headset and control panel SAS LED is white, other LEDs are dark:

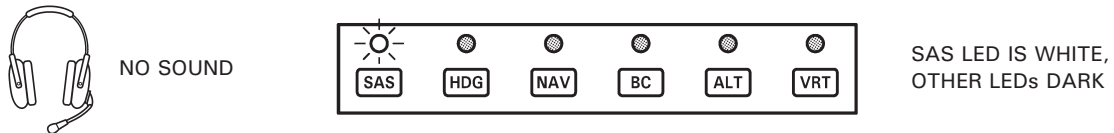

3. With cyclic friction full off, verify cyclic moves freely within hydraulic servo longitudinal and lateral deadbands.
4. Engage SAS mode (cyclic should feel "energized"). Verify no sound in headset and control panel SAS LED is green, other LEDs are dark:

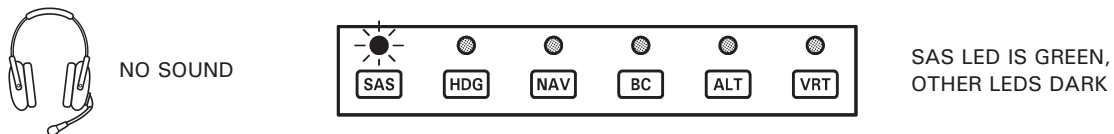

5. With SAS engaged, displace cyclic at least 1 inch from neutral position and verify a vibrating resistance is encountered. Perform check for roll & pitch axes.

24-61 Ground Checks (continued)

6. Refer to step 2. Engage SAS and verify SAS disengages when control panel's SAS button is depressed or when AP OFF button on the cyclic grip is depressed. Verify four beeps in headset and control panel SAS LED is white, other LEDs are dark:



FOUR BEEPS
IN HEADSET

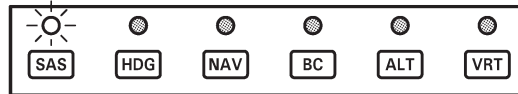

SAS LED IS WHITE,
OTHER LEDS DARK

7. Perform pitot system leak test per § 13-10 and, while airspeed indicates > 50 knots: Engage SAS and ALT modes. Verify no sound in headset and SAS & ALT LEDs are green, other LEDs are dark:



NO SOUND

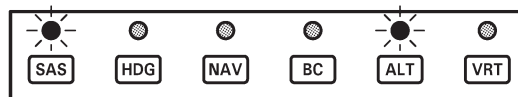

SAS & ALT LEDs ARE
GREEN, OTHER LEDS
DARK

8. Disengage ALT mode. Verify no sound in headset and SAS LED is green, other LEDs are dark:



NO SOUND

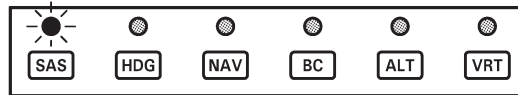

SAS LED IS GREEN,
OTHER LEDS DARK

9. Refer to steps 7 & 8. Engage SAS and HDG modes. Verify no sound in headset and SAS & HDG LEDs are green, other LEDs are dark. Disengage HDG mode. Verify no sound in headset and SAS LED is green, other LEDs are dark.
10. Engage SAS, HDG, and ALT modes. Verify no sound in headset and SAS, HDG, and ALT LEDs are green, other LEDs are dark. Press AP OFF button on cyclic grip. Verify no sound in headset and SAS LED is green, other LEDs are dark.
11. Engage SAS, HDG, and ALT modes. Verify no sound in headset and SAS, HDG, and ALT LEDs are green, other LEDs are dark. Press AP OFF button twice on cyclic grip. Verify four beeps in headset and SAS LED is white, other LEDs are dark.

24-62 Troubleshooting

CAUTION
Adjustment to autopilot equipment is not permitted.

PROBLEM	ACTION
Control panel lights do not illuminate or flash when master switch is turned on.	Verify computer is getting power.
	Return computer to RHC.
System does not enter standby-mode (lights flash continuously).	Verify attitude indicator bank angle less than 6 degrees.
	Verify attitude indicator output between 13 and 14 pins is less than 0.3 volts at connector.
	Check wiring between attitude indicator and computer.
	Contact RHC Technical Support.
SAS does not engage when TRIM button depressed for longer than 1.25 seconds; pressing TRIM button does not reset reference attitude; pressing TRIM button does not reset reference altitude in altitude hold.	Check wiring between TRIM button and computer.
	Verify integrity of TRIM button.
	Return computer to RHC.
SAS does not disengage when cyclic grip AP OFF button depressed.	Check wiring between AP OFF button and computer.
	Verify integrity of AP OFF button.
	Return computer to RHC.
SAS does not engage or disengage when control panel buttons pressed.	Engage and/or disengage SAS using cyclic grip buttons. If system responds properly, failure is in control panel or associated wiring to computer.
	Contact RHC Technical Support.
SAS does not hold pitch attitude, but holds roll attitude or vice versa.	Check servo-to-cyclic linkage.
	Check wiring between faulty servo and computer.
	Return faulty servo and computer to RHC.
SAS disengages unintentionally (accompanied by four beeps in headset).	Contact RHC Technical Support.
Autopilot mode disengages unintentionally, and reverts to SAS mode (accompanied by single beep in headset).	Determine if navigation signal may have gone invalid due to operational reason.
	Check wiring between appropriate instrument/avionics and computer.
	Check instrument/avionics for failure flags (steady and intermittent).
Cyclic vibrates erratically, SAS does not disengage.	Manually override SAS, system should disengage automatically.
	Contact RHC Technical Support.
Helicopter enters low frequency pitch oscillation when ALT engaged; helicopter diverges nose-up or nose-down when ALT engaged.	Return computer to RHC.

24-62 Troubleshooting (continued)

PROBLEM	ACTION
ILS glideslope tracking performance is poor.	Check for excessive friction in longitudinal cyclic.
	Check GPS output to computer.
Cyclic force seems higher than normal with SAS disengaged.	Verify servo clutches are disengaged, and clutch arms do not move when SAS is Off or in standby-mode.
No aural warning in headset when SAS is disengaged.	Check wiring to unswitched audio input to audio panel.

Intentionally Blank