

**R66 Five-Point Harness Installation Kit Instructions**

*Converts existing standard harness & buckle installation to five-point harness installation.*

**NOTE**

Visit [www.robinsonheli.com](http://www.robinsonheli.com) to verify kit instructions are current revision. Review instructions before installation; contact RHC Technical Support with questions. Verify kit contents match list; contact RHC Customer Service if parts are missing or damaged.

ITEM	PART NUMBER	KIT CONTENTS	QTY
1	KI-155-3Instr.	Kit Instructions .....	1
2	A130-28	Spacer .....	4
3	A141-14	Washer .....	3
4	A141-17	Washer .....	8
5	B340-8	Nut .....	8
6	B340-10	Nut .....	3
7	C421-6	Tube .....	1
8	C421-7	Fitting .....	2
9	C627-6	Harness Assembly – Five-Point .....	2
10	C680-4	Cover .....	1
11	D210-3	Nut .....	8
12	D210-4	Nut .....	3
13	F423-4	Tube Assembly – Upper .....	1
14	F424-1XXX	Bumper Assembly (select p/n below to match interior) .....	1
	F424-1CHL	Bumper Assembly – Charcoal Leather .....	0
	F424-1GRL	Bumper Assembly – Gray Leather .....	0
	F424-1TNL	Bumper Assembly – Tan Leather .....	0
15	F426-1	Stiffener .....	2
16	F426-2	Anchor .....	2
17	2663+	Hole Plug – DP-625 (Note: “+” in part number indicates 5-qty pack) .....	1
18	MS20002-4+	Washer (Note: “+” in part number indicates 10-qty pack) .....	1
19	MS20470AD3-3.5+	Rivet (Note: “+” in part number indicates 50-qty pack) .....	1
20	MS21042L08	Nut .....	4
21	MS27039C0806	Screw .....	4
22	MS27039C0807	Screw .....	1
23	MS27039C0808	Screw .....	9
24	MS27039C0809	Screw .....	6
25	MS27039C1-05	Screw .....	4
26	MS27039C1-06	Screw .....	4

ITEM	PART NUMBER	KIT CONTENTS (continued)	QTY
27	MS27039C1-07	Screw .....	8
28	NAS1149FN816P+	Washer (Note: "+" in part number indicates 20-qty pack) .....	1
29	NAS1149FN832P+	Washer (Note: "+" in part number indicates 20-qty pack) .....	1
30	NAS1149F0332P+	Washer (Note: "+" in part number indicates 20-qty pack) .....	1
31	NAS1149F0432P+	Washer (Note: "+" in part number indicates 20-qty pack) .....	1
32	NAS6604-5	Bolt .....	1
33	NAS6604-6	Bolt .....	3
34	NAS6604-17	Bolt .....	2
35	NAS9301B-5-04	Rivet .....	8
36	NAS9301B-5-06	Rivet .....	3

**Consumables**

Refer to R66 Maintenance Manual (MM) § 20-70 for approved materials list.

- Primer paint

**Kit Instructions**

1. Remove forward seat harnesses per MM § 25-11.
2. Refer to Figure 1A. Install (4) MS27039C1-06 screw, (4) NAS1149F0332P washer, and (4) B340-8 nut in former harness inertia reel mounting holes as shown. Standard torque fasteners per MM § 20-32 and torque stripe per MM Figure 5-1.
3. Refer to Figure 1. Remove F680-1 (removable collective) cover assembly. Temporarily install C680-4 cover to forward outboard nutplate of F373-3 cover using existing screw. Match drill & cleco (2) 0.098-inch diameter holes in F373-3 cover, thru pilot holes of C680-4 cover as shown. Remove C680-4 cover; deburr holes & clean up debris. Install C680-4 cover using existing screw in forward outboard nutplate. Install (2) MS20470AD3-3.5S rivets in newly-drilled holes. Remove forward screw and verify cover security.
4. Install NAS6604-17 bolt (bolt head outboard) and B340-10 nut in each F403 door post where shoulder strap guides were installed. Standard torque fasteners per MM § 20-32 and touch-up bolt heads using approved primer.
5. Perform the following steps on LH and RH sides of helicopter:
  - a. Refer to Figure 2. Remove existing (3) MS27039C0807 screws in F403 door post where F423-4 tube is to be installed. Install F426-1 stiffener onto F403 door post using (3) MS27039C0809 screws. Verify rivet heads in door post are centered in stiffener clearance holes.
  - b. Using F426-1 stiffener holes as pilot holes, match drill four 0.159-inch diameter holes in door post as shown. Deburr holes and clean up debris. Install (4) NAS9301B-5-04 rivets. Remove screws and verify stiffener security.
6. Locate existing hole on the bottom in the center of F423-4 tube. Attach (upper) C421-7 fitting to tube using NAS9301B-5-06 rivet.

**Kit Instructions (continued)**

7. Temporarily assemble (lower) C421-7 fitting in C421-6 tube, and install C421-6 tube on F423-4 tube's fitting. Position assembly in helicopter. Align F423-4 tube and door post mounting holes. Verify C421-6 tube is parallel with posts, and that lower fitting is centered on, and conforms to the contour of, F423-1 tube. Mark location of lower fitting on F423-1 tube. Remove assembly.
8. Drill 0.159-inch diameter hole in F423-1 tube in center of marked fitting location. Deburr hole & clean up debris. Attach lower fitting to tube using NAS9301B-5-06 rivet and install C421-6 tube on fitting. Position F423-4 tube's fitting on C421-6 tube and install (6) MS27039C0809 screws securing F423-4 tube to door posts. Verify security.
9. Refer to Figure 3. Perform the following on LH and RH sides of helicopter: Remove C627-6 harness assembly inertia reel cover. Using reel's mounting plate holes as pilot holes, drill (4) 0.191-inch diameter holes thru F370-1 (LH) and F369-3 (RH) panels as shown. Deburr holes & clean up debris.
10. Drill (2) 0.641-inch diameter holes thru seat back as shown. Deburr holes & clean up debris.
11. Install hardware securing reel to F370-1 or F369-3 panel and verify reel security. Standard torque fasteners per MM § 20-32 and torque stripe per MM Figure 5-1. Install (2) DP-625 (or 2663) hole plugs in seat back as shown. Install reel cover.
12. Refer to Figure 2. Drape harnesses over F423-4 tube, and install hardware securing F424-1 bumper to tube.
13. Refer to Figure 1. Install hardware securing inboard and outboard harness lap belts as shown. Standard torque fasteners per MM § 20-32 and torque stripe per MM Figure 5-1. Install F680-1 (removable collective) cover assembly, noting F680-4 cover inboard forward hole remains open.
14. Refer to Figure 4. Perform the following on LH and RH sides of helicopter: Using fifth-point F426-2 anchor mounting holes as pilot holes, position anchor under seat hinge as shown and drill (2) 0.170-inch diameter holes thru F290-1 or F297-1 seat support. Install hardware securing fifth-point to seat support and verify security.
15. Each harness: Buckle all points and verify webbing is untwisted. Pull shoulder harness with a sudden quickness to verify proper function of inertia reel locking mechanism.
16. Revise helicopter's Weight and Balance Record in R66 Pilot's Operating Handbook (POH) Section 6 to reflect this installation by incorporating the following data. Weight and Balance change is negligible.

**Remove:**

Item	Weight	Long. Arm	Long. Moment
Standard Harness Installation	Weigh all equipment removed and subtract item	+55.2 in.	0 in-lb

**Add:**

Item	Weight	Long. Arm	Long. Moment
Five-point Harness Installation	+8.10 lb	+64.5 in.	+522.5 in-lb

17. Make appropriate maintenance record entries.

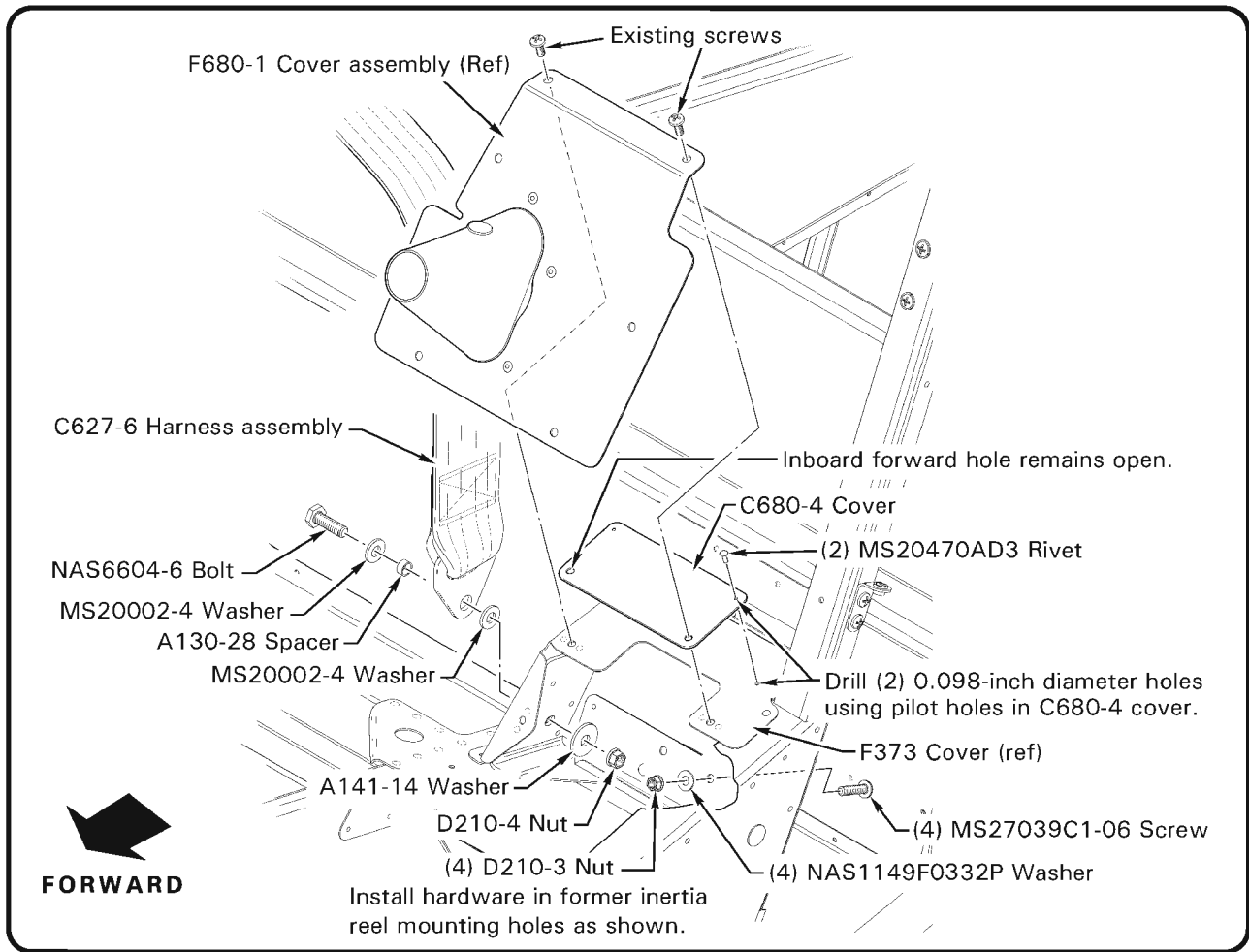

**FIGURE 1**  
(harness installation, outboard LH side)

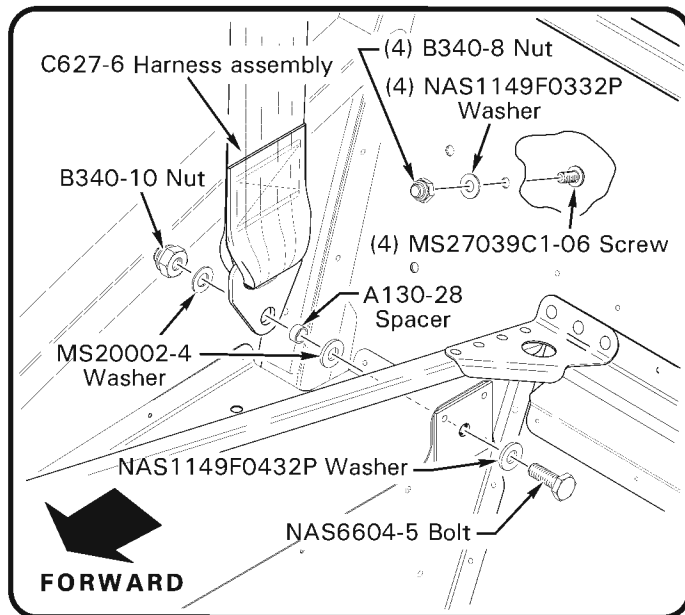

**FIGURE 1A**  
(harness installation, outboard RH side)

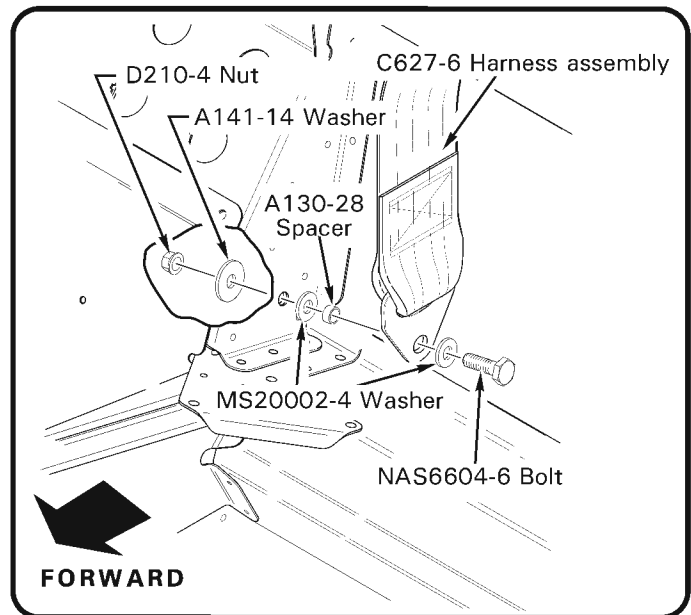

**FIGURE 1B**  
(harness installation, inboard; typical RH and LH sides)

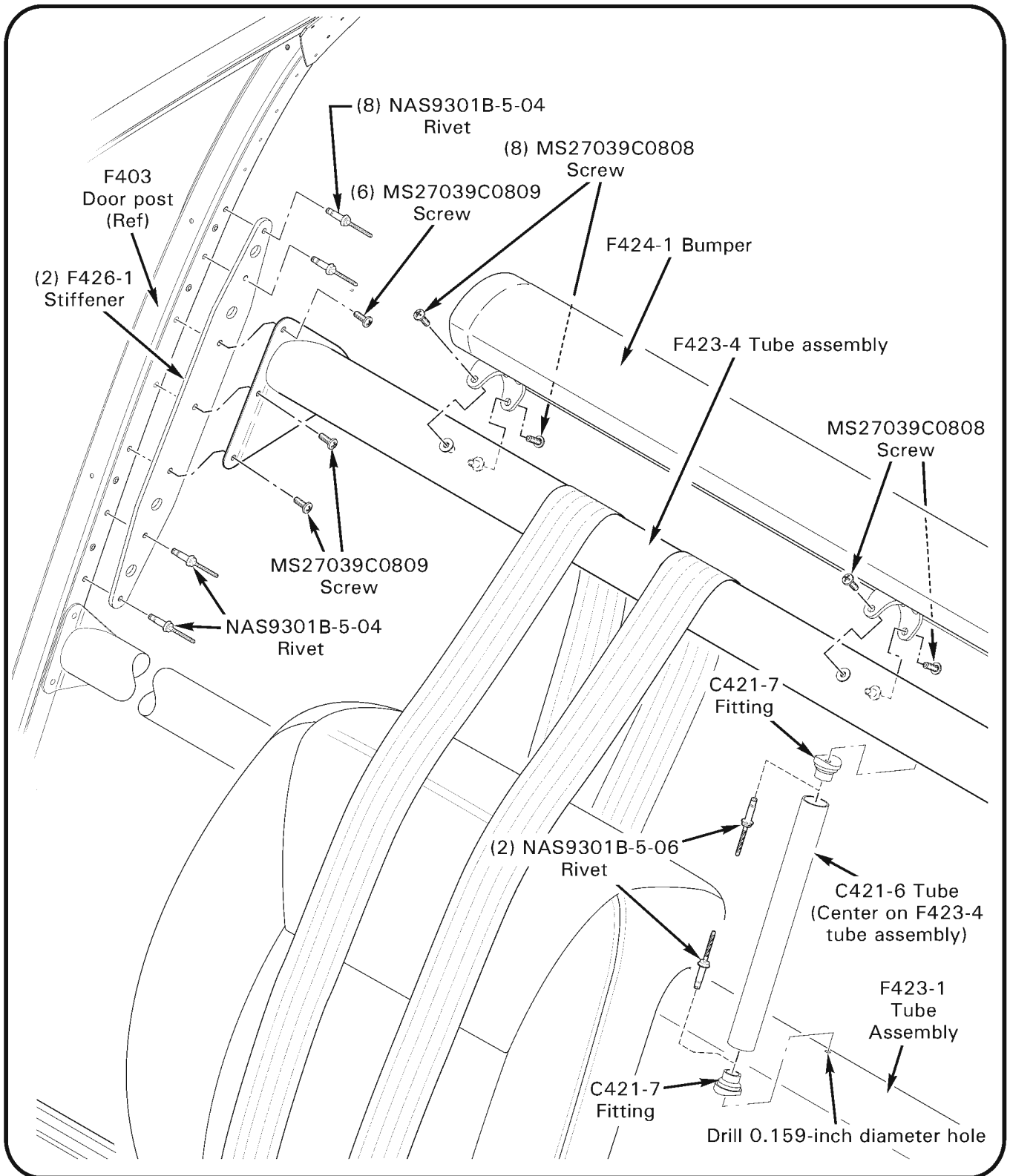

**FIGURE 2**  
(typical RH and LH sides)

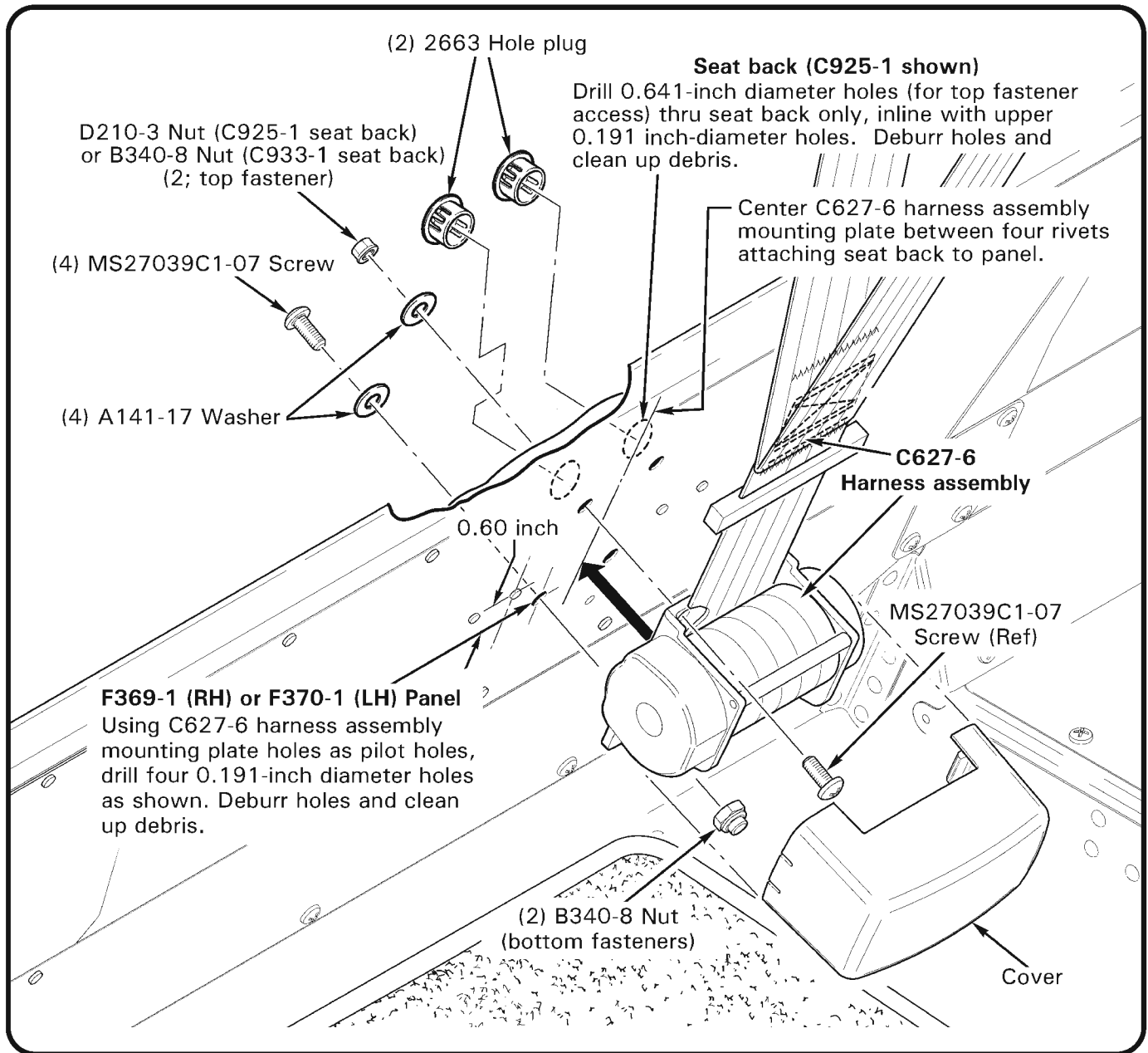

**FIGURE 3**  
(typical RH and LH sides)

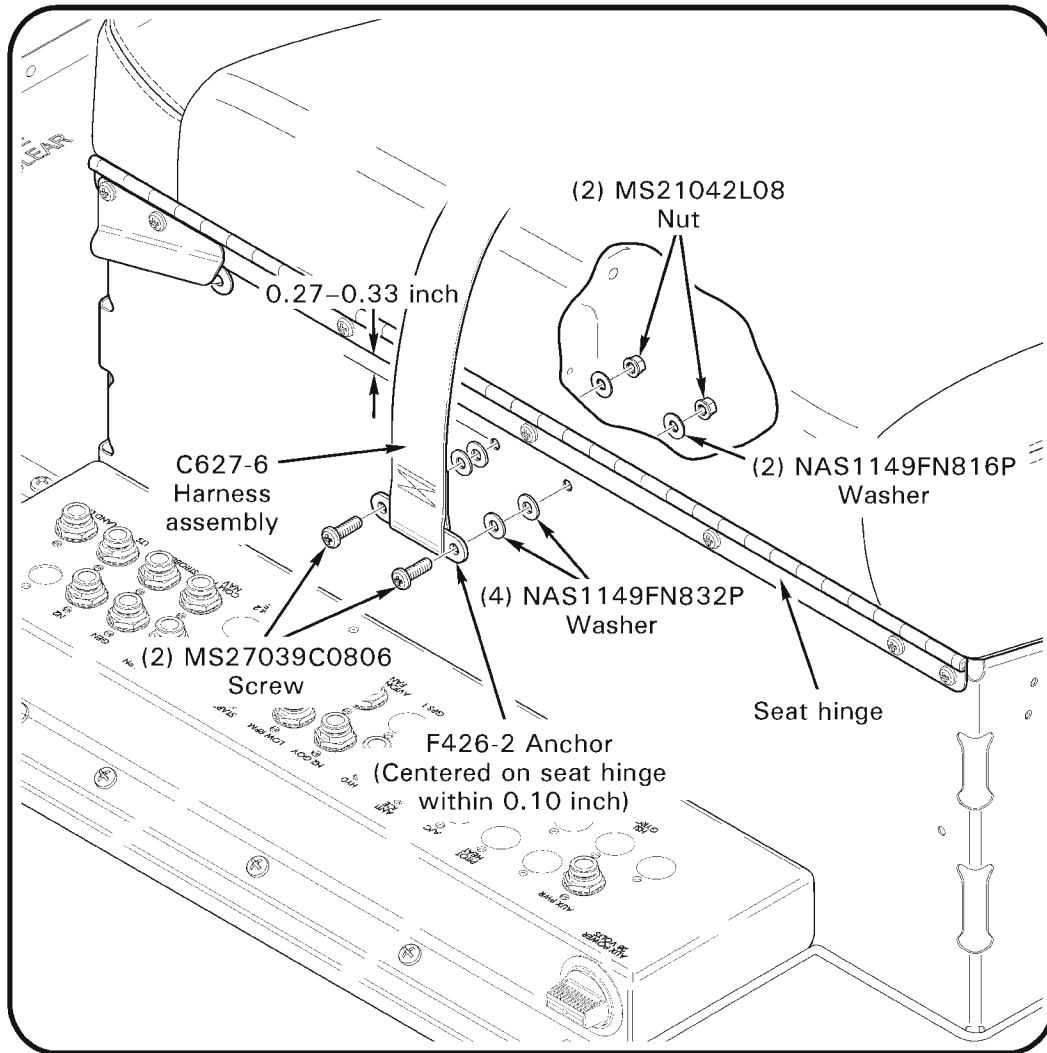

**FIGURE 4**  
(view looking aft; LH side)

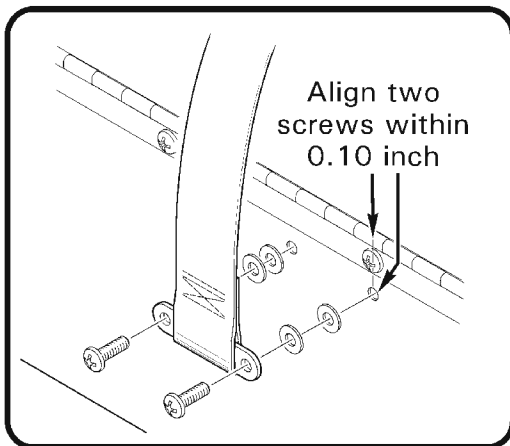

**FIGURE 4A**  
(RH side; same as Figure 4 except as shown)

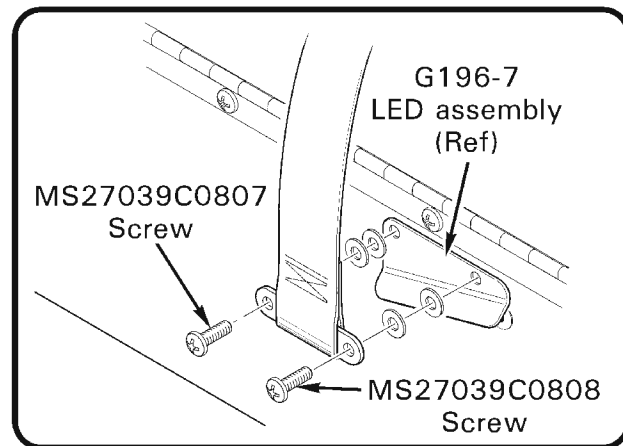

**FIGURE 4B**  
(LH side with LED assembly)