

CHAPTER 79
ENGINE OIL SYSTEM

<i>Figure</i>	<i>Title</i>	<i>Page</i>
79-1	Oil Cooler Installation	79.0
79-3	Oil System	79.2
79-7	Oil System	79.6
79-9	Oil Filter Installation	79.8
79-11	Oil Filter Installation	79.10

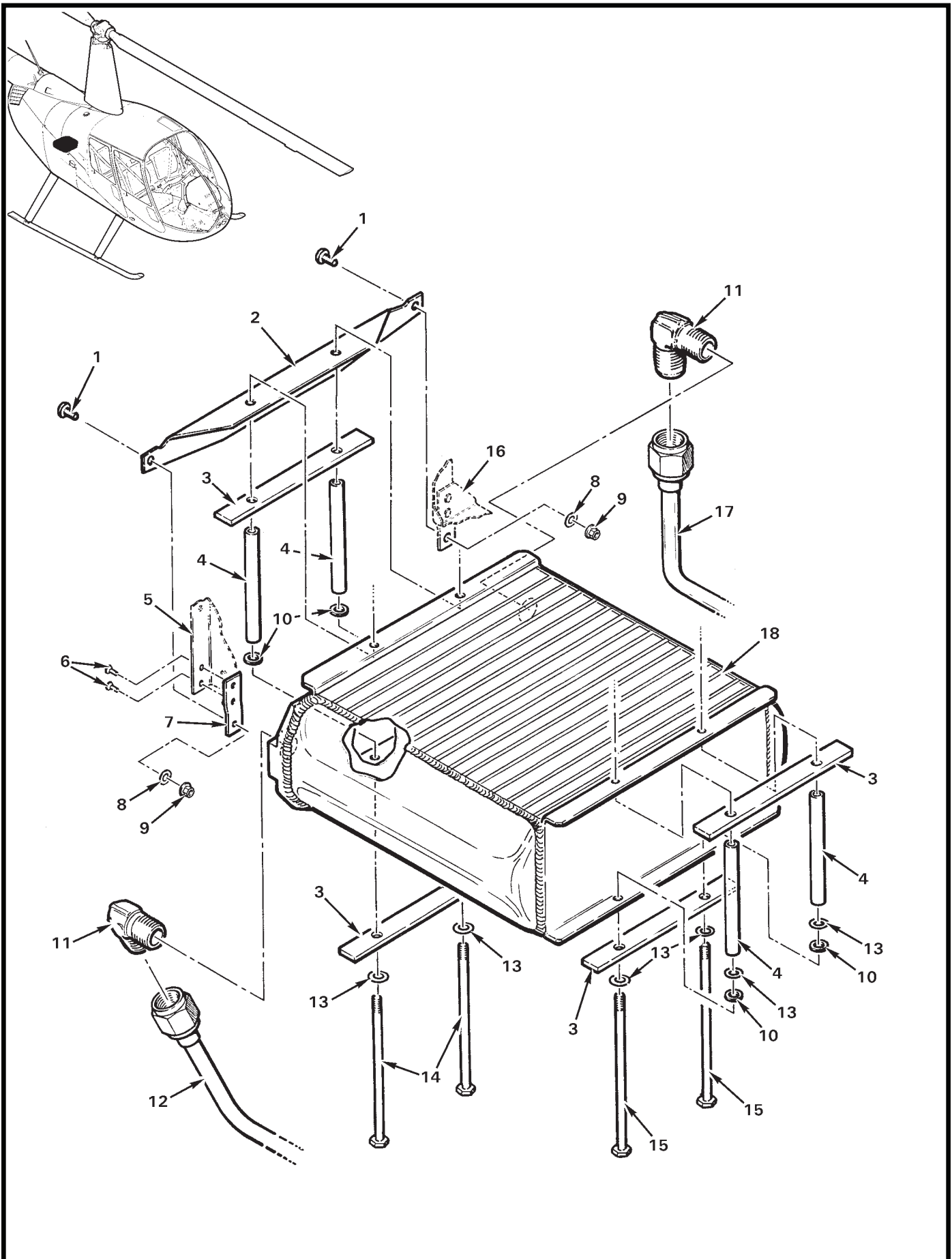

FIGURE AND INDEX NUMBER	PART NUMBER	DESCRIPTION	PARTS AVAIL	QTY PER ASSY
LARGE OIL COOLER INSTALLATION				
79-1-1	MS27039C0806	Screw	X	2
2	D636-1	Support	X	1
3	A668-1	Doubler	X	4
4	A130-49	Spacer	X	4
5	C305-8	Panel Assembly (Ref, see Figure 71-41)		
6	NAS1097AD4-4S	Rivet	X	2
7	D664-2	Strap	X	1
8	NAS1149FN816P	Washer	X	2
9	MS21042L08	Nut	X	2
10	NAS1149F0363P	Washer	X	4
11	MS20822-8	Elbow (install using item 19 on threads)	X	2
12	A723-15	Oil Line (outboard, helicopter-right; for ships with D723-1 oil filter adapter assembly, see Figure 79-9)	X	1
	A723-17	Oil Line (outboard, helicopter-right; for ships with 54J21208* oil filter adapter assembly; see Figure 79-11)	X	1
13	NAS1149F0332P	Washer	X	4
14	NAS6603-60	Bolt (or AN3-41A)	X	2
15	NAS6603-68	Bolt (or AN3-44A)	X	2
16	C309-5	Panel Assembly – RH Inboard (Ref, see Figure 71-41)		
17	A723-16	Oil Line (inboard, helicopter-right)	X	1
18	C649-2**	Oil Cooler – Large	X	1
19	B270-6	Sealant	X	A/R

20	KI-147	Large Oil Cooler Retrofit Kit (Replaces item 7 from Figure 79-3. Includes items 2, 6, 7, 12 [A723-15], 17 thru 19, and 21 thru 24.)	X	1
21	A701-1	Foil Tape (5-foot length)	X	1
22	C309-5	Panel Assembly – RH	X	1
23	C487-1	Retainer (straight)	X	1
24	C487-2	Retainer (bent)	X	1

NOTES * Lycoming part no.
 ** Width of oil cooler is 8.43-inches from bolt hole centerline to bolt hole center line.

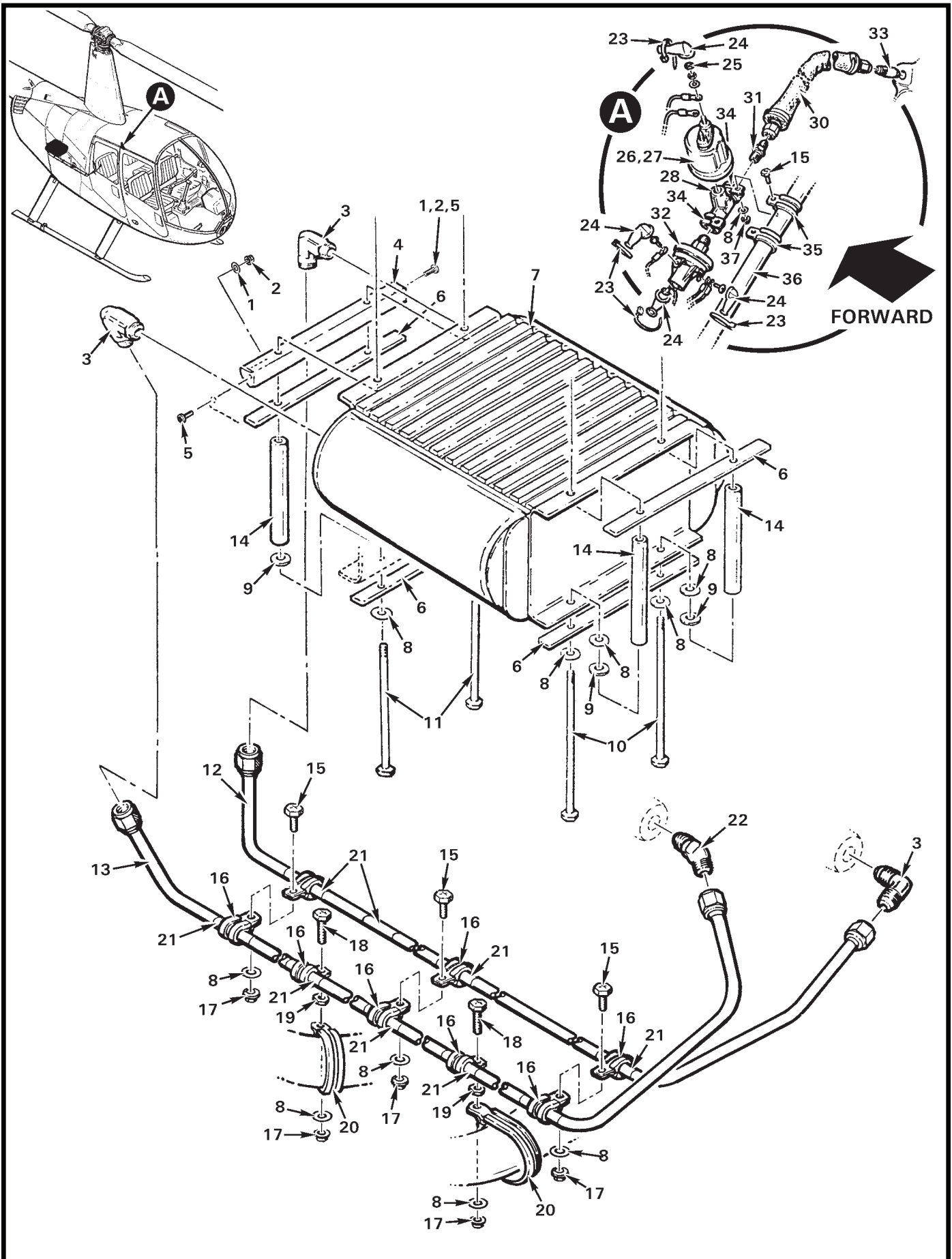

FIGURE AND INDEX NUMBER	PART NUMBER	DESCRIPTION	PARTS AVAIL	QTY PER ASSY
OIL SYSTEM*				
79-3-1	NAS1149FN816P	Washer	X	2
2	MS21042L08	Nut	X	2
3	MS20822-8	Elbow (use item 29 on threads)	X	3
4	C636-1	Support	X	1
5	MS27039C0806	Screw	X	2
6	A668-1	Doubler	X	4
7	C649-1 *	Oil Cooler – Small (To replace, order KI-147 Large Oil Cooler Retrofit Kit. See Figure 79-1.)	X	1
8	NAS1149F0332P	Washer	X	6
9	NAS1149F0363P	Washer	X	4
10	NAS6603-60	Bolt	X	2
11	NAS6603-68	Bolt	X	2
12	A723-10	Oil Line	O	1
13	A723-9	Oil Line	O	1
14	A130-49	Spacer	X	4
15	AN3-3A	Bolt	X	7
16	MS21919WCH8	Clamp	X	8
17	MS21042L3	Nut	X	5
18	NAS428-3A6	Bolt	X	2
19	AN345-10	Nut	X	2
20	MS21919WDG28	Clamp (forward and aft intake tubes)	X	2
21	B158-212	Heat Shrink (9 places)	X	A/R
22	MS20823-8	Elbow (use item 29 on threads)	X	1
23	MS3367-4-9	Ty-Rap	X	5
24	MS25171-1S	Nipple	X	5
25	B330-6	Palnut	X	2
26	A058-3	Oil Pressure Sender and Line Assembly (Incl items 27 thru 32)	X	1
27	B308-1	Oil Pressure Sender	X	1
28	AN917-1D	Tee (use item 29 on threads)	X	1
29	B270-6	Sealant (4-oz tube)	X	A/R
30	B283-1	Hose Assembly	X	1
31	AN816-3D	Nipple	X	1
32	B426-1	Oil Pressure Switch (Hobbs part no. 76083-30)	X	1
33	A571-1	Fitting Assembly (install using item 29)	X	1
34	MS21919WDG9	Clamp	X	2

NOTES * Width of oil cooler is 7.94-inches from bolt hole centerline to bolt hole center line.

Continues

FIGURE AND INDEX NUMBER	PART NUMBER	DESCRIPTION	PARTS AVAIL	QTY PER ASSY
OIL SYSTEM (Cont'd)				
79-3-35 36	MS21919WDG14 C046-1	Clamp Lower Frame Assembly, LH (Ref; replace with C046-21 and D046-2, see Figure 53-23)	X	2
37	D210-3	Nut	X	2

NOTES

Intentionally Blank

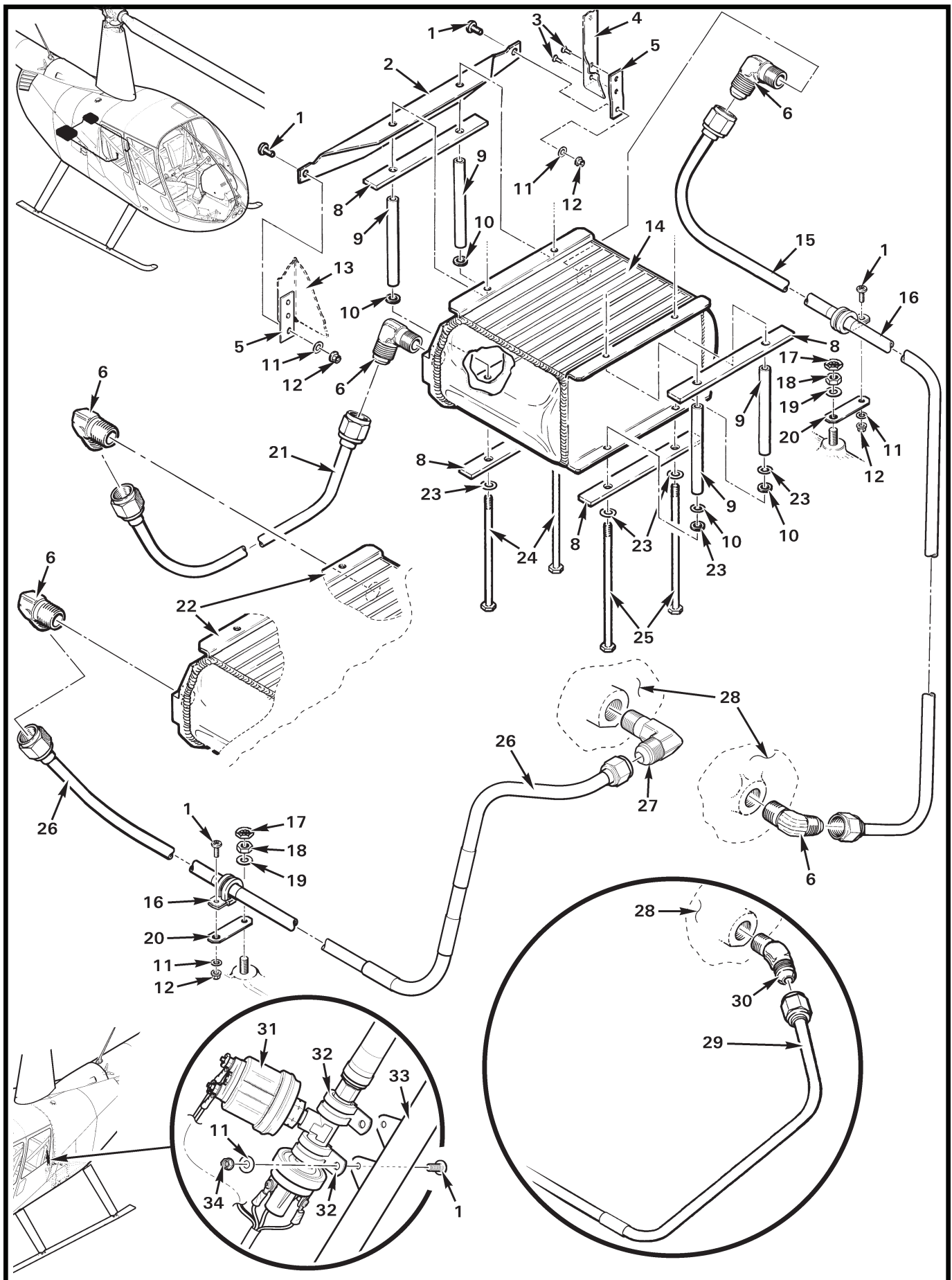

FIGURE AND INDEX NUMBER	PART NUMBER	DESCRIPTION	PARTS AVAIL	QTY PER ASSY
OIL SYSTEM*				
79-7-1	MS27039C0806	Screw	X	6
2	D636-2	Support	X	1
3	NAS1097AD4	Rivet	X	2
4	D380-1	Panel (Ref, see also Figure 71-37)		
5	D664-2	Strap	X	2
6	A880-668	Elbow (install using item 7)	X	5
7	B270-6	Sealant	X	A/R
8	A668-1	Doubler	X	4
9	A130-49	Spacer	X	4
10	NAS1149F0363P	Washer	X	4
11	NAS1149FN816P	Washer	X	6
12	MS21042L08	Nut	X	4
13	C310-4	Panel Assembly (Ref, see also Figure 71-37)		
14	C649-3	Oil Cooler (auxiliary)	X	1
15	D753-2	Line Assembly (helicopter-left)	X	1
16	NAS1715C8SW	Clamp	X	2
17	B330-12	Palnut	X	2
18	STD-1411	Nut	X	2
19	NAS1149F0432P	Washer	X	2
20	C357-3	Clip	X	2
21	D753-1	Line Assembly (cooler to cooler)	X	1
22	C649-2	Oil Cooler – Large (main; Ref, see also Figure 79-1)		
23	NAS1149F0332P	Washer	X	4
24	AN3-41A	Bolt (or NAS6603-60)	X	2
25	AN3-44A	Bolt (or NAS6603-68)	X	2
26	A723-18	Line Assembly (outboard, helicopter-right)	X	1
27	A457-21	Elbow (for use with item 26; install using item 7)	X	1
28	C145-2	Engine Assembly (Ref, IO-540-AE1A5)		
29	A723-15	Line Assembly (outboard, helicopter-right)	O	1
30	MS20823-8	Elbow (for use with item 29; install using item 7)	X	1
31	A058-3	Sender Assembly	X	1
32	MS21919WDG9	Clamp	X	2
33	C046	Lower Frame (Ref)		
34	MS21042L08	Nut	X	2

NOTES * Ship S/N 10001 thru 29999.

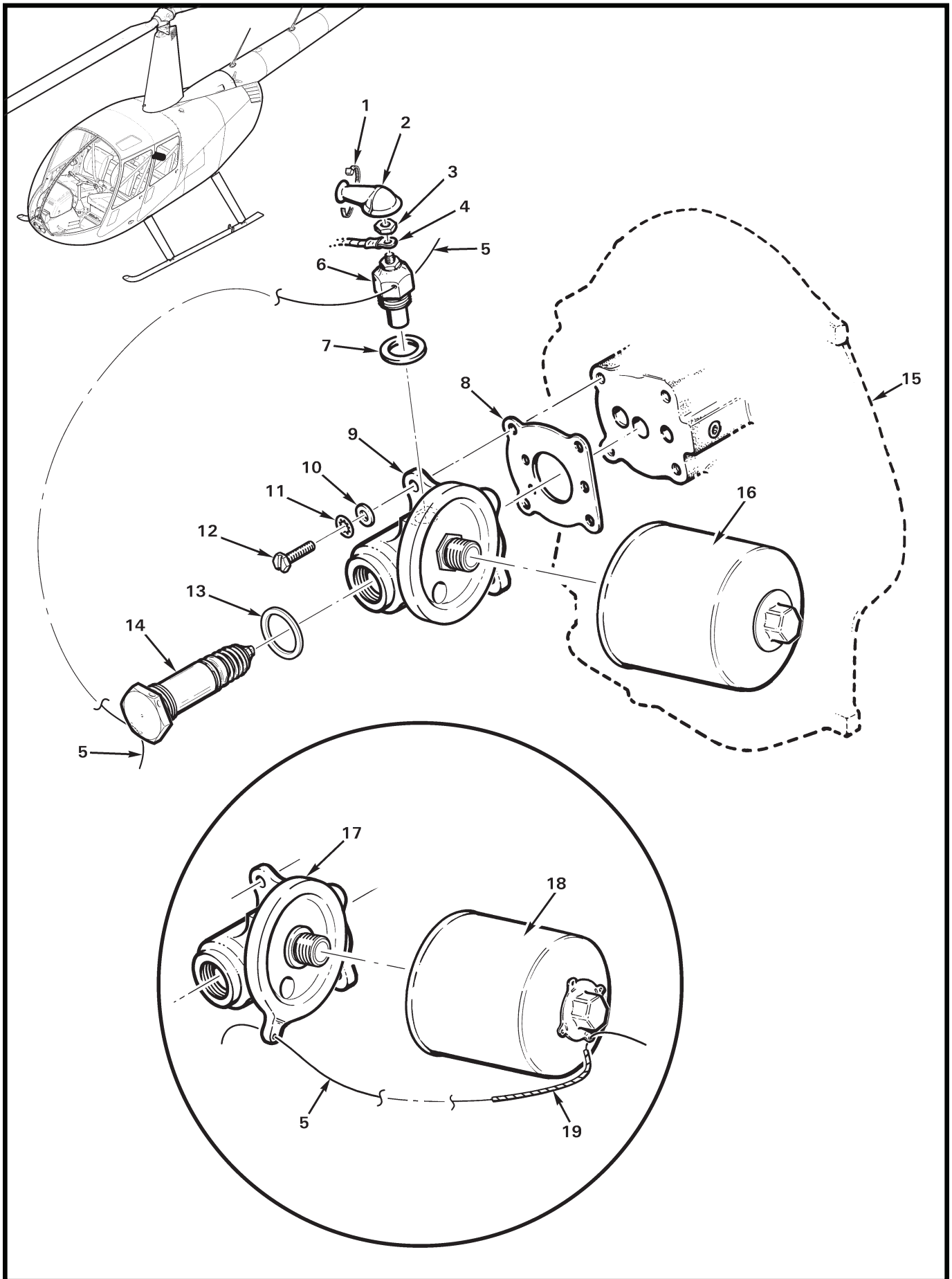

FIGURE AND INDEX NUMBER	PART NUMBER	DESCRIPTION	PARTS AVAIL	QTY PER ASSY
OIL FILTER INSTALLATION				
79-9-1	MS3367-4-9	Ty-rap	X	1
2	MS25171-1S	Nipple	X	1
3	—	Nut (Ref)		
4	C049-8	Harness Assembly	X	1
5	MS20995C32	0.032-in. dia. Safety Wire	X	A/R
6	A760	Oil Temperature Sender (Ref; see also Figure 96-49)		
7	15-724	Gasket (Ref; see also Figure 96-49)		
8	61173*	Gasket – Oil Filter Adapter	X	1
9	D723-1	Adapter – Oil Filter (revision “H” and subsequent)	X	1
10	STD-8*	Washer	X	4
11	STD-160*	Lockwasher	X	4
12	STD-1856*	Screw	X	4
13	76510*	Gasket	X	1
14	53E22144*	Thermostatic Oil Cooler Bypass Valve	X	1
15	—	Accessory Housing (Ref)		
16	B123-2	Oil Filter	X	1
17	D723-1	Adapter – Oil Filter (Revision “G” and prior, provisions for safety wire. Ref; no longer available.)		
18	B123-1	Oil Filter (provision for safety wire)	O	1
19	B161-102	Spirap	X	A/R
* * *				
20	KI-163**	Full-Flow Oil Filter Installation Kit (Incl items 8, 9, 11, 13, and 16)	X	1

NOTES * Lycoming part no.
 ** For R44s without previously installed oil filter.

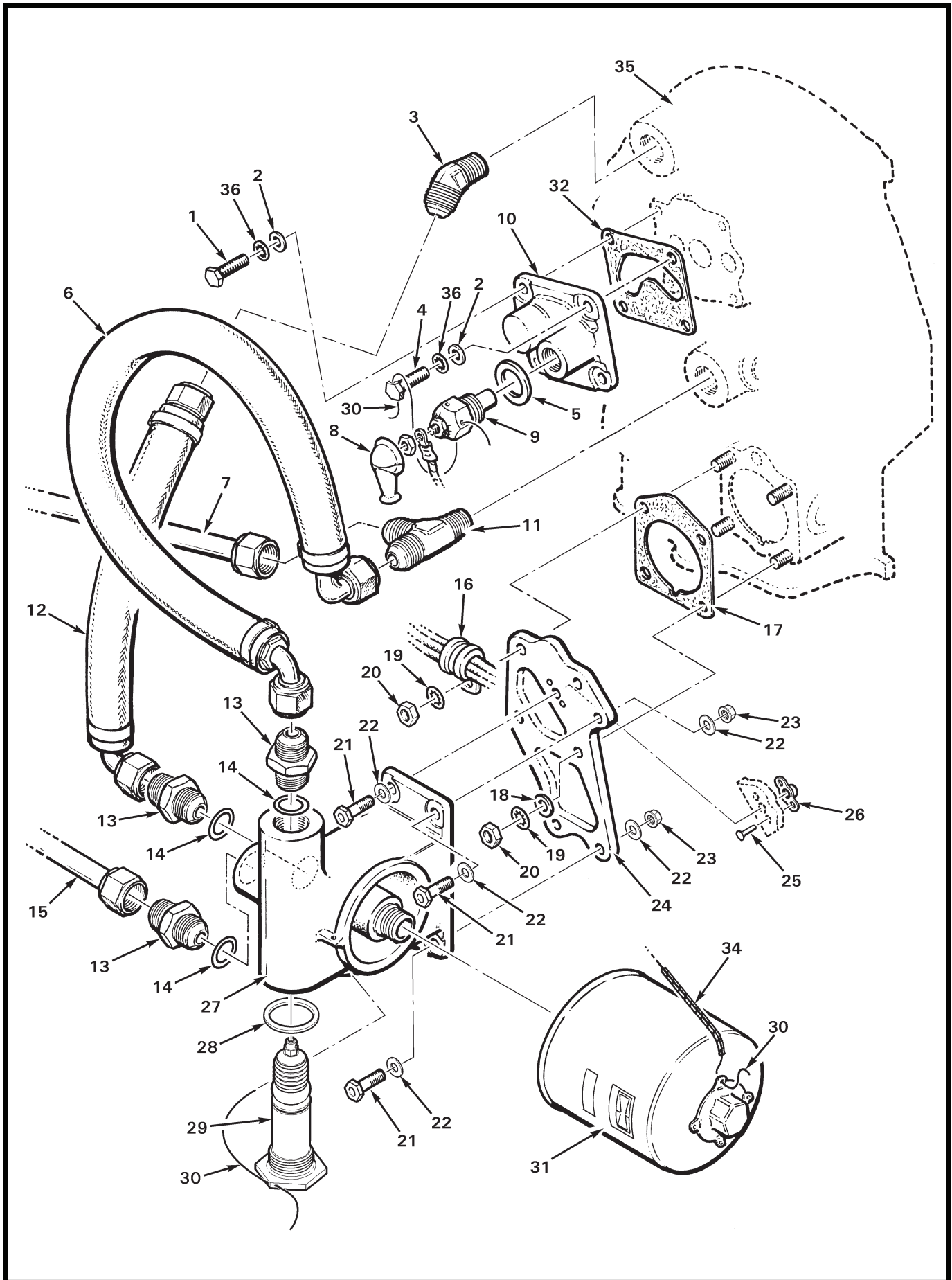

FIGURE AND INDEX NUMBER	PART NUMBER	DESCRIPTION	PARTS AVAIL	QTY PER ASSY
		OIL FILTER INSTALLATION*		
79-11-1	LW-25-0.94**	Bolt (0.25"-20 x 0.94 in. length)	X	3
2	STD-8**	Washer	X	4
3	MS20823-8	Elbow - 45° (install using item 33)	X	1
4	LW-25H-1.00**	Bolt (0.25"-20 x 1.00 in. length, drilled head)	X	1
5	15-724	Gasket	X	1
6	B283-5	Hose Assembly***	O	1
7	A723-10	Oil Line Assembly*** (return from cooler; use with C649-1 small oil cooler. See also Figure 79-1.)	O	1
	A723-16	Oil Line Assembly (return from cooler; use with C649-2 large oil cooler. See also Figure 79-1.)	X	1
8	MS25171-1S	Nipple	X	1
9	A760-1	Oil Temperature Sender (includes nuts and item 5)	X	1
10	21M21643**	Port Cover - Oil Screen	O	1
11	A880-1168	Tee (install using item 33)	X	1
12	B283-4	Hose Assembly***	O	1
13	A880-968	Union	X	3
14	MS28778-8	Packing	X	3
15	A723-13	Oil Line Assembly*** (out to cooler; use with C649-1 small oil cooler and item 27. See also Figure 79-1.)	O	1
	A723-17	Oil Line Assembly*** (out to cooler; use with C649-2 large oil cooler and item 27. See also Figure 79-1.)	O	1
16	MS21333-113	Clamp	X	1
17	69551**	Gasket	X	1
18	STD-35**	Washer (Ref, supplied with engine)	X	3
19	STD-475**	Washer (Ref, internal teeth, one-time use)	X	4
20	STD-1410**	Nut (Ref, supplied with engine)	X	4
21	NAS6604-8	Bolt	X	4
22	NAS1149F0432P	Washer	X	7
23	D210-4	Nut	X	3
24	B354-1	Plate Assembly (Incl items 25 and 26)	X	1
25	MS20426AD4	Rivet	X	2
26	MS21075L4E	Nutplate	X	1
27	54J21208**	Oil Filter Adapter Assembly***	O	1

NOTES * Ship S/N 1150 and prior.
 ** Lycoming part no.
 *** Order KI-163 Full-Flow Oil Filter Installation Kit; see Figure 79-9.

Continues

FIGURE AND INDEX NUMBER	PART NUMBER	DESCRIPTION	PARTS AVAIL	QTY PER ASSY
OIL FILTER INSTALLATION* (Cont'd)				
79-11-28	06E19769-0.63**	Gasket	X	1
29	53E22144**	Bypass Valve Assembly - Thermostatic Oil Cooler	X	1
30	MS20995C32	0.032-in. dia. Safety Wire	X	A/R
31	CH48103-1	Oil Filter (Champion part no.; alternate part no. CH48103)	X	1
32	06B21644**	Gasket	X	1
33	B270-6	Sealant (4-oz. tube)	X	A/R
34	B161-102	Spirap (0.125 in. dia.)	X	A/R
35	21C21539-02**	Housing - Accessory (Ref)		
36	STD-160**	Lockwasher	X	4

NOTES * Ship S/N 1150 and prior.
 ** Lycoming part no.