

CHAPTER 62

MAIN ROTOR

<i>Figure</i>	<i>Title</i>	<i>Page</i>
62-1	Main Rotor Blade Assembly	62.0
62-3	Main Rotor Blade Assembly	62.2
62-7	Main Rotor Hub Installation	62.6

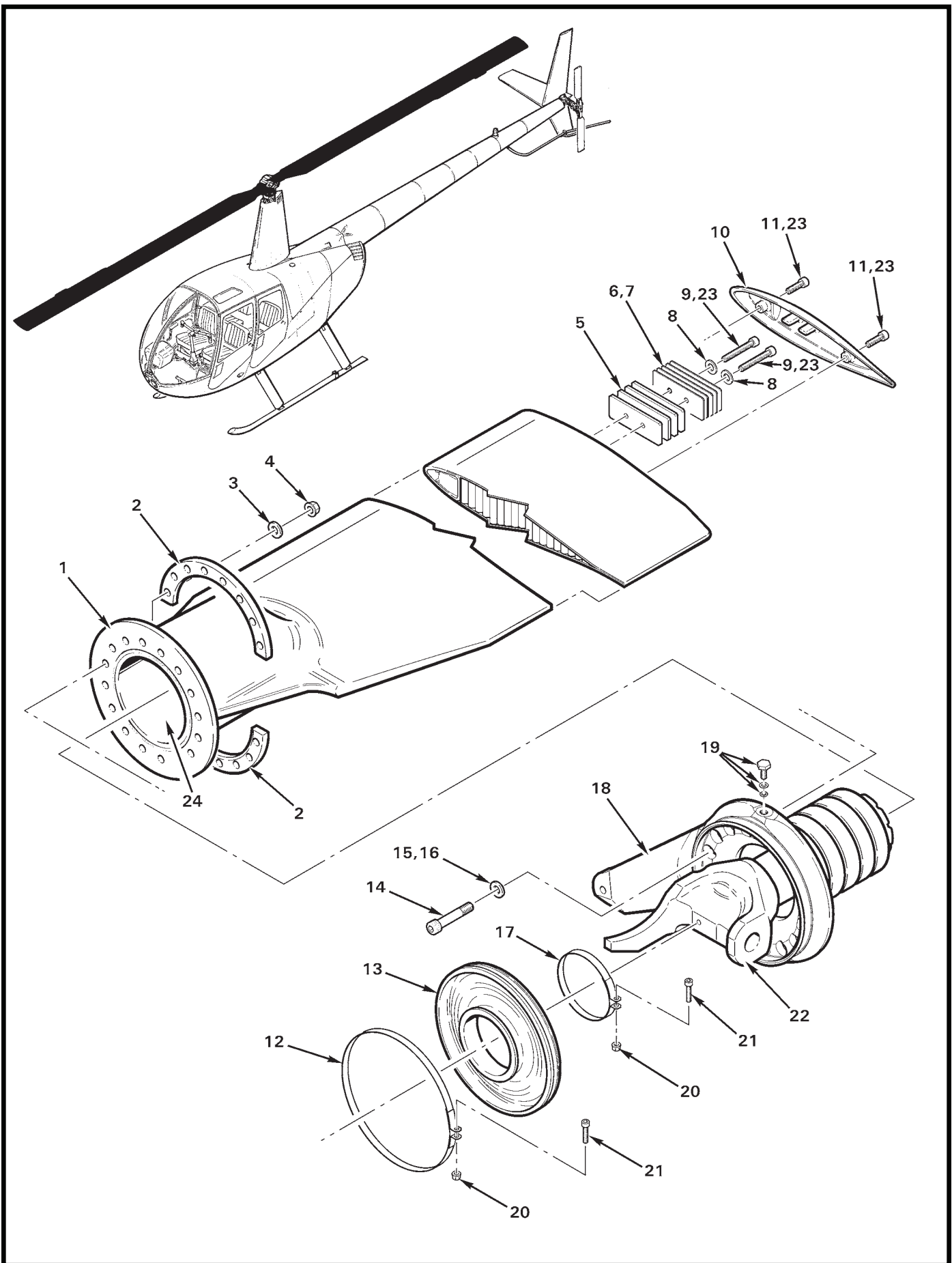

FIGURE AND INDEX NUMBER	PART NUMBER	DESCRIPTION	PARTS AVAIL	QTY PER ASSY
		MAIN ROTOR BLADE ASSEMBLY*		
62-1-1	C005-12**	Main Rotor Blade and Spindle Assembly – Extended Tab (Incl items 2 thru 4, 14 thru 16, 18, 19, and 24)	X	2
	C005-12R	Main Rotor Blade and Spindle Assembly (Two blade set, overhaul exchange; R9593 core deposit req'd. Includes R5352 shipping crate.)	X	1
	C016-7***	Blade Assembly – Extended Tab	O	1
2	C253-2	Spacer (eight holes)	O	2
3	NAS1149F0563P	Washer	X	16
4	D210-5	Nut	X	16
5	C298-4	Balance Strip (0.125 in. thick steel)	X	A/R
6	C298-3	Balance Strip (0.032 in. thick steel)	X	A/R
7	C298-2	Balance Strip (0.040 in. thick aluminum)	X	A/R
8	NAS1149F0332P	Washer (or NAS1149F0363P A/R for balance)	X	A/R
9	C722-3	Screw (install using item 23)	X	2
10	C300-3	Tip Cover (round)	X	1
11	NAS1351N3-12	Screw	X	2
12	C165-2	Clamp (Incl items 20 and 21)	X	1
13	C156-1	Boot (standard, black)	X	1
	C156-2	Boot (optional for sub-freezing operations, gray)	X	1
14	C722-1	Screw (install using item 23)	O	16
15	NAS1149F0563P	Washer (install using item 16, both sides)	X	16
16	B270-1	Sealant (2-oz tube)	X	A/R
17	C165-1	Clamp (Incl items 20 and 21)	X	1
18	C005-14	Spindle Assembly (Incl items 12, 13, 17, and 22)	O	1
	C157-3	Pitch Horn (Ref)		
19	B289-2	Bolt (includes washer and o-ring)	X	2
	—	Washer (teflon)	O	1
	MS29512-2	O-Ring	X	1
20	MS21042L08	Nut	X	1
21	NAS1352-08-12P	Screw	X	1
22	C158-1	Spindle (Ref)		
23	A257-9	Anti-Seize	X	A/R
24	A257-4	Oil (to fill blade housing)	X	A/R

NOTES * Aluminum skin blades; see Figure 99-23 for shipping crate.
 ** Refer to R44 SL-37 for installation requirements.
 *** Critical part; see R44 Maintenance Manual.

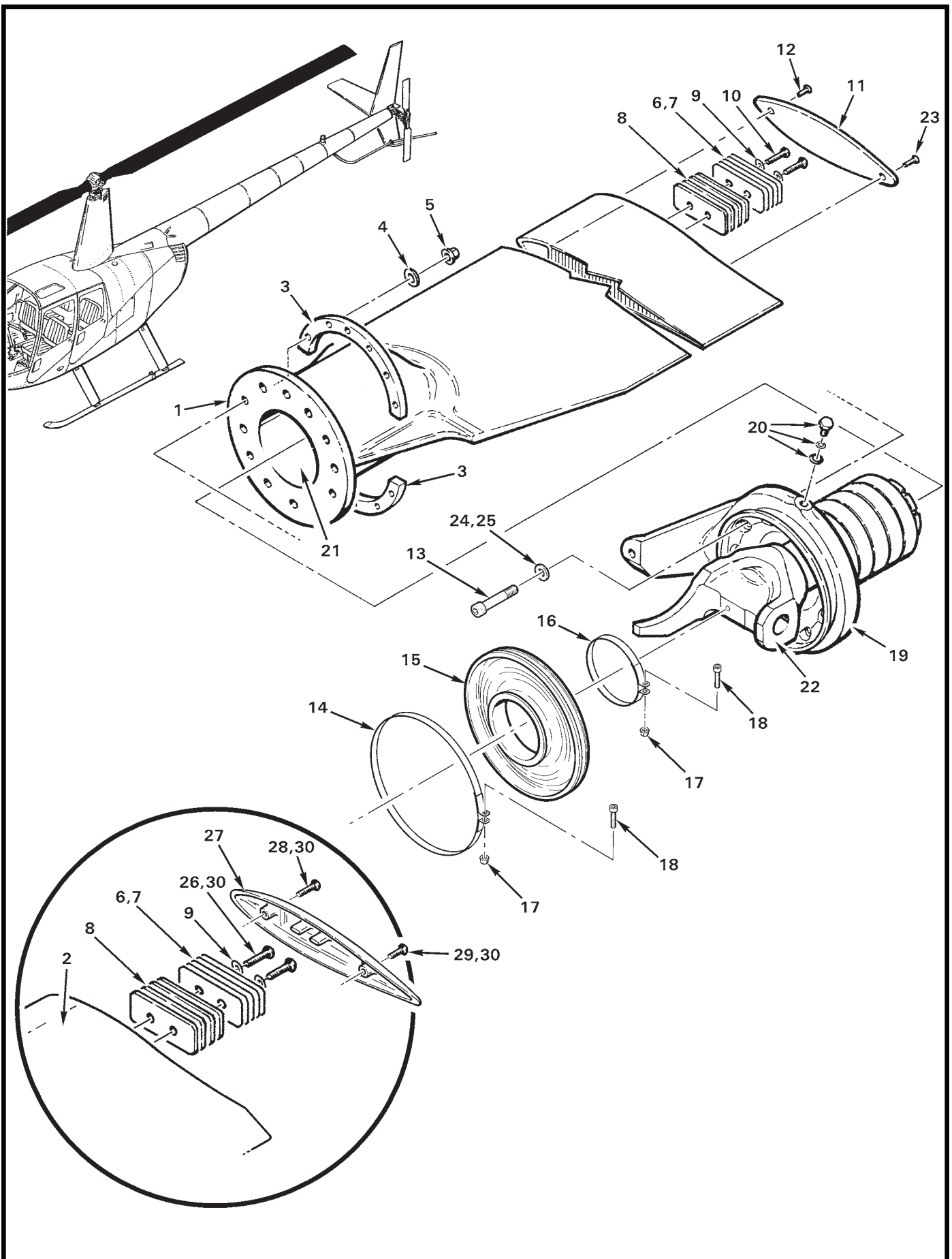

FIGURE AND INDEX NUMBER	PART NUMBER	DESCRIPTION	PARTS AVAIL	QTY PER ASSY
		MAIN ROTOR BLADE ASSEMBLY*		
62-3-1	C005-6**	Main Rotor Blade and Spindle Assembly – Constant Chord (Ref, no longer available. Superseded by C005-12 Main Rotor Blade and Spindle Assembly, see Figure 62-1.)		
	C016-2**	Blade Assembly – Constant Chord (Ref, remove from service per AD 2014-23-16)		
2	C005-8***	Main Rotor Blade and Spindle Assembly – Extended Tab (Ref, no longer available. Superseded by C005-12 Main Rotor Blade and Spindle Assembly, see Figure 62-1.)		
	C016-5***	Blade Assembly – Extended Tab (Ref, remove from service per AD 2014-23-16)		
3	C253-1	Spacer	O	2
4	NAS1149F0563P	Washer	X	12
5	D210-5	Nut	X	12
6	C298-2	Balance Strip (0.040 in. thick steel)	X	A/R
7	C298-3	Balance Strip (0.032 in. thick steel)	X	A/R
8	C298-4	Balance Strip (0.125 in. thick steel)	X	A/R
9	NAS1149F0332P	Washer (or NAS1149F0363P A/R for balance)	X	A/R
10	C722-3	Screw	X	2
11	C300-2	Tip Cover (flat)	X	1
12	MS24694-C54	Screw	X	1
13	C722-1	Screw	O	12
14	C165-2	Clamp Assembly (Incl items 17 and 18)	X	1
15	C156-2	Boot (gray)	X	1
	C156-1	Boot (black)	X	1
16	C165-1	Clamp Assembly (Incl items 17 and 18)	X	1
17	MS21042L08	Nut	X	1
18	NAS1352-08-12P	Screw	X	1
19	C005-9	Spindle Assembly (Incl items 14 thru 16, and 22)	O	1
	C157-3	Pitch Horn (Ref, 16 hole)	O	1
	C157-2	Pitch Horn (Ref, 12 hole)	O	1
20	B289-2	Bolt (includes washer and o-ring)	X	2
	MS29512-2	O-Ring	X	1
21	A257-4	Oil (to fill blade housing)	X	A/R

NOTES * Stainless steel skin blades; see Figure 99-23 for shipping crate.

** Ship S/N 0001 thru 9999.

*** Ship S/N 10001 and subsequent.

Continues

FIGURE AND INDEX NUMBER	PART NUMBER	DESCRIPTION	PARTS AVAIL	QTY PER ASSY
MAIN ROTOR BLADE ASSEMBLY* (Cont'd)				
62-3-22	C158-1	Spindle	O	1
23	MS24694-C51	Screw	X	1
24	NAS1149F0563P	Washer (install using item 25, both sides)	X	12
25	B270-1	Sealant (2-oz tube)	X	A/R
26	C722-3	Screw (install using item 30)	X	2
27	C300-3	Tip Cover (round)	X	1
28	NAS1351N3-16	Screw (install using item 30)	X	1
29	NAS1351N3-12	Screw (install using item 30)	X	1
30	A257-9	Anti-Seize	X	2

NOTES * Stainless steel skin blades; see Figure 99-23 for shipping crate.

Intentionally Blank

FIGURE AND INDEX NUMBER	PART NUMBER	DESCRIPTION	PARTS AVAIL	QTY PER ASSY
MAIN ROTOR HUB INSTALLATION				
62-7-1	NAS634-105*	Bolt (or MS21250-14105)	X	3
2	C152-1	Thrust Washer	X	6
3	C106-5	Journal-Bearing (length = 1.775 in.)	X	A/R
4	C106-7	Journal-Bearing (length = 1.284 in.)	X	A/R
5	C117-8	Shim-Washer (thickness = 0.012 in.)	X	A/R
6	C117-9	Shim-Washer (thickness = 0.015 in.)	X	A/R
7	C117-10	Shim-Washer (thickness = 0.020 in.)	X	A/R
8	C117-11	Shim-Washer (thickness = 0.025 in.)	X	A/R
9	C189-14*	Nut	X	3
10	MS24665-423	Cotter Pin	X	3
11	C005-4	Hub Assembly (Incl items 12 thru 15, and 26)	X	1
12	C154-1	Hub (Ref, does not include items 14 and 15)	O	1
13	A654-18	Decal "LEVEL HERE"	X	1
14	C648-3**	Bearing (teeter, black)	X	2
15	C648-1**	Bearing (coning, brown)	X	4
16	C251-2	Shaft – Main Rotor (Ref)		
17	C252-1	Spacer – Main Rotor Hub (Ref)	O	1
18	NAS6608-60	Bolt	X	1
19	NAS1149F0832P***	Washer	X	2
20	C150-1	Droop Stop	X	2
21	D151-2	Stop (Replaces D151-1. Use only with D226-2 bracket.) . . .	X	2
22	D226-2	Bracket (Replaces D226-1. Use only with D151-2 stop.) . . .	X	2
23	D210-8	Nut	X	1
24	B330-24	Palnut	X	1
25	C005-12	Blade and Spindle Assembly (Ref, see Figure 62-1)		
26	A651-1	Data Plate (Ref)		
27	A257-9	Anti-seize	X	A/R

NOTES * Install using item 27 on threads.
 ** Requires MT329-6 and MT643-1 tools.
 *** May use item 27 on washer under nut to prevent rotation of item 22 as torque is applied.

Intentionally Blank