

**CHAPTER 23****STANDARD PRACTICES**

<u>Section</u>	<u>Title</u>	<u>Page</u>
23-10	Cleaning . . . . .	23.1
23-20	Lubrication . . . . .	23.3
23-30	Torque Requirements . . . . .	23.5
23-31	Torque Stripe . . . . .	23.7
23-32	Standard Torques . . . . .	23.8
23-33	Special Torques . . . . .	23.9
23-34	Push-Pull Tube Rod End Adjustment . . . . .	23.13
23-35	D210-series Nuts on Critical Fasteners . . . . .	23.13
23-36	A880 Flared Tube Components . . . . .	23.14
23-40	Non-Destructive Testing . . . . .	23.26
23-41	Magnetic Particle Inspection . . . . .	23.26
23-42	Fluorescent Penetrant Inspection . . . . .	23.27
23-50	Corrosion Control . . . . .	23.27
23-51	Conversion Coat – Aluminum . . . . .	23.27
23-60	Priming and Painting . . . . .	23.28
23-70	Approved Materials . . . . .	23.31
23-71	Paint Strippers . . . . .	23.31
23-72	Solvents and Cleaners . . . . .	23.31
23-73	Fillers and Putty . . . . .	23.32
23-74	Torque Seal . . . . .	23.32
23-75	Primers . . . . .	23.33
23-76	Powder Coat . . . . .	23.34
23-77	Paints . . . . .	23.36
23-78	Lubricants . . . . .	23.39
23-79	Adhesives and Sealants . . . . .	23.40
23-80	Miscellaneous Practices . . . . .	23.42
23-81	Part Interchangeability . . . . .	23.42
23-82	Thermal Fitting Parts . . . . .	23.42
23-83	Replacement Component Identification (Data) Plates . . . . .	23.43
23-84	Crimp Inspection . . . . .	23.43
23-85	Storage Limits . . . . .	23.44
23-86	B526 Screws and B527-08 Washers . . . . .	23.44

Intentionally Blank

## CHAPTER 23

## STANDARD PRACTICES

23-10 Cleaning**WARNING**

Review appropriate Safety Data Sheet (SDS) when working in proximity to hazardous materials. Specific recommendations for use of personal protective equipment are located in the SDS.

**A. Cleaning Exterior Surfaces****CAUTION**

Refer to § 23-10 Part B for cleaning windshield and windows.

**CAUTION**

Never use high-pressure spray to clean helicopter. Never blow compressed air into main or tail rotor blade tip drain holes, pitot tube, or static ports.

**CAUTION**

Wash helicopter exterior surfaces with mild soap and water. Harsh abrasives, alkaline soaps, or detergents can scratch painted or plastic surfaces, or cause corrosion of metal. Protect areas where cleaning solution could cause damage.

1. Rinse away loose dirt and debris from exterior surface with clean water.
2. Apply mild soap and clean warm water solution to exterior surface using a clean, soft cloth, sponge, or soft bristle brush. Use caution near antennas and sensitive equipment.
3. Remove oil and grease using a cloth wetted with aliphatic naphtha.
4. Rinse all surfaces thoroughly.
5. If desired, polish painted surfaces with a good quality automotive wax using soft cleaning cloths, or a chamois cloth, free of abrasive debris.

23-10 Cleaning (continued)**B. Cleaning Windshield and Windows**

1. Remove dirt, mud, and other loose particles from exterior surfaces with clean water.
2. Wash with mild soap and warm water or with aircraft plastic cleaner. Use a soft cloth or sponge in a straight back and forth motion. Do not rub harshly.
3. Remove oil and grease with a cloth moistened with isopropyl alcohol (rubbing alcohol) or aliphatic naphtha.

**CAUTION**

Do not use gasoline, other alcohols, benzene, carbon tetrachloride, thinner, acetone, or window (glass) cleaning sprays.

4. After cleaning plastic surfaces, apply a thin coat of hard polishing wax. Rub lightly with a soft cloth. Do not use a circular motion.
5. Scratches can be removed from acrylic windshields by rubbing with jeweler's rouge followed by hand polishing with commercial plastic polish. Use a figure eight motion with polishing. Polishing polycarbonate (optional, impact-resistant) windshields is not recommended as it may thin the protective hardcoat finish.

**C. Cleaning Seat Assemblies and Back Rests**

1. Vacuum and brush, then wipe with damp cloth. Dry immediately.
2. Soiled upholstery, except leather, may be cleaned with a good upholstery cleaner suitable for the material. Follow manufacturer's instructions. Avoid soaking or harsh rubbing.
3. Leather should be cleaned with saddle soap or a mild hard soap and water.

**D. Cleaning Carpet**

Remove loose dirt with a whisk broom or vacuum. For soiled spots and stains, use nonflammable dry cleaning liquid.

23-20 Lubrication**WARNING**

**Review appropriate Safety Data Sheet (SDS) when working in proximity to hazardous materials. Specific recommendations for use of personal protective equipment are located in the SDS.**

Most bearings are sealed or self-lubricated and do not require periodic lubrication. Bearings with scheduled lubrication intervals are listed in Table 1 (see Chapter 1).

Engine lubrication requirements are located in the R22 Pilot's Operating Handbook, the appropriate model Lycoming Operator's Manual, and Lycoming Service Instruction No. 1014 (current revision).

Main and tail gearboxes require servicing when indicated by sight gage level. Additionally, change gearbox oil and clean respective sight gage when oil becomes so dirty its level cannot be determined.

**WARNING**

**Use approved gearbox oils only (refer to § 22-10 Part C).**

When installing a new or overhauled gearbox, drain and flush gearbox after the first 4 hours of flight or first chip light, whichever occurs first. Thereafter, change gearbox oil at intervals listed in Table 1 (see Chapter 1).

**Given**

- Y = Unknown
- T = 135 in.-lb
- L = 10 in.
- A = 1.5 in.

**Symbols**

- Y = Torque wrench setting
- T = Torque applied to fastener
- L = Length of torque wrench
- A = Length of adapter

When using an adapter that lengthens torque wrench effective length, calculate torque wrench setting using the formula below:

**EXAMPLE**

$$\text{Solve for } Y = \frac{T \times L}{L + A} = \frac{135 \times 10}{10 + 1.5} = \frac{1350}{11.5} = 117.39$$

Set torque wrench to 117 in.-lb to torque fastener to 135 in.-lb.

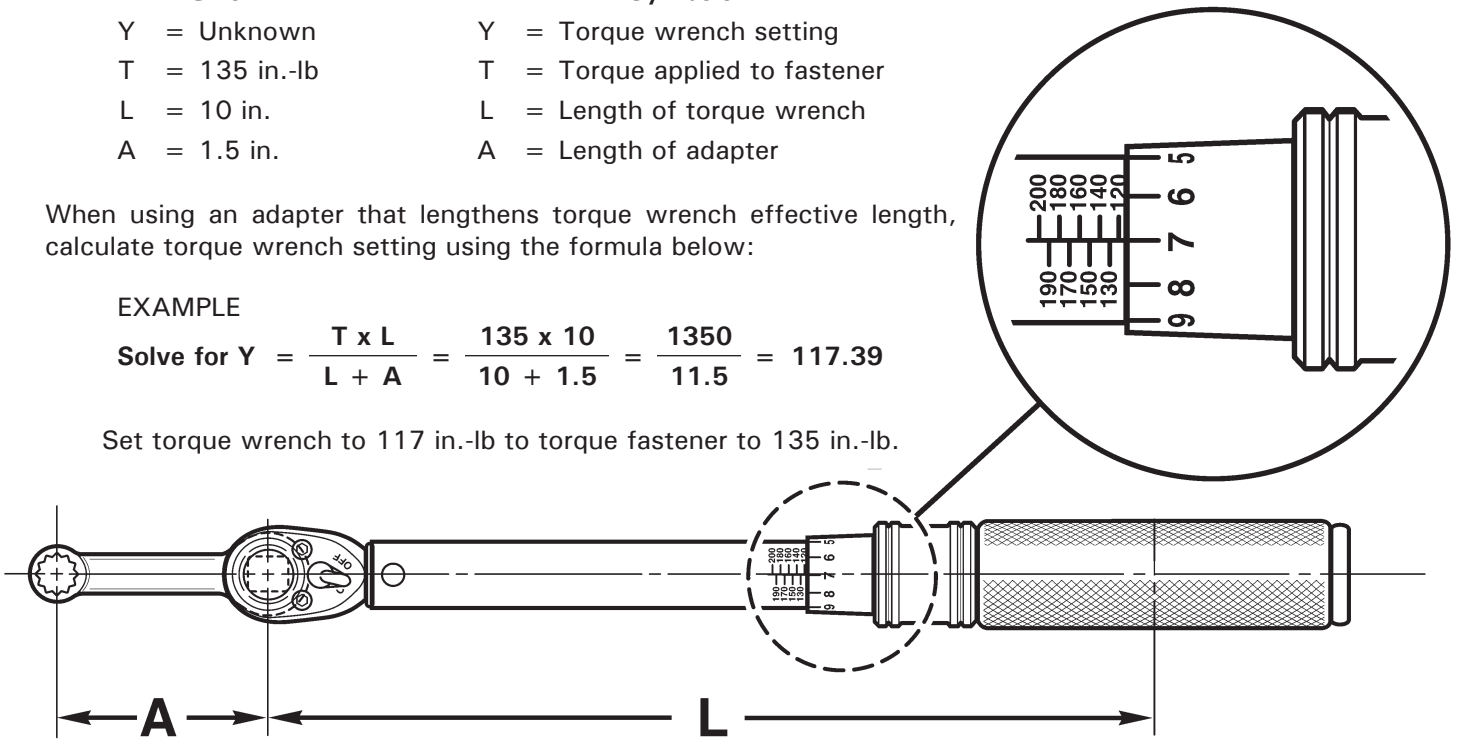

**FIGURE 23-1 LENGTHENING TORQUE WRENCH EFFECTIVE LENGTH**

**Given**

- Y = Unknown
- T = 135 in.-lb
- L = 10 in.
- A = 1.5 in.

**Symbols**

- Y = Torque wrench setting
- T = Torque applied to fastener
- L = Length of torque wrench
- A = Length of adapter

When using an adapter that shortens the torque wrench effective length, calculate torque wrench setting using the formula below:

**EXAMPLE**

$$\text{Solve for } Y = \frac{T \times L}{L - A} = \frac{135 \times 10}{10 - 1.5} = \frac{1350}{8.5} = 158.82$$

Set torque wrench to 159 in.-lb to torque fastener to 135 in.-lb.

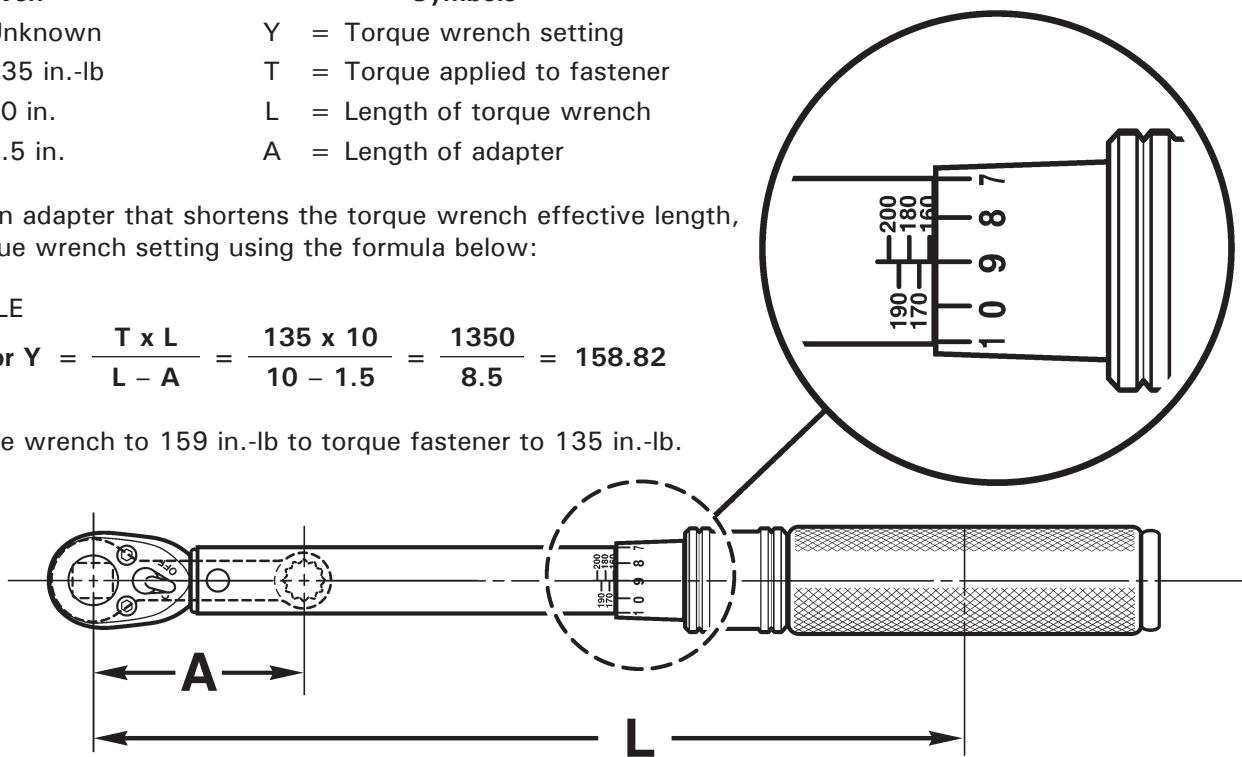

**FIGURE 23-2 SHORTENING TORQUE WRENCH EFFECTIVE LENGTH**

23-30 Torque Requirements

**A. Tool Calibration**

Dimensions and tolerances given in this manual are critical. Calibrate measuring tools per manufacturer’s recommendation at least once a year, when tool is dropped, misused, or calibration is suspect. Measuring tools include torque wrenches, micrometers, calipers, dial indicators, spring scales, protractors, and balancing equipment.

**WARNING**

**Proper torque is critical. Always use calibrated wrenches and undamaged, properly lubricated (where applicable) hardware. Ensure clamping surfaces are clean, and clamp only bare metal or wet-primed surfaces. Improper torque or dirty or painted clamping surfaces may result in loss of clamp-up, hardware or part damage, and premature failure.**

**B. Torque Value**

Torque fasteners to standard dry values listed in § 23-32 unless otherwise specified. If torque is applied by rotating bolt, increase torque value by 10% to account for higher friction at bolt head and shank.

For example, the torque wrench setting for an NAS6605 bolt used with an MS21075 nutplate is determined as follows:

NAS6605 bolt (5 indicates 5/16 inch size) dry torque per § 23-32	240 in.-lb
Add 10% because torque must be applied at bolt head	+ 24 in.-lb
Torque wrench setting	<u>264 in.-lb</u>

**C. Secondary Locking Mechanism**

A secondary locking mechanism is required on all critical fasteners. B330 stamped nuts (palnuts) serve as the secondary locking mechanism in most areas on the helicopter, and are torqued per § 23-32. Palnuts must be replaced when removed. The R22 Illustrated Parts Catalog (IPC) lists secondary locking mechanisms for specific fasteners.

23-30 Torque Requirements (continued)**D. Critical Fastener****CAUTION**

D210-series nuts, which supersede MS21042L-series and NAS1291-series nuts, are required on critical fasteners.

**WARNING**

**Assembly of flight controls is critical and requires inspection by a qualified person. If a second person is not available, RHC recommends the installer take a 5-minute break prior to inspecting flight control connections he has assembled.**

A critical fastener is one which, if removed or lost, would jeopardize safe operation of the helicopter. This includes joints in the primary control system, and non-fail-safe structural joints in the airframe, landing gear, and drive system.



23-30 Torque Requirements (continued)**E. Torque Requirements****CAUTION**

Never substitute AN bolts for NAS bolts. NAS bolts have higher tensile strength.

1. Any self-locking nut whose drag has deteriorated appreciably must be replaced. Damaged hardware must be replaced.
2. Bolt and nut are to be clean and dry except when assembly procedure specifies anti-seize or thread-locking compound.
3. If chattering or jerking occurs, disassemble and re-torque fastener.
4. If special adapters which change effective length of torque wrench are used, final torque value must be calculated using formulas in Figures 23-1 and 23-2.
5. Unless otherwise specified, proper thread engagement requires:
  - a. If palnut is not required, one to four threads exposed beyond primary nut.
  - b. If palnut is required, two to four threads exposed beyond primary nut.
  - c. For B526-8 screws, one to five threads exposed beyond primary nut.

**WARNING**

**Proper thread engagement ensures proper locking of fastener. Exceeding maximum thread exposure beyond primary nut may allow nut to seat against unthreaded shank, resulting in insufficient joint clamping.**

6. Refer to Part A. Torque wrenches must be calibrated annually, when dropped, or when a calibration error is suspected.

23-31 Torque Stripe**WARNING**

**Review appropriate Safety Data Sheet (SDS) when working in proximity to hazardous materials. Specific recommendations for use of personal protective equipment are located in the SDS.**

Refer to Figure 2-1. Lacquer-paint Torque Seal<sup>®</sup> is applied to all critical fasteners after palnut installation in a stripe ("torque stripe") extending from the fastener's exposed threads across both nuts and onto the component. Subsequent rotation of the nut or bolt can be detected visually. Position torque stripes for maximum visibility during preflight inspections. Approved Torque Seal<sup>®</sup> is listed in § 23-74.

23-32 Standard Torques

**NOTE**

1. Torque values are in inch-pounds unless otherwise specified.
2. Torque values include nut self-locking torque.
3. Increase torque values 10% if torqued at bolt head.
4. Wet indicates threads lubricated with A257-9 anti-seize.
5. For elbow and tee fittings which require alignment, torque to indicated value, then tighten to desired position.
6. Tolerance is  $\pm 10\%$  unless range is specified.
7. Unless otherwise specified, thread sizes 8-32 and smaller are not used for primary structure and do not require control of torques.

FASTENER SERIES	SIZE	EXAMPLE FASTENER	DRY TORQUE
NAS6603 thru NAS6608 Bolts NAS1303 thru NAS1308 Bolts NAS623 Screws NAS1351 & NAS1352 Screws NAS600 thru NAS606 Screws	10-32	NAS6603	50 in.-lb
	1/4-28	NAS6604	120 in.-lb
	5/16-24	NAS6605	240 in.-lb
	3/8-24	NAS6606	350 in.-lb
	7/16-20	NAS6607	665 in.-lb
	1/2-20	NAS6608	995 in.-lb
AN3 Bolts AN4 Bolts AN6 Bolts AN8 Bolts AN502 & AN503 Screws AN509 Screws AN525 Screws MS24694 Screws MS27039 Screws	10-32	AN3	37 in.-lb
	1/4-28	AN4	90 in.-lb
	3/8-24	AN6	280 in.-lb
	1/2-20	AN8	795 in.-lb
STAMPED NUTS (PALNUTS) Palnuts are to be used only once and replaced with new ones when removed.	10-32	B330-7 (MS27151-7)	6–15 in.-lb
	1/4-28	B330-13 (MS27151-13)	11–25 in.-lb
	5/16-24	B330-16 (MS27151-16)	20–40 in.-lb
	3/8-24	B330-19 (MS27151-19)	29–60 in.-lb
	7/16-20	B330-21 (MS27151-21)	42–85 in.-lb
	1/2-20	B330-24 (MS27151-24)	54–110 in.-lb
TAPERED PIPE THREADS	1/8-27	N/A	60 in.-lb
	1/4-18	N/A	85 in.-lb
	3/8-18	N/A	110 in.-lb
	1/2-14	N/A	160 in.-lb
	3/4-14	N/A	230 in.-lb
ROD END JAM NUTS (AN315 and AN316)	10-32	AN315-3	15 in.-lb
	1/4-28	AN316-4	40 in.-lb
	5/16-24	AN316-5	80 in.-lb
	3/8-24	AN316-6	110 in.-lb

23-33 Special Torques

These torques are non-standard and supersede those in § 23-32.

NOTE	
1.	Torque values are in inch-pounds unless otherwise specified.
2.	Torque values include nut self-locking torque.
3.	Increase torque values 10% if torqued at bolt head.
4.	Wet indicates threads lubricated with A257-9 anti-seize.
5.	For elbow and tee fittings which require alignment, torque to indicated value, then tighten to desired position.
6.	Tolerance is ± 10% unless range is specified.
7.	Unless otherwise specified, thread sizes 8-32 and smaller are not used for primary structure and do not require control of torques.

AREA	(QUANTITY) FASTENER	TORQUE
DRIVE SYSTEM	(1) AN320-15 nut (1 ½ inch socket) on A007-3 shaft assembly	183–233 ft-lb wet
	(1) AN320-18 nut (1 <sup>11</sup> / <sub>16</sub> inch socket) on A007-5 shaft assembly	340–400 ft-lb wet
	(6) NAS6606H23 or (6) NAS6606H24 bolts, lower sheave	300 in.-lb
EMPENNAGE	(4) NAS6603-2 & (4) NAS6603-5 bolts, vertical stabilizer attach	70 in.-lb
FANWHEEL	(1) AN320-15 or AN320-18 nut – see DRIVE SYSTEM	
	(8) or (12) NAS6603-3 or -6 bolts and D210-3 nuts, cone-to-fanwheel	70 in.-lb
	(6) NAS6605-12, -13, or -14 bolts, hub	300 in.-lb, and retorque after first engine run after installation
FUEL SYSTEM	(1) A457-15 bulkhead union and nut	285 in.-lb
	(1) A657-1 nut, fuel valve elbow-to-bulkhead union	120 in.-lb
	(1) A726-1 line assembly, bulkhead union-to-gascolator	285 in.-lb
	(1) A880-934, A880-964, or AN815-4D union, main tank, drain hose	145 in.-lb
	(1) A880-936, A880-966, or AN815-6D union, main tank, tank interconnect hose	200 in.-lb
	(1) A880-1004 or AN924-4D nut, main tank, drain valve	145 in.-lb
	(1) A880-1005 or AN924-5D nut, low-fuel warning switch	150 in.-lb
	(2) B254-3 strainer assembly, tank outlets	200 in.-lb wet
	(1) B283 hose assembly nuts, gascolator-to-carburetor	120 in.-lb
	(5) B289-1 bolts, fuel sender (torque in criss-cross pattern)	37 in.-lb
	(2) B330-5 palnut, fuel sender ground stud	9 in.-lb
	(2) B330-6 palnut, fuel sender center stud	11 in.-lb
	(1) C595-1 or D205-33 hose assembly nuts, tank interconnect	120 in.-lb
	(1) D205-32 hose assembly nuts, main tank-to-fuel valve	120 in.-lb
	(1) D205-34 hose assembly nuts, main tank drain	60 in.-lb
	(1) D210-4 nut, gascolator mounting plug	70 in.-lb
(16) AN805 nuts, fuel primer line	20–30 in.-lb	
(1) AN894D4-2 bushing, primer system	50–65 in.-lb	

23-33 Special Torques (continued)

AREA	(QUANTITY) FASTENER	TORQUE
FUEL SYSTEM (CONT'D)	(1) AN894D6-4 bushing, primer system	110–130 in.-lb
	(4) MS27039C1-06 screws, fuel valve	16 in.-lb
	(4) MS27039DD1-26 screws, air bypass door	24 in.-lb
	(1) MS27769D2 plug, gascolator	60 in.-lb
	Primer system line assembly nuts, flared end fittings	20–30 in.-lb
FUSELAGE	(1) B277-052 clamp, lower rib	50 in.-lb
	(1) D210-5 nut, tow ball	240 in.-lb
	(8) MS51861-37C screws, door hinges	36 in.-lb
LANDING GEAR	(4) AN4-25A bolts, ground handling support	70 in.-lb
	(56) NAS6604 bolts, floats to skids and skid extensions	50 in.-lb
MAIN ROTOR BLADE	(2 per blade) A722-4 screw, tip weight retaining	40 in.-lb wet
	(2 per blade) B289-2 self-sealing bolts in pitch horn	70 in.-lb
	(2 per blade) NAS1351N3-10P screw, cover retaining	40 in.-lb wet
MAIN ROTOR GEARBOX	(1) AN320-8 nut, gearbox pinion	290–410 in.-lb
	(1) AN10-41A bolt, gearbox mounting (3) A650-1 fittings, gearbox mounting (requires MS21044N10 nuts)	90 ft-lb dry torqued from bolt head or nut
	(1) F650-3 bolt, gearbox mounting (3) A650-3 fittings, gearbox mounting (requires D210-10 nuts)	50 ft-lb, wet torque from bolt head or nut
	(6) NAS1352-4-14 screws in end cover	140 in.-lb
	(1) chip detector (threaded, non-quick-disconnect type)	Large nut 150 in.-lb Small nut 75 in.-lb
	(1) chip detector housing	150 in.-lb
	(1) nut, chip detector wiring	4–6 in.-lb
	(1) filler-plug	150 in.-lb
	(1) sight gage	150 in.-lb
MAIN ROTOR HUB	(1) NAS630-80 (or MS21250-10080) teeter hinge bolt; (2) NAS630-80 (or MS21250-10080) coning hinge bolts in A154-1 hub	New bolt: 0.016–0.017 inch elongation (stretch), wet Used bolt: 0.015–0.017 inch elongation, wet, & cotter pin holes must align
	(2) NAS632-82 (or MS21250-12082) coning hinge bolts in B370-1 hub	New bolt: 0.011–0.012 inch elongation (stretch), wet Used bolt: 0.010–0.012 inch elongation, wet, & cotter pin holes must align
OVERTRAVEL SPRING	(1) A486 screw, upper rod end	37 in.-lb
POWERPLANT	(1) A058-5 carburetor air temp probe	36–48 in.-lb
	(2) A740-1 manifold pressure line nuts	25–35 in.-lb
	(1) A760-1 oil temperature sender, single	300 in.-lb
	(1) A760-2 cylinder head temperature sender	50 in.-lb
	(1) A760-3 oil temperature sender, dual	300 in.-lb

23-33 Special Torques (continued)

AREA	(QUANTITY) FASTENER	TORQUE
POWERPLANT (CONT'D)	(1) B200-4 lug, bolt supplied with engine	96 in.-lb
	(1) C143-1 sensor assembly	96 in.-lb
	(2) B277-024 clamps, carb heat scoop	30 in.-lb
	(4) AN818-8 nuts, oil cooler line (stainless-steel lines)	40 ft-lb
	(4) AN818-8 nuts, oil cooler line (aluminum lines)	230-260 in.-lb
	(1) AN894D4-3 bushing, manifold pressure line, at firewall	135-150 in.-lb
	(4) MS20074-04-04 bolts, airbox-to-carburetor	30 in.-lb
	(1) 3080-00038 cylinder head temperature probe	70-80 in.-lb
	(1) bolt, alternator belt tension	204 in.-lb
	(4) bolts, D723-1 oil adapter	90-100 in.-lb
	(4) carburetor-to-engine nuts	96 in.-lb initial, 204 in.-lb final, torque in a crisscross pattern
	(8) exhaust riser flange nuts, plain	160-180 in.-lb
	(8) exhaust riser flange nuts, self-locking	200-220 in.-lb
	(2) ground strap-to-engine nuts	96 in.-lb
	(1) nut, B315-1 clip for magneto harness clamp	60 in.-lb
	(1) nut on A462-1 carburetor heat control wire-to-slider valve attach fitting	25-30 in.-lb
	(1) nut on A462-4 mixture control wire-to-carburetor mixture arm attach fitting	25-30 in.-lb
	(8) spark plugs	35 ft-lb wet with A257-16 oil
	(1) thermostatic oil cooler bypass valve	290-310 in.-lb
	(6 per cover) NAS1352-4H10P valve cover retaining screws when used with clean, dry, red silicon gasket on clean, dry valve cover and cylinder head mating surfaces	25 in.-lb cold engine, 20 in.-lb warm engine
(1) terminal retaining nut, alternator output terminal (use back-up wrench on stud retaining nut to prevent loss of stud clamp-up)	50 in.-lb	
(2) terminal retaining nuts, D748-3 alternator field and aux terminals (use back-up wrench on stud retaining nuts to prevent loss of stud clamp-up)	14 in.-lb	
(2) terminal retaining nuts, D748-4 alternator field and aux terminals (use back-up wrench on stud retaining nuts to prevent loss of stud clamp-up)	20 in.-lb	
(1) terminal retaining nut, oil temperature sender	20 in.-lb	
STEEL TUBE FRAME	(2) NAS1351-8H40P internal-wrenching screws	70-75 ft-lb wet
	(3) NAS6604-3 bolts - (1) lower-left frame aft strut-to-upper frame, and (2) on removable aft, right strut	120 in.-lb with B270-1 on shank to seal strut holes
SWASHPLATE	(2) NAS1352N08-6 screws, magnetic pick-up bracket	35 in.-lb
	(16) NAS1352N08-8 screws	35 in.-lb
	(1) NAS6605-8 bolt clamping early revision A203 yokes	190 in.-lb

23-33 Special Torques (continued)

AREA	(QUANTITY) FASTENER	TORQUE
SWASHPLATE (CONT'D)	(1 per link) 21FKF-616 jam nut, main rotor pitch link barrel	100 in.-lb
TAIL ROTOR GEARBOX	(1) B549-1 retainer, input seal	70 ft-lb wet
	(1) D210-4 nut, A031 pitch control housing stud	90 in.-lb
	(1) D210-4 nut, A119-1 bumper retainer	120 in.-lb
	(1) D210-8 nut retaining B546 input yoke on B021 gearbox	70 ft-lb wet with B270-11
	(3) MS20074-04-06 bolts, gearbox-to-tailcone mounting	100 in.-lb
	(8) MS20074-04-06 bolts on A021 gearbox	60 in.-lb
	(12) MS20074-04-06 bolts on B021 gearbox	100 in.-lb
	(1) NAS1304-38 bolt, spherical tail rotor teeter (delta) hinge	150 in.-lb
	(1) NAS6604-38 bolt, elastomeric tail rotor teeter (delta) hinge	150 in.-lb
	(1) chip detector on A021 gearbox	100 in.-lb
	(1) chip detector on B021 gearbox	60 in.-lb
	(1) nut, chip detector wiring on B021 gearbox	4-6 in.-lb
	(1) filler-plug vent assembly	100 in.-lb
	(1) sight gage on A021 gearbox	150 in.-lb
	(1) B563-4 (flat, UV filter) sight gage on B021 gearbox	150 in.-lb
(1) B563-1 (bubble) sight gage on B021 gearbox	100 in.-lb	
WINDSHIELD	(24) AN526C832R12 screw, thru center brace	16 in.-lb
	(64) B526-6 screw, polycarbonate windshield fasteners	24 in.-lb
	(1) B295-2 clip, yaw string	16 in.-lb

### 23-34 Push-Pull Tube Rod End Adjustment

**NOTE**

Refer to § 10.232 to adjust A258 main rotor pitch links.

The following procedure is standard for adjusting push-pull tube rod ends:

1. Loosen palnut and jam nut on rod end shank.
2. Remove hardware securing push-pull tube rod end to attachment point per respective instructions.
3. Screw rod end in or out of push-pull tube as required to obtain proper rigging adjustment. Apply B270-21 (corrosion) protectant to exposed threads.
4. After any rod end adjustment, verify rod end threaded shank blocks passage of 0.020-inch diameter wire thru the witness hole in the push-pull tube per Figure 2-1. When no witness hole is provided, refer to Figure 2-1 for maximum rod end extension.
5. Install fastener securing push-pull tube to attachment point per respective instructions.
6. Refer to Figure 2-1A. Position rod ends to allow as much push-pull tube rotation as possible without binding. Standard torque jam nuts & palnuts per § 23-32 & torque stripe per Figure 2-1.

### 23-35 D210-series Nuts on Critical Fasteners

When performing maintenance that involves disassembly of a critical fastener (joints with a secondary lock), reassemble the fastener using a D210-series nut.

If a fastener is disassembled that has an MS21042L-series or NAS1291-series nut with a B330-series palnut or B332-series lockwasher (secondary lock),

replace MS21042L08 nut or NAS1291-08 nut with D210-08 nut,  
replace MS21042L3 nut or NAS1291-3 nut with D210-3 nut,  
replace MS21042L4 nut or NAS1291-4 nut with D210-4 nut,  
replace MS21042L5 nut or NAS1291-5 nut with D210-5 nut,  
replace MS21042L6 nut or NAS1291-6 nut with D210-6 nut,  
replace NAS1291-7 nut with D210-7 nut,  
replace NAS1291-8 nut with D210-8 nut, or  
replace NAS1291-10 nut with D210-10 nut.

23-36 A880 Flared Tube Components

**A. Nuts – Flare**

Dash Numbers	Allowable Part Numbers	Material REF	Tube OD REF
-102	AN818-2D, AN818-2W, AS5175W02	AL	1/8-inch
-103	AN818-3D, AN818-3W, AS5175W03	AL	3/16-inch
-104	AN818-4D, AN818-4W, AS5175W04	AL	1/4-inch
-105	AN818-5D, AN818-5W, AS5175W05	AL	5/16-inch
-106	AN818-6D, AN818-6W, AS5175W06	AL	3/8-inch
-108	AN818-8D, AN818-8W, AS5175W08	AL	1/2-inch
-110	AN818-10D, AN818-10W, AS5175W10	AL	5/8-inch
-202	AN818-2J, AS5175J02	CRES	1/8-inch
-203	AN818-3J, AS5175J03	CRES	3/16-inch
-204	AN818-4J, AS5175J04	CRES	1/4-inch
-205	AN818-5J, AS5175J05	CRES	5/16-inch
-206	AN818-6J, AS5175J06	CRES	3/8-inch
-208	AN818-8J, AS5175J08	CRES	1/2-inch
-210	AN818-10J, AS5175J10	CRES	5/8-inch

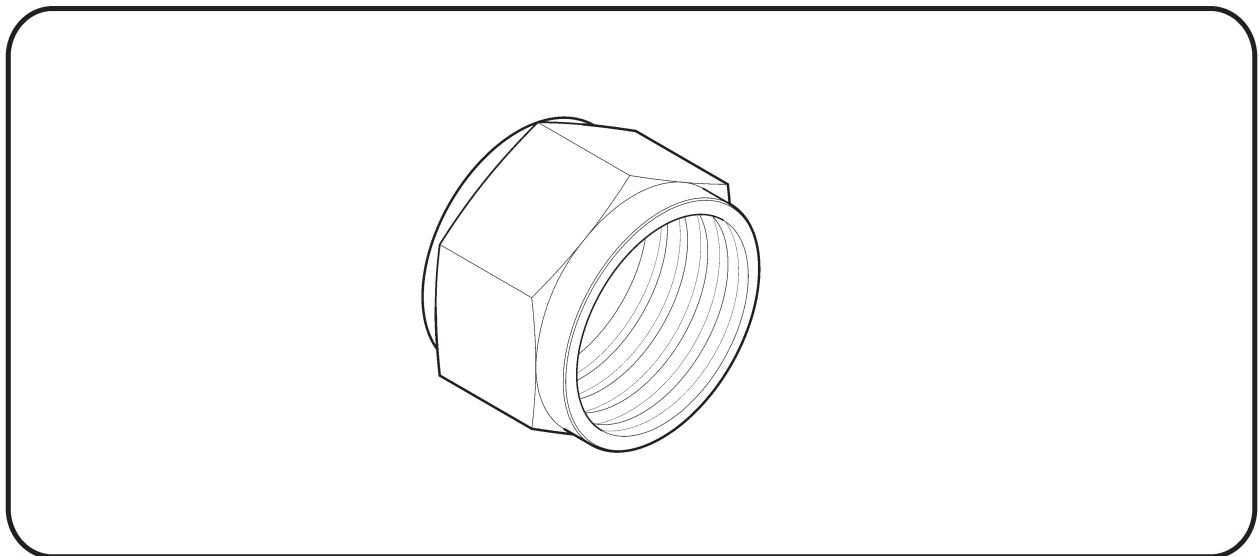



23-36 A880 Flared Tube Components (continued)

**B. Sleeves**

Dash Numbers	Allowable Part Numbers	Material REF	Tube OD REF
-302	MS20819-2D, AS3220D02, AS3220W02	AL	1/8-inch
-303	MS20819-3D, AS3220D03, AS3220W03	AL	3/16-inch
-304	MS20819-4D, AS3220D04, AS3220W04	AL	1/4-inch
-305	MS20819-5D, AS3220D05, AS3220W05	AL	5/16-inch
-306	MS20819-6D, AS3220D06, AS3220W06	AL	3/8-inch
-308	MS20819-8D, AS3220D08, AS3220W08	AL	1/2-inch
-310	MS20819-10D, AS3220D10, AS3220W10	AL	5/8-inch
-402	MS20819-2J, AS5176J02	CRES	1/8-inch
-403	MS20819-3J, AS5176J03	CRES	3/16-inch
-404	MS20819-4J, AS5176J04	CRES	1/4-inch
-405	MS20819-5J, AS5176J05	CRES	5/16-inch
-406	MS20819-6J, AS5176J06	CRES	3/8-inch
-408	MS20819-8J, AS5176J08	CRES	1/2-inch
-410	MS20819-10J, AS5176J10	CRES	5/8-inch

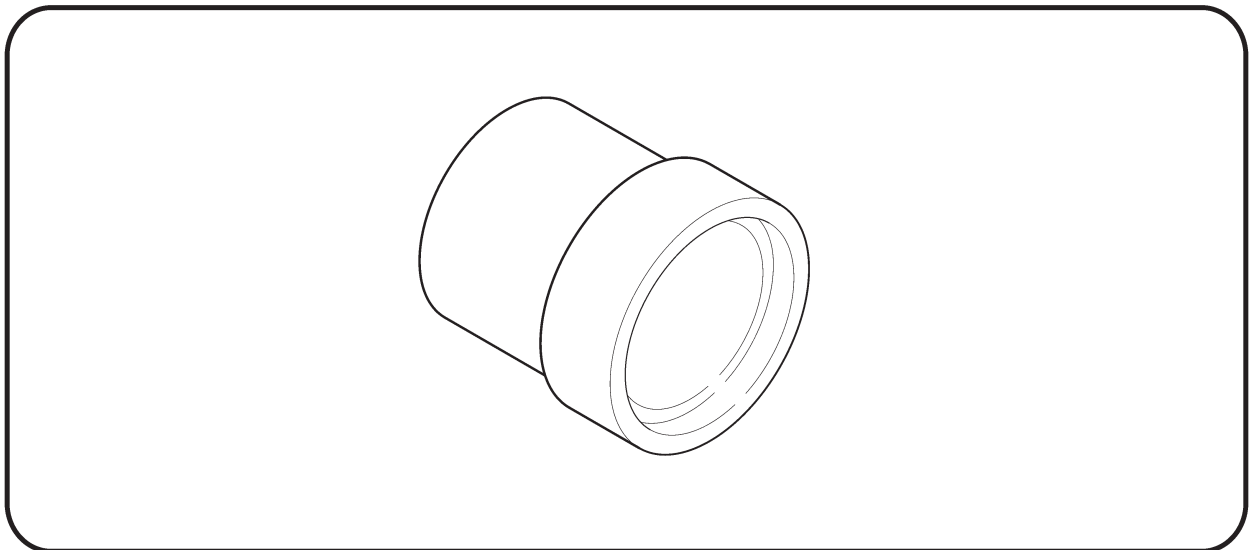

23-36 A880 Flared Tube Components (continued)

**C. Adapters – NPT to Flare**

Dash Numbers	Allowable Part Numbers	Material REF	Tube OD REF
-502	AN816-2D, AS5194D0202	AL	1/8-inch
-503	AN816-3D, AS5194D0302	AL	3/16-inch
-504	AN816-4D, AS5194D0402	AL	1/4-inch
-505	AN816-5D, AS5194D0502	AL	5/16-inch
-506	AN816-6D, AS5194D0604	AL	3/8-inch
-508	AN816-8D, AS5194D0806	AL	1/2-inch
-510	AN816-10D, AS5194D1008	AL	5/8-inch
-532	AN816-2J, AS5194J0202	CRES	1/8-inch
-533	AN816-3J, AS5194J0302	CRES	3/16-inch
-534	AN816-4J, AS5194J0402	CRES	1/4-inch
-535	AN816-5J, AS5194J0502	CRES	5/16-inch
-536	AN816-6J, AS5194J0604	CRES	3/8-inch
-538	AN816-8J, AS5194J0806	CRES	1/2-inch
-540	AN816-10J, AS5194J1008	CRES	5/8-inch
-562	AN816-2, AS5194-0202	STL	1/8-inch
-563	AN816-3, AS5194-0302	STL	3/16-inch
-564	AN816-4, AS5194-0402	STL	1/4-inch
-565	AN816-5, AS5194-0502	STL	5/16-inch
-566	AN816-6, AS5194-0604	STL	3/8-inch
-568	AN816-8, AS5194-0806	STL	1/2-inch
-570	AN816-10, AS5194-1008	STL	5/8-inch

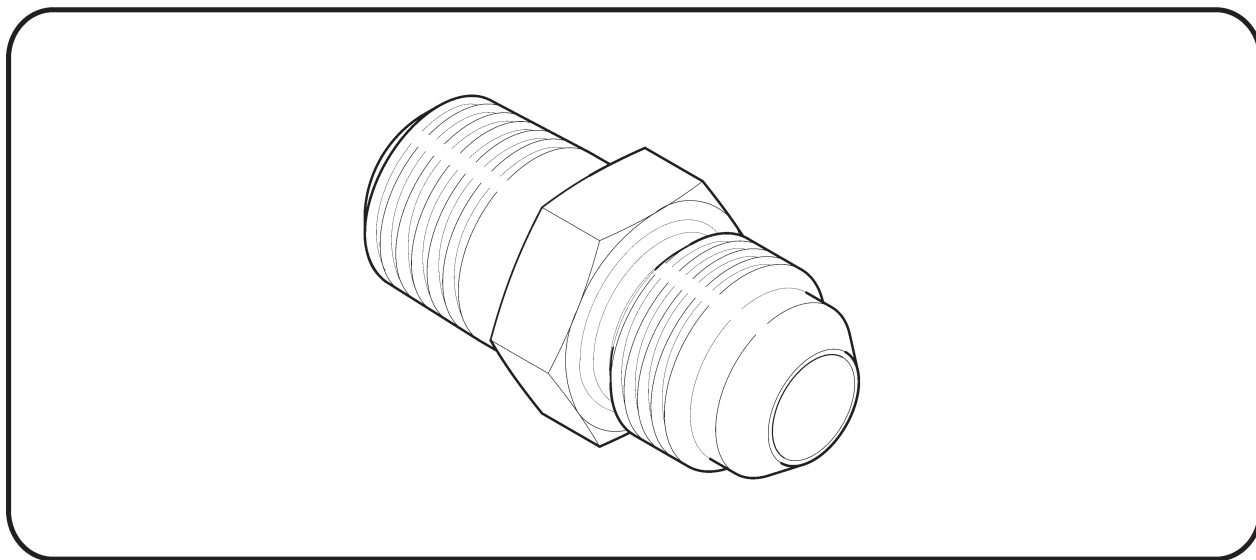

23-36 A880 Flared Tube Components (continued)

**D. Elbows – 90°, NPT to Flare**

Dash Numbers	Allowable Part Numbers	Material REF	Tube OD REF
-602	AN822-2D, MS20822-2D, AS5195W0202	AL	1/8-inch
-603	AN822-3D, MS20822-3D, AS5195W0302	AL	3/16-inch
-604	AN822-4D, MS20822-4D, AS5195W0402	AL	1/4-inch
-605	AN822-5D, MS20822-5D, AS5195W0502	AL	5/16-inch
-606	AN822-6D, MS20822-6D, AS5195W0604	AL	3/8-inch
-608	AN822-8D, MS20822-8D, AS5195W0806	AL	1/2-inch
-610	AN822-10D, MS20822-10D, AS5195W1008	AL	5/8-inch
-632	AN822-2J, MS20822-2J, AS5195J0202	CRES	1/8-inch
-633	AN822-3J, MS20822-3J, AS5195J0302	CRES	3/16-inch
-634	AN822-4J, MS20822-4J, AS5195J0402	CRES	1/4-inch
-635	AN822-5J, MS20822-5J, AS5195J0502	CRES	5/16-inch
-636	AN822-6J, MS20822-6J, AS5195J0604	CRES	3/8-inch
-638	AN822-8J, MS20822-8J, AS5195J0806	CRES	1/2-inch
-640	AN822-10J, MS20822-10J, AS5195J1008	CRES	5/8-inch
-662	AN822-2, MS20822-2, AS5195-0202	STL	1/8-inch
-663	AN822-3, MS20822-3, AS5195-0302	STL	3/16-inch
-664	AN822-4, MS20822-4, AS5195-0402	STL	1/4-inch
-665	AN822-5, MS20822-5, AS5195-0502	STL	5/16-inch
-666	AN822-6, MS20822-6, AS5195-0604	STL	3/8-inch
-668	AN822-8, MS20822-8, AS5195-0806	STL	1/2-inch
-670	AN822-10, MS20822-10, AS5195-1008	STL	5/8-inch

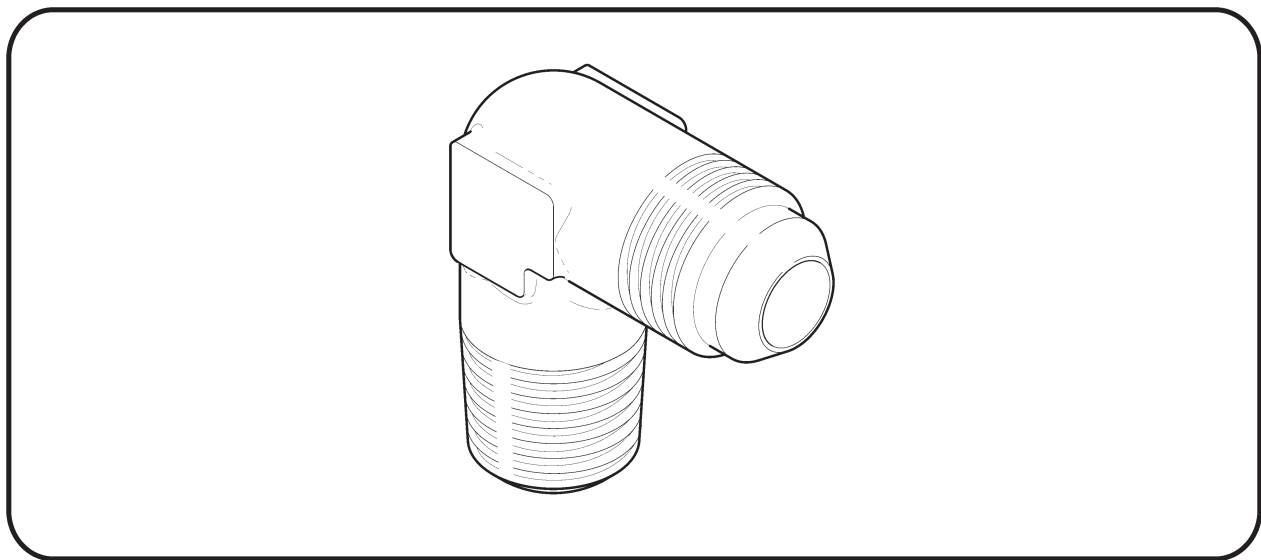

23-36 A880 Flared Tube Components (continued)

**E. Elbows – 45°, NPT to Flare**

Dash Numbers	Allowable Part Numbers	Material REF	Tube OD REF
-702	AN823-2D, MS20823-2D, AS5196W0202	AL	1/8-inch
-703	AN823-3D, MS20823-3D, AS5196W0302	AL	3/16-inch
-704	AN823-4D, MS20823-4D, AS5196W0402	AL	1/4-inch
-705	AN823-5D, MS20823-5D, AS5196W0502	AL	5/16-inch
-706	AN823-6D, MS20823-6D, AS5196W0604	AL	3/8-inch
-708	AN823-8D, MS20823-8D, AS5196W0806	AL	1/2-inch
-710	AN823-10D, MS20823-10D, AS5196W1008	AL	5/8-inch
-732	AN823-2J, MS20823-2J, AS5196J0202	CRES	1/8-inch
-733	AN823-3J, MS20823-3J, AS5196J0302	CRES	3/16-inch
-734	AN823-4J, MS20823-4J, AS5196J0402	CRES	1/4-inch
-735	AN823-5J, MS20823-5J, AS5196J0502	CRES	5/16-inch
-736	AN823-6J, MS20823-6J, AS5196J0604	CRES	3/8-inch
-738	AN823-8J, MS20823-8J, AS5196J0806	CRES	1/2-inch
-740	AN823-10J, MS20823-10J, AS5196J1008	CRES	5/8-inch
-762	AN823-2, MS20823-2, AS5196-0202	STL	1/8-inch
-763	AN823-3, MS20823-3, AS5196-0302	STL	3/16-inch
-764	AN823-4, MS20823-4, AS5196-0402	STL	1/4-inch
-765	AN823-5, MS20823-5, AS5196-0502	STL	5/16-inch
-766	AN823-6, MS20823-6, AS5196-0604	STL	3/8-inch
-768	AN823-8, MS20823-8, AS5196-0806	STL	1/2-inch
-770	AN823-10, MS20823-10, AS5196-1008	STL	5/8-inch

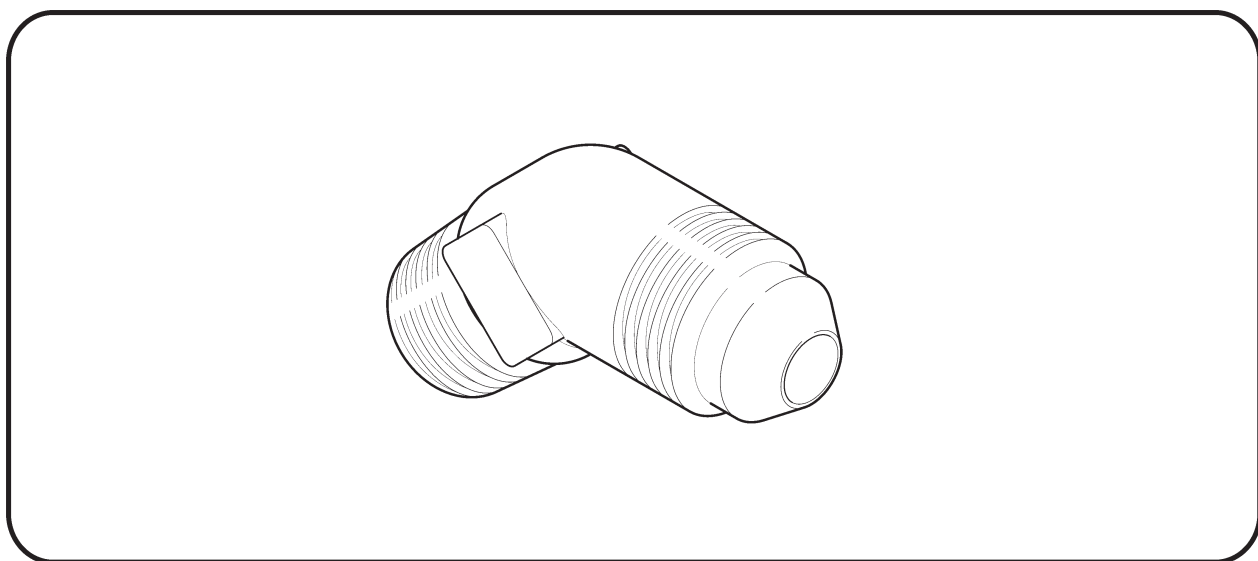

23-36 A880 Flared Tube Components (continued)

**F. Elbows – 90°, Bulkhead Flare to Flare**

Dash Numbers	Allowable Part Numbers	Material REF	Tube OD REF
-802	AN833-2D, AS1038D0202, AS1038W0202	AL	1/8-inch
-803	AN833-3D, AS1038D0303, AS1038W0303	AL	3/16-inch
-804	AN833-4D, AS1038D0404, AS1038W0404	AL	1/4-inch
-805	AN833-5D, AS1038D0505, AS1038W0505	AL	5/16-inch
-806	AN833-6D, AS1038D0606, AS1038W0606	AL	3/8-inch
-808	AN833-8D, AS1038D0808, AS1038W0808	AL	1/2-inch
-810	AN833-10D, AS1038D1010, AS1038W1010	AL	5/8-inch
-832	AN833-2J, AS1038J0202	CRES	1/8-inch
-833	AN833-3J, AS1038J0303	CRES	3/16-inch
-834	AN833-4J, AS1038J0404	CRES	1/4-inch
-835	AN833-5J, AS1038J0505	CRES	5/16-inch
-836	AN833-6J, AS1038J0606	CRES	3/8-inch
-838	AN833-8J, AS1038J0808	CRES	1/2-inch
-840	AN833-10J, AS1038J1010	CRES	5/8-inch
-862	AN833-2, AS1038-0202	STL	1/8-inch
-863	AN833-3, AS1038-0303	STL	3/16-inch
-864	AN833-4, AS1038-0404	STL	1/4-inch
-865	AN833-5, AS1038-0505	STL	5/16-inch
-866	AN833-6, AS1038-0606	STL	3/8-inch
-868	AN833-8, AS1038-0808	STL	1/2-inch
-870	AN833-10, AS1038-1010	STL	5/8-inch

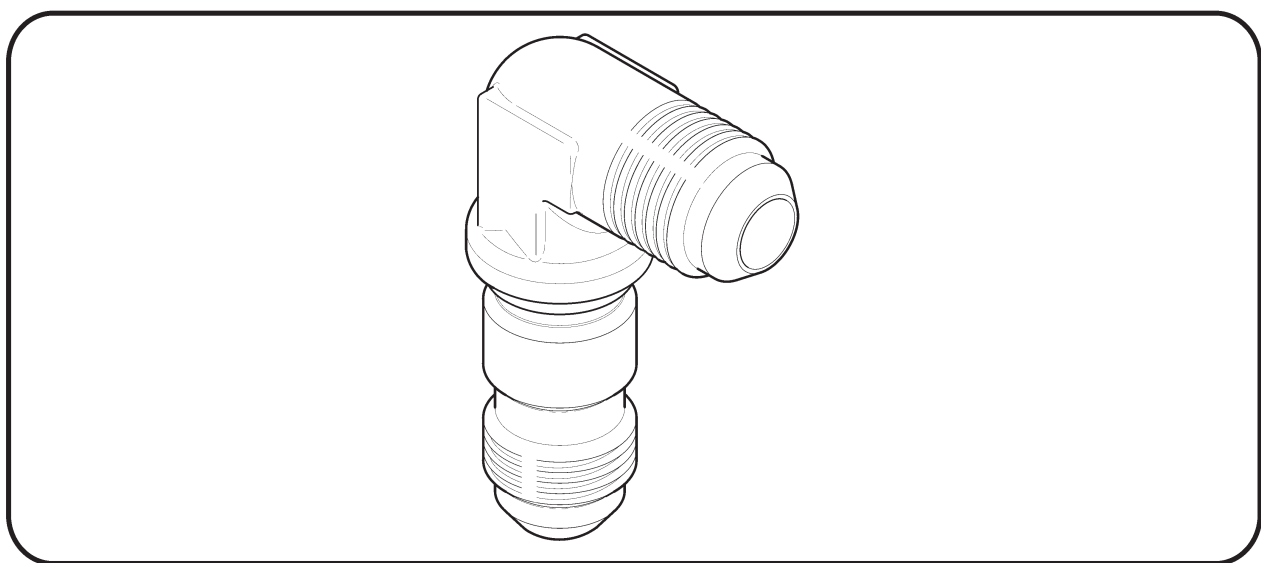

23-36 A880 Flared Tube Components (continued)

**G. Unions – Flare to Flare**

Dash Numbers	Allowable Part Numbers	Material REF	Tube OD REF
-902	AN815-2D, AS5174D0202, AS5174W0202	AL	1/8-inch
-903	AN815-3D, AS5174D0303, AS5174W0303	AL	3/16-inch
-904	AN815-4D, AS5174D0404, AS5174W0404	AL	1/4-inch
-905	AN815-5D, AS5174D0505, AS5174W0505	AL	5/16-inch
-906	AN815-6D, AS5174D0606, AS5174W0606	AL	3/8-inch
-908	AN815-8D, AS5174D0808, AS5174W0808	AL	1/2-inch
-910	AN815-10D, AS5174D1010, AS5174W1010	AL	5/8-inch
-932	AN815-2J, AS5174J0202	CRES	1/8-inch
-933	AN815-3J, AS5174J0303	CRES	3/16-inch
-934	AN815-4J, AS5174J0404	CRES	1/4-inch
-935	AN815-5J, AS5174J0505	CRES	5/16-inch
-936	AN815-6J, AS5174J0606	CRES	3/8-inch
-938	AN815-8J, AS5174J0808	CRES	1/2-inch
-940	AN815-10J, AS5174J1010	CRES	5/8-inch
-962	AN815-2, AS5174-0202	STL	1/8-inch
-963	AN815-3, AS5174-0303	STL	3/16-inch
-964	AN815-4, AS5174-0404	STL	1/4-inch
-965	AN815-5, AS5174-0505	STL	5/16-inch
-966	AN815-6, AS5174-0606	STL	3/8-inch
-968	AN815-8, AS5174-0808	STL	1/2-inch
-970	AN815-10, AS5174-1010	STL	5/8-inch

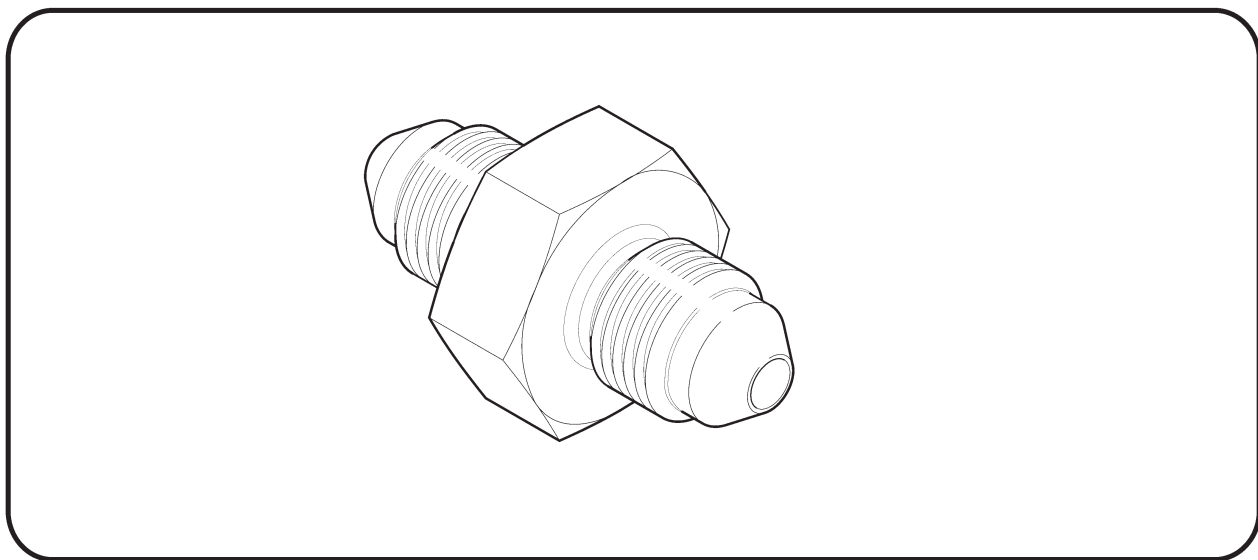

23-36 A880 Flared Tube Components (continued)

**H. Nuts – Hex**

Dash Numbers	Allowable Part Numbers	Material REF	Tube OD REF
-1002	AN924-2D, AN924-2W, AS5178W02	AL	1/8-inch
-1003	AN924-3D, AN924-3W, AS5178W03	AL	3/16-inch
-1004	AN924-4D, AN924-4W, AS5178W04	AL	1/4-inch
-1005	AN924-5D, AN924-5W, AS5178W05	AL	5/16-inch
-1006	AN924-6D, AN924-6W, AS5178W06	AL	3/8-inch
-1008	AN924-8D, AN924-8W, AS5178W08	AL	1/2-inch
-1010	AN924-10D, AN924-10W, AS5178W10	AL	5/8-inch
-1032	AN924-2J, AS5178J02	CRES	1/8-inch
-1033	AN924-3J, AS5178J03	CRES	3/16-inch
-1034	AN924-4J, AS5178J04	CRES	1/4-inch
-1035	AN924-5J, AS5178J05	CRES	5/16-inch
-1036	AN924-6J, AS5178J06	CRES	3/8-inch
-1038	AN924-8J, AS5178J08	CRES	1/2-inch
-1040	AN924-10J, AS5178J10	CRES	5/8-inch
-1062	AN924-2, AS5178-02	STL	1/8-inch
-1063	AN924-3, AS5178-03	STL	3/16-inch
-1064	AN924-4, AS5178-04	STL	1/4-inch
-1065	AN924-5, AS5178-05	STL	5/16-inch
-1066	AN924-6, AS5178-06	STL	3/8-inch
-1068	AN924-8, AS5178-08	STL	1/2-inch
-1070	AN924-10, AS5178-10	STL	5/8-inch

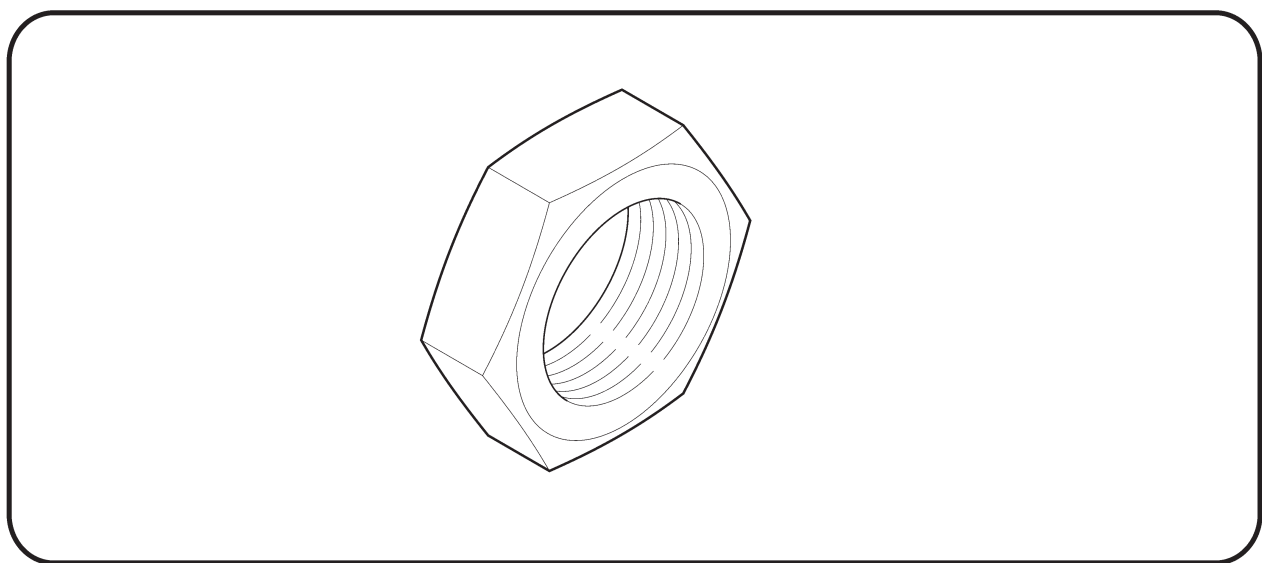

23-36 A880 Flared Tube Components (continued)

**I. Tees – NPT to Flare**

Dash Numbers	Allowable Part Numbers	Material REF	Tube OD REF
-1102	AN826-2D, MS20826-2D, AS5198W020202	AL	1/8-inch
-1103	AN826-3D, MS20826-3D, AS5198W030203	AL	3/16-inch
-1104	AN826-4D, MS20826-4D, AS5198W040204	AL	1/4-inch
-1105	AN826-5D, MS20826-5D, AS5198W050205	AL	5/16-inch
-1106	AN826-6D, MS20826-6D, AS5198W060406	AL	3/8-inch
-1108	AN826-8D, MS20826-8D, AS5198W080608	AL	1/2-inch
-1110	AN826-10D, MS20826-10D, AS5198W100810	AL	5/8-inch
-1132	AN826-2J, MS20826-2J, AS5198J020202	CRES	1/8-inch
-1133	AN826-3J, MS20826-3J, AS5198J030203	CRES	3/16-inch
-1134	AN826-4J, MS20826-4J, AS5198J040204	CRES	1/4-inch
-1135	AN826-5J, MS20826-5J, AS5198J050205	CRES	5/16-inch
-1136	AN826-6J, MS20826-6J, AS5198J060406	CRES	3/8-inch
-1138	AN826-8J, MS20826-8J, AS5198J080608	CRES	1/2-inch
-1140	AN826-10J, MS20826-10J, AS5198J100810	CRES	5/8-inch
-1162	AN826-2, MS20826-2, AS5198-020202	STL	1/8-inch
-1163	AN826-3, MS20826-3, AS5198-030203	STL	3/16-inch
-1164	AN826-4, MS20826-4, AS5198-040204	STL	1/4-inch
-1165	AN826-5, MS20826-5, AS5198-050205	STL	5/16-inch
-1166	AN826-6, MS20826-6, AS5198-060406	STL	3/8-inch
-1168	AN826-8, MS20826-8, AS5198-080608	STL	1/2-inch
-1170	AN826-10, MS20826-10, AS5198-100810	STL	5/8-inch

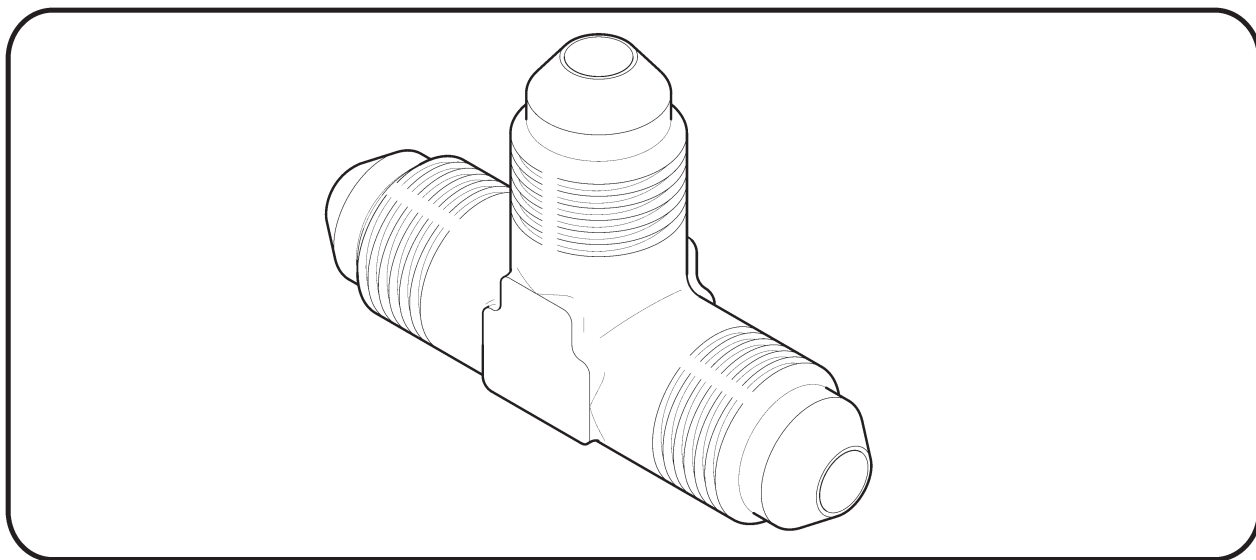



23-36 A880 Flared Tube Components (continued)

**J. Plugs without Holes**

Dash Numbers	Allowable Part Numbers	Material REF	Tube OD REF
-1202	AN814-2D, AN814-2W, AS5169D02, AS5169W02	AL	1/8-inch
-1203	AN814-3D, AN814-3W, AS5169D03, AS5169W03	AL	3/16-inch
-1204	AN814-4D, AN814-4W, AS5169D04, AS5169W04	AL	1/4-inch
-1205	AN814-5D, AN814-5W, AS5169D05, AS5169W05	AL	5/16-inch
-1206	AN814-6D, AN814-6W, AS5169D06, AS5169W06	AL	3/8-inch
-1208	AN814-8D, AN814-8W, AS5169D08, AS5169W08	AL	1/2-inch
-1210	AN814-10D, AN814-10W, AS5169D10, AS5169W10	AL	5/8-inch
-1232	AN814-2J, AS5169J02	CRES	1/8-inch
-1233	AN814-3J, AS5169J03	CRES	3/16-inch
-1234	AN814-4J, AS5169J04	CRES	1/4-inch
-1235	AN814-5J, AS5169J05	CRES	5/16-inch
-1236	AN814-6J, AS5169J06	CRES	3/8-inch
-1238	AN814-8J, AS5169J08	CRES	1/2-inch
-1240	AN814-10J, AS5169J10	CRES	5/8-inch
-1262	AN814-2, AS5169-02	STL	1/8-inch
-1263	AN814-3, AS5169-03	STL	3/16-inch
-1264	AN814-4, AS5169-04	STL	1/4-inch
-1265	AN814-5, AS5169-05	STL	5/16-inch
-1266	AN814-6, AS5169-06	STL	3/8-inch
-1268	AN814-8, AS5169-08	STL	1/2-inch
-1270	AN814-10, AS5169-10	STL	5/8-inch

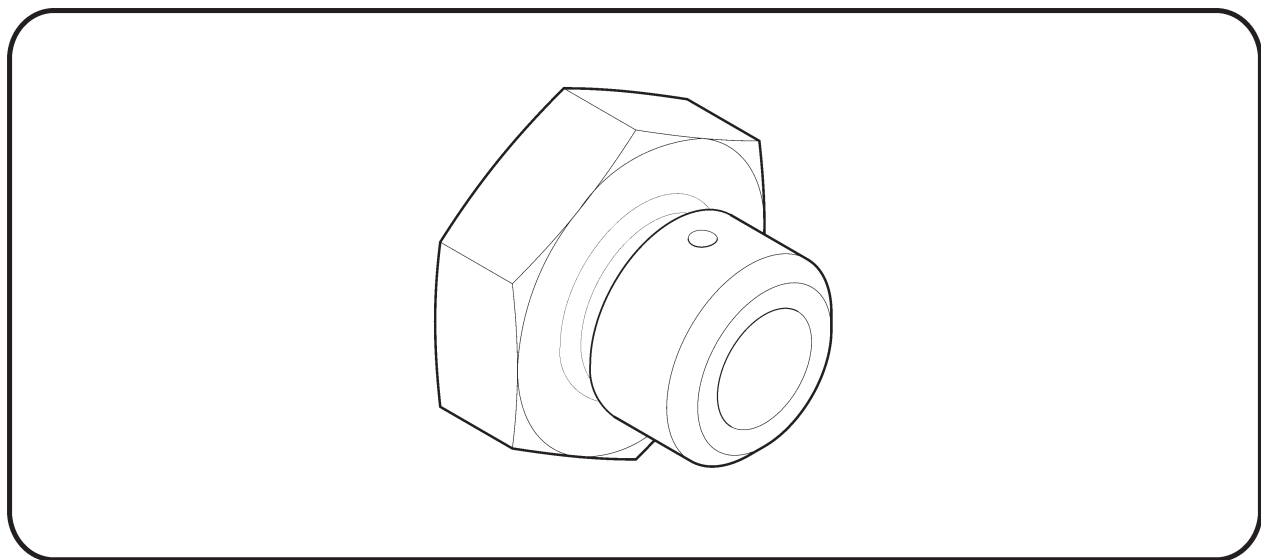

23-36 A880 Flared Tube Components (continued)

**K. Plugs with Holes**

Dash Numbers	Allowable Part Numbers	Material REF	Tube OD REF
-1302	AN814-2DL, AN814-2WL, AS5169D02L, AS5169W02L	AL	1/8-inch
-1303	AN814-3DL, AN814-3WL, AS5169D03L, AS5169W03L	AL	3/16-inch
-1304	AN814-4DL, AN814-4 WL, AS5169D04L, AS5169W04L	AL	1/4-inch
-1305	AN814-5DL, AN814-5WL, AS5169D05L, AS5169W05L	AL	5/16-inch
-1306	AN814-6DL, AN814-6WL, AS5169D06L, AS5169W06L	AL	3/8-inch
-1308	AN814-8DL, AN814-8WL, AS5169D08L, AS5169W08L	AL	1/2-inch
-1310	AN814-10DL, AN814-10WL, AS5169D10L, AS5169W10L	AL	5/8-inch
-1332	AN814-2JL, AS5169J02L	CRES	1/8-inch
-1333	AN814-3JL, AS5169J03L	CRES	3/16-inch
-1334	AN814-4JL, AS5169J04L	CRES	1/4-inch
-1335	AN814-5JL, AS5169J05L	CRES	5/16-inch
-1336	AN814-6JL, AS5169J06L	CRES	3/8-inch
-1338	AN814-8JL, AS5169J08L	CRES	1/2-inch
-1340	AN814-10JL, AS5169J10L	CRES	5/8-inch
-1362	AN814-2L, AS5169-02L	STL	1/8-inch
-1363	AN814-3L, AS5169-03L	STL	3/16-inch
-1364	AN814-4L, AS5169-04L	STL	1/4-inch
-1365	AN814-5L, AS5169-05L	STL	5/16-inch
-1366	AN814-6L, AS5169-06L	STL	3/8-inch
-1368	AN814-8L, AS5169-08L	STL	1/2-inch
-1370	AN814-10L, AS5169-10L	STL	5/8-inch

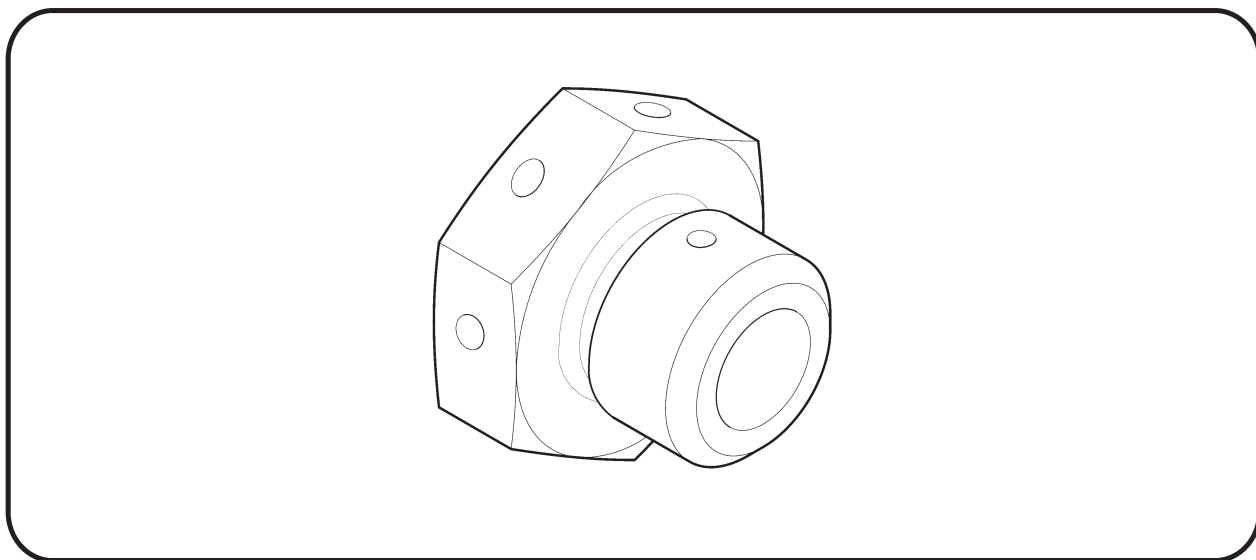

Intentionally Blank

23-40 Non-Destructive Testing**WARNING**

**Review appropriate Safety Data Sheet (SDS) when working in proximity to hazardous materials. Specific recommendations for use of personal protective equipment are located in the SDS.**

23-41 Magnetic Particle Inspection

Ferromagnetic steel parts are inspected for structural defects using magnetic particle inspection. Steel parts covered by this specification are inspected per ASTM E1444 wet continuous process with ultra-violet light. Applicable requirements and limitations of the above standard apply.

Procedures and equipment used to perform the inspection shall conform to requirements of ASTM E1444. A magneto test penetrometer or a 30–60 gauss meter is used to verify the direction and effectiveness of all magnetic fields produced. Whenever possible, parts shall be inspected with both circular and longitudinal magnetization, but at least in two directions at right angles to each other. Minimum duration of application is ½ second.

Pre- and post-solvent clean parts using PCBTF or similar solvent. Demagnetizing is accomplished using AC ± 3 oersteds maximum. Verify part is demagnetized using a magnetic field strength indicator which does not exceed an absolute value above three gauss.

Area of part to be examined, position of part, directions of magnetization to be used and method of establishing the magnetization are presented within the inspection section of individual parts. Record the size and location of all rejectable indications.

**A. Inspection Criteria**

Parts (except gears) which are inspected by magnetic particle inspection shall be accepted or rejected according to the following criteria:

Acceptable indications:

- Indications smaller than 0.015 inch are not considered rateable.
- Indications caused by sharp changes in cross-section or part geometry.

Rejectable indications:

- Indications interpreted as cracks, seams, laps, shuts, or any flaws which are open to the surface.
- Indications oriented at an angle of more than 15 degrees from the longitudinal axis with length exceeding 0.125 inch.
- Circumferential indications on any shoulder or fillet (changes in diameter).
- Any indications which break over an edge, shoulder, fillet radius, keyway, spline, or an adjacent area of part more than 0.015 inch.
- Indications caused by undercuts at the toe of a weld.
- Indications caused by cracks in the weld or parent metal.
- Indications caused by inclusions in weld material exceeding 0.1 inch in length.

### 23-42 Fluorescent Penetrant Inspection

This specification provides for surface inspection of parts fabricated from nonmagnetic materials to detect discontinuities open to the surface, such as cracks, cold shuts, laps, porosity and other surface defects.

Applicable requirements and limitations of ASTM E1417 shall apply. After inspection is complete, solvent clean parts.

The step-by-step procedure and equipment used to perform the inspection shall be accomplished per ASTM E1417. The following types, methods, and sensitivity levels are recommended:

Type: 1–Fluorescent dye  
Method: A–Water washable  
Sensitivity: Level 2–Medium  
Form: A–Dry powder

#### **A. Inspection Criteria**

Parts inspected by fluorescent penetrant method shall be accepted or rejected on basis of acceptance limits specified. If acceptance limits are not specified, rejectable surface defects and any of the following:

- Cracks
- Seams
- Cold shuts or laps
- Surface inclusions
- In castings, aligned discontinuous surface indications other than cracks, cold shuts and inclusions are rejectable if more than 3/8 inch in length.

### 23-50 Corrosion Control

#### 23-51 Conversion Coat – Aluminum

Use the following procedures to prepare and apply conversion coat to aluminum alloys. Conversion coat improves corrosion resistance and adherence of paint and adhesives.

#### **CAUTION**

Do not allow Bonderite C-IC 33 Aero or M-CR 1201/1132 Aero to contact bonded joints.

#### **A. Procedure**

1. Unless otherwise specified, lightly scuff clean surface with 320-grit aluminum-oxide abrasive paper to remove corrosion or other contaminants.
2. Apply Bonderite C-IC 33 Aero to surface for 2–5 minutes. DO NOT allow Bonderite C-IC 33 Aero to dry; re-apply as required.
3. Rinse thoroughly with clean, potable water.

23-51 Conversion Coat – Aluminum (continued)**A. Procedure (continued)**

4. Apply Bonderite M-CR 1201 Aero to surface for 2–5 minutes (should be light golden brown). DO NOT allow Bonderite M-CR 1201 Aero to dry; re-apply as required.
5. Rinse thoroughly with clean, potable water. Gently wipe with clean & dry cloth, blow dry, or allow to air dry.

**B. Felt Tip Applicator**

Apply Bonderite M-CR 1132 Aero per manufacturer’s recommendations.

23-60 Priming and Painting

This specification outlines preparation and application requirements for primers and topcoat. Primers provide corrosion protection and a final finish or a base for topcoat. Approved materials are listed in § 23-70.

Unless directed, do not prime or paint the following:

- Sliding friction joints.
- Stainless steel parts.
- Swivel joints and adjustable rod ends.
- Plastic, rubber, electrical components and wires or similar materials.
- Bolted joints where torque is a specific requirement for clamping action.
- Bearing press-fit, or close tolerance slip-fit, joints (except where wet primer is part of the assembly procedure).

**WARNING**

**Review appropriate Safety Data Sheet (SDS) when working in proximity to hazardous materials. Specific recommendations for use of personal protective equipment are located in the SDS.**

**A. Priming**

1. Preparing Aluminum (for Steel parts see step 2)

Unless otherwise specified, conversion coating per § 23-51 is standard treatment before priming aluminum. If bare aluminum is primed without conversion coating, the following procedure must be used:

- a. Alkaline clean if immersion is practical, otherwise wipe clean with an approved degreasing agent. Do not allow alkaline cleaner to contact bonded joints.
- b. Lightly scuff the surface with Scotch-Brite pads.
- c. Wipe with a tack rag to remove any foreign material or damp wipe with an approved solvent.
- d. Air dry. Do not touch parts with bare hands until primed.

23-60 Priming and Painting (continued)**A. Priming (continued)**

## 2. Preparing Steel (for Aluminum see step 1)

Alkaline clean is the preferred method for cleaning stainless steel. Alternately, stainless steel may be cleaned using an approved solvent. Do not allow alkaline cleaner to contact bonded joints.

Steel parts should only be cleaned using an approved solvent; using an alkaline cleaning process on steel may cause a corrosive reaction.

Where immersion is not practical or for extremely greasy or dirty parts, a preclean in a solvent vapor degreaser may be used.

Air or blow dry using filtered, dry, compressed air.

## 3. Application

Apply primer after mixing per manufacturer's recommendations. Primer coating is not to exceed 0.0005–0.0020 inch thickness per coat. For parts with internal openings, such as tubes, prime the inside as follows:

- a. Thin primer to watery consistency using required reducer.
- b. Pour in primer, slosh around, then drain immediately.
- c. Dry parts at least (6) hours before using.

## 4. Inspection

Inspect for complete coverage and excessive thickness. If primer is excessively thick, strip part and re-prime. Refer to § 23-70 for approved materials.

**NOTE**

Primed areas that have been sanded to bare metal must have conversion coating (if required) and primer re-applied prior to topcoat to restore anti-corrosion properties.

**B. Painting Topcoat**

Prior to liquid topcoat application, ensure surfaces have been cleaned and primed. In general, most parts will be cleaned and primed as detail parts. However, in some cases, such as the gearbox assembly, this is not practical and primer and topcoat are applied on the assembled component.

Previously primed surfaces, or primed surfaces that have completely cured require the following preparation before paint:

1. Lightly sand using 220-grit or finer aluminum-oxide abrasive paper.
2. Lightly scuff with Scotch Brite pads (optional).
3. Wipe with clean cloth and approved solvent.
4. Wipe with tack cloth.
5. Apply topcoat.

Intentionally Blank



23-70 Approved Materials

The following items are available from the noted manufacturer(s) or their distributor(s). Check with appropriate regulatory authority(s) for allowable usage of materials.

**WARNING**

**Review appropriate Safety Data Sheet (SDS) when working in proximity to hazardous materials. Specific recommendations for use of personal protective equipment are located in the SDS.**

**CAUTION**

Follow product manufacturer’s instructions for handling and storage.

23-71 Paint Strippers

PRODUCT	MANUFACTURER/SUPPLIER	APPLICATION
Cee-Bee Stripper A-292	McGean-Rohco: Cee-Bee Division Downey, CA	Metal parts, except blades and flex plates.
Plastic Media Blasting System	Pauli & Griffin Co. Vacaville, CA	Metal parts except blades and unsupported sheet metal less than 0.040 inch thick.

23-72 Solvents and Cleaners

PRODUCT	MANUFACTURER/SUPPLIER	APPLICATION
QSOL 220	Safety-Kleen Systems, Inc. Plano, TX	General use and for cleaning prior to applying primer, topcoat, adhesive, or sealant.
Benzene, 1-Chloro-4 (Trifluoromethyl) PCBTF***	Any	“ ”
Acetone***	Any	“ ”
3821S Low VOC Cleaner	Axalta, Wilmington, DE	“ ”
Final Klean 3909S	Du Pont Chemical Los Angeles, CA	“ ”
SP Aerospace Prep Surface Cleaner	AkzoNobel, Waukegan, IL	“ ”
EM-Citro*	LPS Laboratories, Inc. Tucker, GA	Remove adhesive residue on cabin and windshield.
Lacolene (Aliphatic Hydrocarbon)	Any	Windshield and plastic cleaning.
Plexus®	B.T.I. Chemical Co. Oak Park, CA	“ ”
Presolve	LPS Laboratories, Inc. Tucker, GA	Hydraulic components only.
Tetrachloroethylene (Perchloroethylene)	Any	Vapor degreaser.

23-72 Solvents and Cleaners (continued)

PRODUCT	MANUFACTURER/SUPPLIER	APPLICATION
815 GD	Brulin Corporation Indianapolis, IN	Ultrasonic cleaning, general use. * *
SF50	L&R Mfg. Co. Kearny, NJ	" "
#112 Ammoniated or #222 Nonammoniated cleaning & rinse solution	L&R Mfg. Co. Kearny, NJ	Ultrasonic cleaning, avionics components only.
Cleanup Wipe E-4365	Sontara Candler, NC	Cleaning and drying.
Snoop Liquid Leak Detector	Swagelok Solon, OH	Leak detector.

\* May be used on acrylic plastic.

\*\* Mix 5%-20% by volume; titration not required.

\*\*\* Acetone and PCBTF may be mixed 50-50.

23-73 Fillers and Putty

PRODUCT	MANUFACTURER/SUPPLIER	APPLICATION
05096 Glazing Putty 05860 Dry Guide Coat 31180 Finishing Glaze	3M St. Paul, MN	Minor surface imperfections.
SBF1191 Filler	Gearhead Products Indianapolis, IN	" "
FE-351 Cream Hardener	Catalyst Systems Gnadenhutten, OH	" "

23-74 Torque Seal

PRODUCT	MANUFACTURER/SUPPLIER	APPLICATION
83314 thru 83321 Except 83316 (red)	Dykem Cross-Check ITW Pro Brands	Torque seal.

23-75 Primers

**A. Non-chromate Primers**

	<b>Corlar 13580S*</b>	<b>Desoprime CA7502*</b>	<b>Desoprime CA7422*</b>
<b>Manufacturer</b>	Axalta	PPG	PPG
<b>Base</b>	Corlar 13580S Epoxy Primer	CA7502A	CA7422A
<b>Activator</b>	Corlar 13180S Epoxy Activator	CA7502B	CA7422B
<b>Reducer</b>	13756S VOC-Exempt Reducer	CA7502C	CA7422C
<b>Base: Activator: Reducer</b>	4:1:1	4:4:1	4:4:1
<b>Viscosity</b>	17-21 sec in Zahn #2	15-19 sec in Zahn #2	15-19 sec in Zahn #2
<b>Induction time</b>	30 minutes	2 hours at 55–70°F 1 hour at 71–80°F 30 minutes > 70°F	2 hours at 55–68°F 1 hour at 69–95°F
<b>Pot life</b>	8 hours at 70°F	4 hours at 70°F	4 hours at 70°F
<b>Flash off time</b>	None	30 minutes	30 minutes
<b>Dry time</b>	2 hours at 70°F 1 hour at 130°F	3 hours at 70°F 30 minutes at 120°F	3 hours at 70°F 30 minutes at 120°F
<b>Recoat window</b>	48 hours	48 hours	48 hours

\* Shelf life per manufacturer's recommendation.

**B. Chromate Primers**

	<b>44GN007*</b>	<b>10P20-44*</b>
<b>Manufacturer</b>	PPG	AkzoNobel
<b>Base</b>	44GN007	10P20-44
<b>Activator</b>	44GN007CAT	EC-265 or EC-273
<b>Reducer</b>	Distilled or deionized water	TR-114 or TR-102
<b>Base: Activator: Reducer</b>	3:1:8	3:1:1
<b>Viscosity</b>	18–22 seconds in Zahn #2	13–19 seconds in Zahn #2
<b>Induction time</b>	None	None
<b>Pot life</b>	4 hours at 70°F	4 hours at 77°F
<b>Flash off time</b>	15 minutes	30 minutes
<b>Dry time</b>	2 hours at 70°F 45 minutes at 120°F	30 minutes at 140°F
<b>Recoat window</b>	24 hours	24 hours

\* Shelf life per manufacturer's recommendation.

23-76 Powder Coat

PRODUCT	MANUFACTURER
Interpon 100-AL101QF Gray Zinc Rich Epoxy Powder*	AkzoNobel Santa Fe Springs, CA
81-2158 Vitralon Gray Zinc Rich Epoxy Powder*	Pratt & Lambert Chemical Coatings Buffalo, NY
39/80020 Smooth Matte Black Polyester Topcoat Powder*	Tiger Drylac USA Cucamonga, CA
49/72460 Smooth Glossy Gray RAL 7043 Polyester Topcoat Powder*	" "
49/22460 Smooth Glossy Yellow RAL 1028 Polyester Topcoat Powder*	" "
PFWF104S9 White Polyester Topcoat Powder*	Dupont Co. Wilmington, DE

\* Shelf life is 12 months from date of manufacture at ambient temperature.

Intentionally Blank

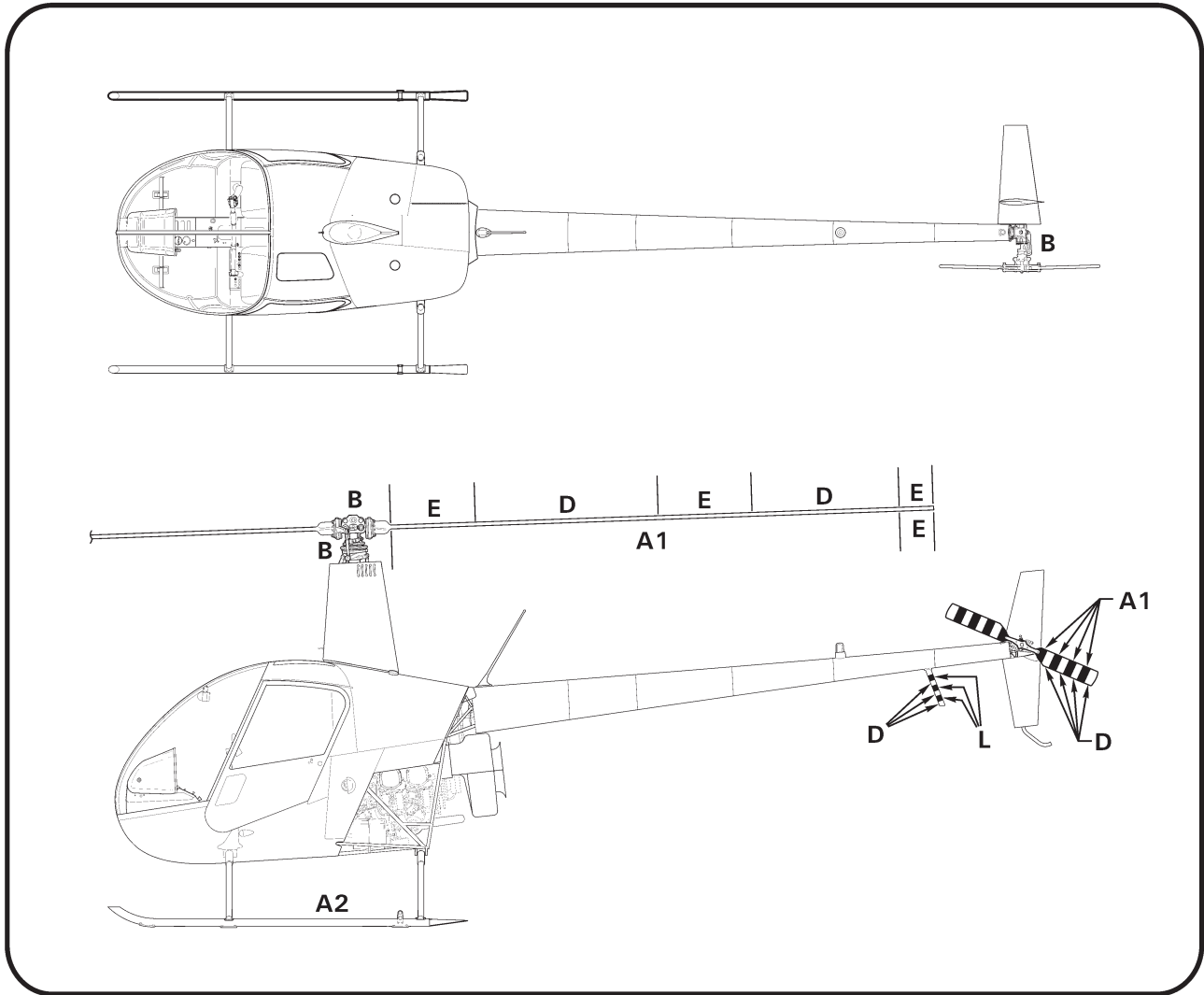

**FIGURE 23-12 PAINT CODES**

(Refer to Chapter 26 for rotor blade paint dimensions. Exterior surface codes are D & F unless otherwise specified.)

**23-77 Paints**

Refer to Figures 23-12 & 23-13 for paint code application. Paint codes for specific helicopter serial numbers are listed on the inside cover of Airframe Maintenance Record (logbook).

FINISH CODE	MATERIAL*	ADDITIVES	MANUFACTURER	RHC PART NO.	APPLICATION
<b>A1</b>	Flat Black 18BK006	18BK006CAT Catalyst	PPG Aerospace; Irvine, CA	18BK006	Blade black
	Abrasion Resistant 23T3-90 Black	PC-216 Curing Solution	AkzoNobel; Waukegan, IL	23T3-90	
<b>A2</b>	FR2-55 Mat Top Coat	Thinner: water	Mapaero Pamiers, France	557Z7038B005	Interior, skid tube, windshield, & window trim black
	Aerofine 8250 Topcoat	Thinner: water	AkzoNobel; Waukegan, IL	A8250	

23-77 Paints (continued)

FINISH CODE	MATERIAL *	ADDITIVES	MANUFACTURER	RHC PART NO.	APPLICATION
<b>A3</b>	Cardinal A-2000 Flat Black	/	Cardinal; Cleveland, OH	A2000-BKE-30-903	Interior, skid tube, windshield, & window trim Touch Up Aerosol
	Krylon 1613 Semi-Flat Black	/	Krylon; Columbus, OH	1613	
<b>B</b>	Dark gray Imron AF400/AF700	13100S Activator 13110S Activator	Axalta; Wilmington, DE	DS020EP	Dark grey
<b>D</b>	White Imron AF400/AF700	13100S Activator 13110S Activator	Axalta; Wilmington, DE	N0774EP	White
<b>E</b>	Yellow Imron AF400/AF700	13100S Activator 13110S Activator	Axalta; Wilmington, DE	N0680EP	Yellow
<b>F</b>	Imron AF400/AF700 Colors	13100S Activator 13110S Activator	Axalta; Wilmington, DE	/	Exterior
<b>G</b>	Clear Imron AF740	13100S Activator 13110S Activator 13930S Reducer	Axalta; Wilmington, DE	AF740	Clear coat
	1311 Matte Clear Coat	/	Krylon; Columbus, OH	1311	Clear coat aerosol
<b>J</b>	White Imron 2.1 FT	9T00 Activator D-121 Tint D-101 Tint 2100-P 2.1 Binder 9T20 Flattener	Axalta; Wilmington, DE	9T00-A D121 D101 2100-P 9T20	Floats
<b>K</b>	Printcolor White Ink 750-9005 Printcolor Black Ink 750-8005 Printcolor Maize Yellow Ink 750-1205 Printcolor Carnation Red 750-3005	Printcolor Glass Hardener 700 Gensolve Thinner GS-017L Slow Retarder 10-03432	Deco; Orance, CA	7509005 7508005 7501205, 7503005	Silkscreen
<b>L</b>	Red Imron AF400/AF700	13100S Activator 13110S Activator	Axalta; Wilmington, DE	N0759EP	Red
<b>O</b>	Light Gray Imron AF400/AF700	13100S Activator 13110S Activator	Axalta; Wilmington, DE	N0020	Baggage compartment
<b>P</b>	Silver Bullet AM Tracer Black 20-452AM-F1	16-CURE-F4 Activator	Burke; Ridgefield, WA	20-452AM-F1	R66 Middle seat
<b>Q</b>	ProtectaClear		Everbrite; Rancho Cordova, CA	Protecta	Optional on bare area of MR spar

\* Shelf life per manufacturer's recommendation.

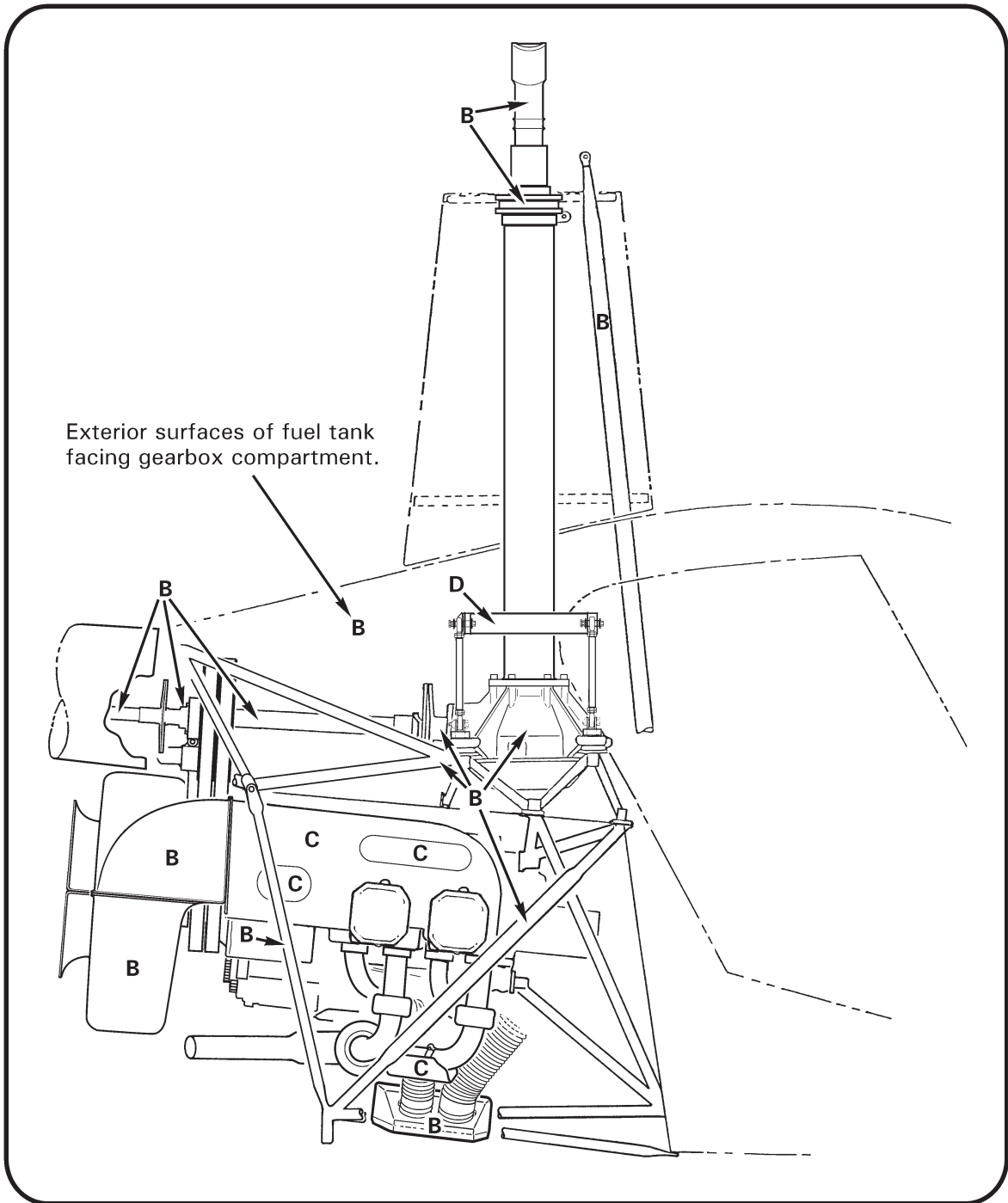

FIGURE 23-13 PAINT CODES



23-78 Lubricants

RHC PART NO.	LUBRICANT TYPE	MANUFACTURER'S PART NO.	MANUFACTURER
A257-1	Grease (general purpose)	101	Southwestern Petroleum Corp. Fort Worth, TX
A257-2	Gear oil	201 SAE 90	Southwestern Petroleum Corp. Fort Worth, TX
A257-3	Grease	Aero Shell 14 MIL-G-25537	Shell Oil Co.
A257-4	Oil (automatic transmission fluid)	Dexron II or Dexron II/Mercon or Dexron III/Mercon or Dex/Merc	Any
A257-6	Grease (fuel resistant)	Fuelube  EZ Turn	Fleet Supplies Inc. Cleveland, OH  United-Erie Div. of Interstate Chemical Co. Erie, PA
A257-7	Dry film lubricant	Lubri-Kote Type A 1040 CR	Mealey Ind. Lubricants Cleveland, OH
A257-8	Rubber lubricant	P-80	International Products Corp. Trenton, NJ
A257-9	Anti-seize	Silver Grade	Loctite Corp. Newington, CT
A257-10	Substitute A257-16		
A257-12	Grease	MobilGrease 28 MIL-PRF-81322	Exxon Mobil Corp., Fairfax, VA
A257-16	Engine Oil Approved for 0–90° F ambient). Substitute A257-24 as required.	SAE 20W-50, SAE J1966	Any
A257-17	Substitute A257-19		
A257-19	Valve lubricant and sealant compound	111	Dow Corning Corp. Midland, MI
A257-22	Gear oil, synthetic	Mobil SHC 629	Exxon Mobil Corp., Fairfax, VA
A257-24	Engine oil (Approved for > 60° F ambient)	SAE 50, SAE J1966	Any

23-79 Adhesives and Sealants

RHC PART NO.	DESCRIPTION	COLOR	MFR. PART NO.	MANUFACTURER
B270-1	Sealant – manganese-cured, fuel resistant (2-part)	Gray	AC-730 B-*	3M Co. St. Paul, MN
B270-2	Substitute B270-1			
B270-4	Substitute B270-13			
B270-5	Sealant – synthetic rubber putty (1-part)	White Light Gray	Q4-2805 94-031	Dow Corning Corp. Midland, MI
B270-6	Sealant & lubricant – thread (1-part)	Gray	80631, 80632, 80633	Permatex, Inc. Solon, OH
			Titeseal 55	Radiator Spec. Co. Charlotte, NC
B270-7	Substitute B270-14			
B270-8	Adhesive – rubber, nitrile/acetone (1-part)	Tan	C 160	Stabond Corp. Gardena, CA
		Dark Brown	847	3M Co. St. Paul, MN
B270-9	Adhesive – epoxy, structural, flexible (2-part)	Gray	2216 B/A	3M Co. St. Paul, MN
B270-10	Adhesive/sealant – threadlocker, anaerobic, tight-fits (1-part)	Red	271	Henkel Loctite Corp. Rocky Hill, CT
B270-11	Adhesive/sealant – threadlocker, anaerobic, loose-fits (1-part)	Red	277	Henkel Loctite Corp. Rocky Hill, CT
B270-12	Sealant – electrical potting (1-part epoxy)	Gray	50-3122RGR15 (1-qt can) 50-3122RGR33 (syringe)	Epoxies Etc., Cranston, RI
B270-13	Sealant – silicone rubber, noncorrosive (1-part)	Translucent	3145	Dow Corning Corp. Midland, MI
B270-14	Substitute B270-8			
B270-15	Adhesive – plastic, for vinyl (1-part)	Clear	2262	3M Co. St. Paul, MN
B270-16	Substitute B270-14			
B270-17	Adhesive – cyanoacrylate, instant (1-part)	Clear	Super Bonder 495	Henkel Loctite Corp. Rocky Hill, CT
B270-18	Adhesive – weatherstrip (1-part)	Black	051135-08008	3M Co. St. Paul, MN
B270-19	Adhesive – epoxy structural, rigid (2-part)	Green	1838 B/A	3M Co. St. Paul, MN
B270-20	Adhesive/sealant – threadlocker, anaerobic, non-permanent (1-part)	Purple	222 or 222MS	Henkel Loctite Corp. Rocky Hill, CT

23-79 Adhesives and Sealants (continued)

RHC PART NO.	DESCRIPTION	COLOR	MFR. PART NO.	MANUFACTURER
B270-21	Protectant – corrosion, non-drying (1-part)	Amber	Max Wax	Corrosion Technologies Corp. Garland, TX
		Lt. Amber	LPS 3	LPS Laboratories, Inc. Tucker, GA
B270-22	Substitute B270-21			
	Protectant – corrosion, drying (1-part)	Amber	LPS Hardcoat	LPS Laboratories, Inc. Tucker, GA
B270-23	Sealant – gasket (1-part)	Purple	515	Henkel Loctite Corp. Rocky Hill, CT
B270-24	Activator/primer – anaerobic adhesive (1-part)	Translucent Green	7649	Henkel Loctite Corp. Rocky Hill, CT
B270-25	Clear coat – automotive touch up, brush in bottle (1-part)	Clear	Clear Coat Touch up Bottle	Automotive Touchup Harahan, LA
B270-26	Sealant – polysulfide, window glazing (2-part)	Black	AC-251 B-1	3M Co. St. Paul, MN
B270-27	Adhesive – epoxy, high strength structural, flexible (2-part)	Translucent Red Blue	EA 9309NA EA 9309.2NA	Henkel Loctite Corp. Rocky Hill, CT
B270-28	Substitute B270-27			

\* Dash number for minimum hours application life may be -½, -2, -6, or -12.

## 23-80 Miscellaneous Practices

### 23-81 Part Interchangeability

Refer to R22 Illustrated Parts Catalog for part interchangeability information.

### 23-82 Thermal Fitting Parts

General Procedures for using heat to fit parts during assembly or evaluating parts that may have been overheated in service:

*Aluminum parts* must not be heated above 200° F for more than 5 minutes. Higher temperatures or longer times adversely affect strength and corrosion properties. Scrap any aluminum parts suspected of going above 325° F regardless of time at temperature.

*Steel parts (bare)* – Maximum temperature 300° F. Higher temperature can reduce the strength or cause temper brittleness in some alloys.

*Steel parts (cadmium plated)* – Maximum temperature 300° F. Higher temperatures will melt the plating and adversely affect steel strength by a process called liquid metal embrittlement.

*Bearings and carburized parts* such as gears, clutch shafts, and clutch housings should not be heated above 300° F. Higher temperatures will reduce the surface hardness and increase wear rates.

Always heat parts in an oven with temperature control set no greater than the maximum temperature allowed for the part.

Always attach a pyrometer and thermocouple to the smallest aluminum part in the oven. Never depend on the oven control to determine part temperature.

Cooling a part for thermal fitting at assembly is not recommended. Water vapor from the air will condense on the part and frequently introduce water into the assembly causing severe internal corrosion over time.

23-83 Replacement Component Identification (Data) Plates

In order to issue a replacement component identification plate for field installation, RHC must first receive the old identification plate in legible condition. If old identification plate is lost or destroyed, then RHC must have an original letter (photocopies or faxes are NOT acceptable) from customer's Civil Aviation Authority (sent via postal mail, or via electronic mail directly from authority domain, such as "faa.gov") authorizing identification plate replacement AND stating component name, part number, and serial number for each requested identification plate. There is a charge for each plate issued.

Identification plates may be carefully removed using a sharp plastic scraper. If necessary, use a heat gun to soften plate adhesive. Retain in a dry, contaminate-free area until ready for reinstallation.

Damp wipe local area with acetone or equivalent solvent prior to reinstallation. Residual adhesive on identification plate is usually sufficient for good adhesion. If necessary, use B270-9 adhesive or equivalent to secure.

23-84 Crimp Inspection

Refer to Figure 23-14.

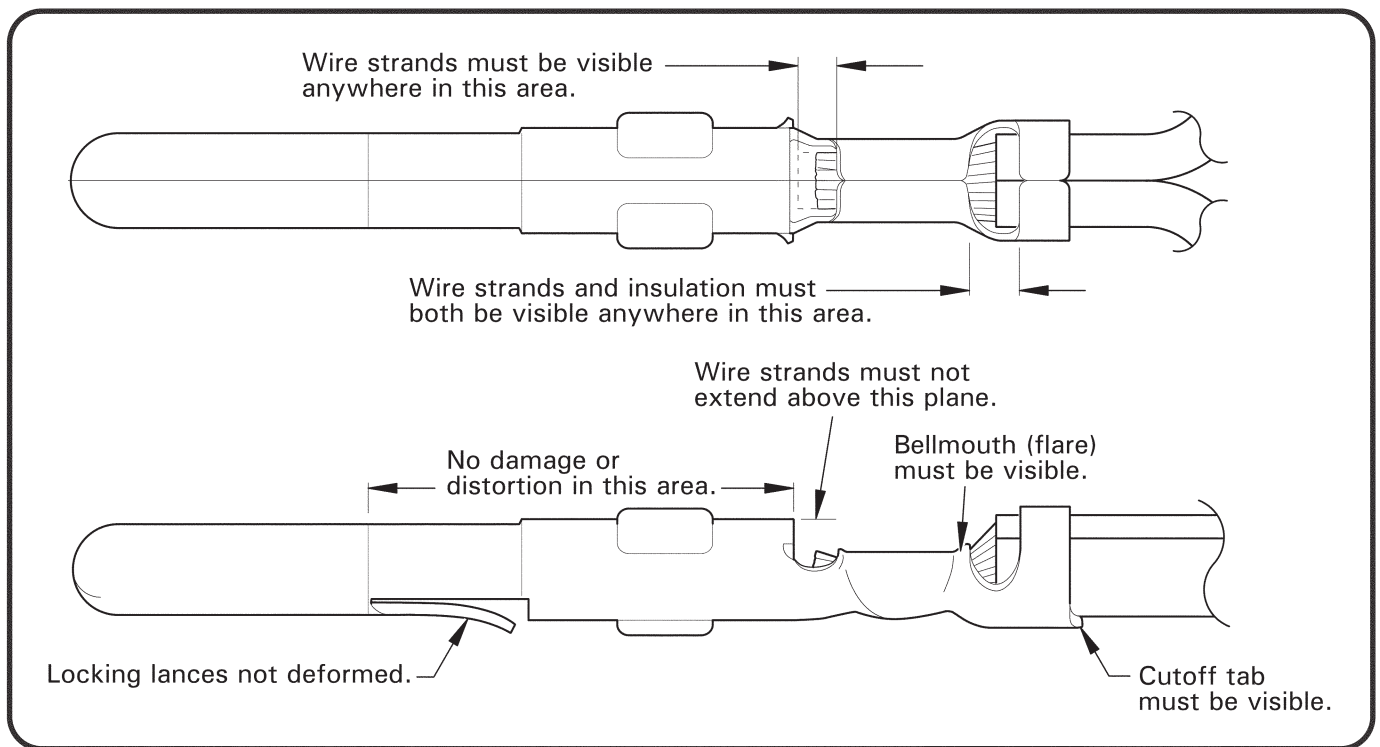

**FIGURE 23-14 CRIMP INSPECTION**

23-85 Storage Limits

1. B283 hoses have a shelf storage life of 5 years. Hose service life is "on condition", with a maximum of 12 years.
2. Elastic cords have a shelf storage life of 5 years. Elastic cord service life is "on condition", with a maximum of 12 years. Use invoice or FAA Form 8130 date as start date.
3. Store V-belts at less than 85° F (30° C), with relative humidity below 70%. Avoid solvent and oil vapors, atmospheric contaminants, sunlight, and ozone sources (electric motors, arc welding, ionizing air purifiers, etc.). Belt shelf life is 4 years if preceding recommendations are followed. Use invoice date or FAA Form 8130 date as start date.
4. Oils and greases have a 5 year shelf life when stored and kept sealed in their original container. Use invoice date or FAA Form 8130 date as start date unless the manufacturer has marked container with manufacture date (in which case use manufacture date as start date).
5. Rubber o-rings, seals, and gaskets have a twenty (20) quarter, five (5) year shelf life from the indicated cure date. Fluorocarbon (Viton) and silicon rubber products shall adhere to manufacturer's expiration date(s). Service life is "on condition" with a maximum of 12 years.
6. Store uninstalled fuel bladder in original container (if available) at 70°F to 80°F and below 70% humidity. Coat bladder with clean, non-detergent engine mineral oil to prevent rubber from drying out and cracking. Store bladder in relaxed condition free from tension, compression, or other deformation such as creases or folds.

23-86 B526 Screws and B527-08 Washers

B526 (TORX Plus®) truss head screws may be used to secure cowlings and access panels. A B527-08 nylon washer may be used under a B526 screw head to further protect thin or painted surfaces.

B526 screws are interchangeable with MS27039C080\_ screws used to secure cowlings and access panels as follows:

<u>PART:</u>	<u>INTERCHANGEABLE WITH:</u>
MS27039C0806 screw . . . . .	B526-6 screw
MS27039C0807 screw . . . . .	B526-8 screw
MS27039C0808 screw . . . . .	B526-8 screw

B526 screws are interchangeable with AN525-832R\_ & AN526C832R\_ screws as follows:

<u>PART:</u>	<u>INTERCHANGEABLE WITH:</u>
AN525-832R6 or AN526C832R6 screw . . . .	B526-6 screw
AN525-832R7 or AN526C832R7 screw . . . .	B526-8 screw
AN525-832R8 or AN526C832R8 screw . . . .	B526-8 screw

**NOTE**  
B526 screws are compatible with T20 or 20IP drivers.