

**R22-series & R44-series Cylinder Head Temperature (CHT) Gage Calibration Kit Instructions**

*Kit installs C691-1 circuit board assembly on B144-3 or -4 instrument cluster. Refer to R22 Service Letter SL-73 and R44 Service Letter SL-59.*

**NOTE**

Visit [www.robinsonheli.com](http://www.robinsonheli.com) to verify kit instructions are current revision. Review instructions before installation; contact RHC Technical Support with questions. Verify kit contents match list; contact RHC Customer Service if parts are missing or damaged.

ITEM	PART NUMBER	KIT CONTENTS	QTY
1	KI-249Instr.	Kit Instructions . . . . .	1
2	A701-1.5FT	Tape – 1-inch wide (5-foot roll) . . . . .	1
3	B161-4-12	Spirap – 1/4-inch diameter (1-foot length) . . . . .	1
4	B263-2	Socket . . . . .	1
5	B263-11	Housing (1-socket) . . . . .	1
6	B330-7	Palnut . . . . .	1
7	C691-1	Circuit Board Assembly . . . . .	1
8	MS3367-4-9+	Ty-rap (Note: “+” in part number indicates 20-qty pack) . . . . .	1
9	NAS620-10L+	Washer (Note: “+” in part number indicates 20-qty pack) . . . . .	1

**Special Tools**

- Calibrated multimeter
- Wire insulation stripper
- Pin/socket crimper
- Resistance decade box, or 32.0 ±0.4 ohm resistor

**Kit Instructions**

1. Ensure BATTERY switch is off. Pull all circuit breakers.
2. Gain access to back side of CHT gage in B144 instrument cluster. Lay a towel across vertical panels below instrument cluster to catch any dropped hardware.
3. Disconnect -34 wire from “SEND” terminal post of CHT gage, retaining lockwasher and brass nut. Cut and discard ring terminal from -34 wire.
4. Disconnect -569 wire from CHT “IGN” terminal post, retaining lockwasher and brass nut.
5. Refer to Figure 1. If instrument cluster wiring is routed between CHT gage “SEND” and “IGN” posts, install a one-inch length of B161-4 spirap on wiring between posts as shown.

**Kit Instructions (continued)**

6. Install C691-1 circuit board assembly with:

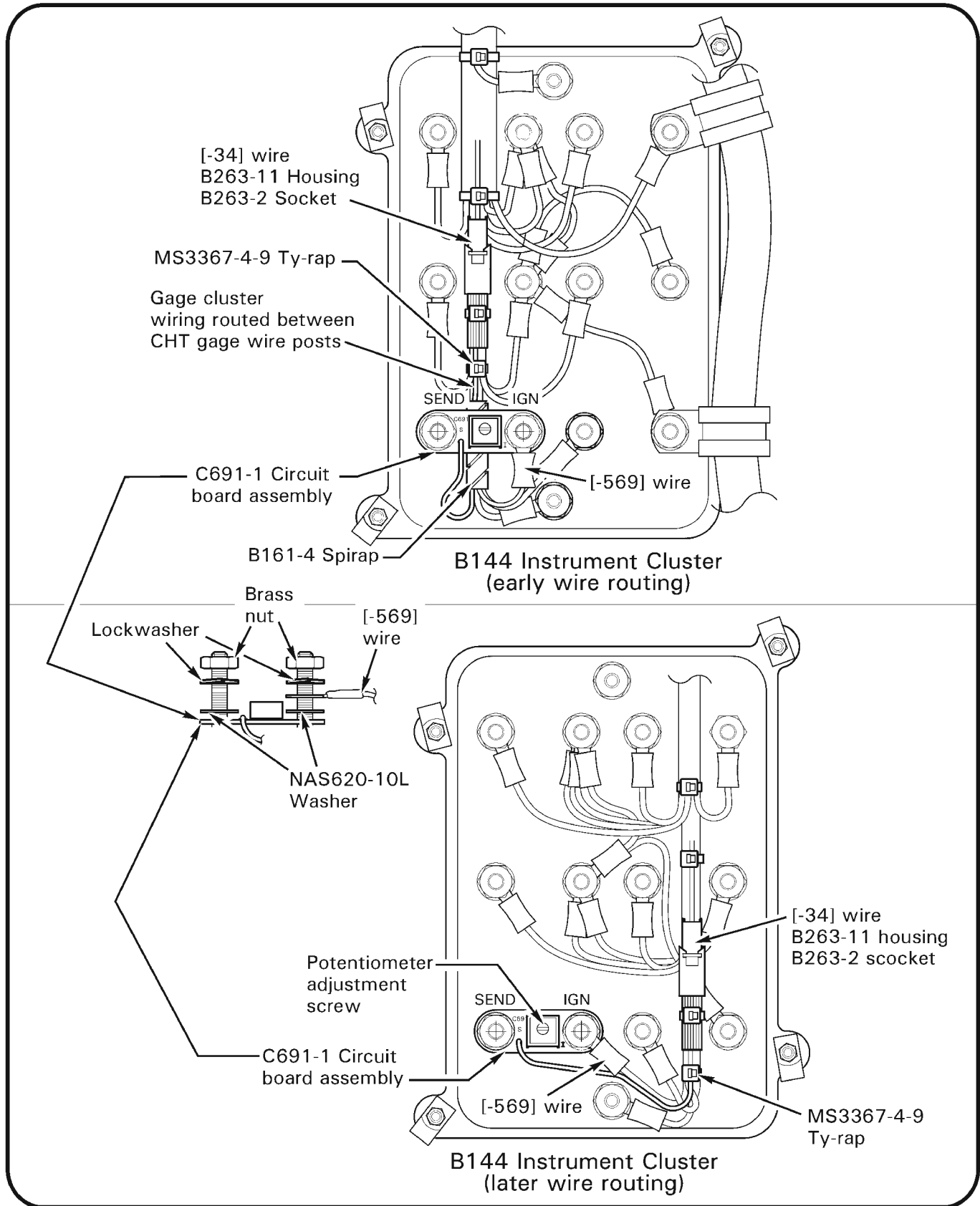
- wire attached to circuit board routed per applicable view in Figure 1.
- hole marked “S” on CHT gage “SEND” terminal post.
- hole marked “I” on CHT gage “IGN” terminal post.
- potentiometer adjustment screw accessible as shown.

Install NAS620-10L washer, lockwasher, and brass nut on “SEND” terminal post. Install NAS620-10L washer, -569 wire, lockwasher, and brass nut on “IGN” terminal post. Torque both brass nuts to 15 in.-lb. Verify security.

**NOTE**

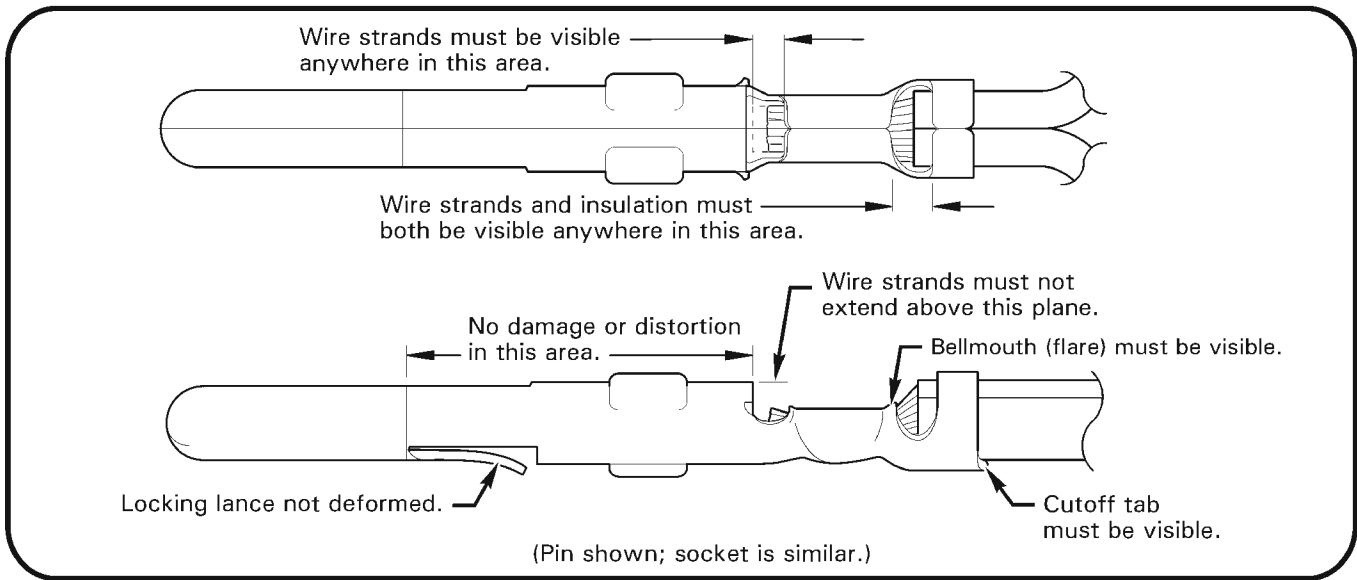
Palnuts on instrument cluster wire terminals are no longer required. Previously installed palnuts may be discarded provided remaining primary nuts are checked for security.

7. Trim original -34 wire to result in final installation per Figure 1, strip insulation, and crimp B263-2 socket on wire. Inspect crimp per Figure 2. Install B263-11 housing and verify socket security. Connect original -34 wire to wire from C691-1 circuit board (a “click” sound is heard when socket/housing are fully mated.) Route and secure wiring with MS3367-4-9 ty-raps as required; cinch ty-rap until snug without over tightening, and trim tip flush with head.
8. Gain access to engine-mounted CHT probe and disconnect -34 wire from probe, retaining removed brass nut (one brass nut remains on probe.)
9. Refer to Figure 3. Adjust resistance decade box to  $32 \pm 0.4$  ohms and verify resistance with multimeter. Alternately, a  $32.0 \pm 0.4$  ohm resistor may be used instead of decade box. Connect a low-impedance (<1 ohm) test lead to one terminal on decade box and clamp opposite end of lead to hexagonal body of CHT probe; do not connect lead to center conductor of probe. Connect -34 wire to remaining terminal on decade box.
10. Refer to Figure 4. Push in “GAGES” and “WARN LTS” circuit breakers. Switch “BATTERY” on and observe CHT gage. Adjust potentiometer screw on C691-1 circuit board assembly until gage indicates within limits shown with console in closed position (CHT probe resistance is  $32 \pm 0.4$  ohms at 500° F).
11. Cut small square of A701-1 aluminum tape sized to fit potentiometer face. Apply tape to potentiometer and press tape tight against adjustment screw to prevent rotation (pressing with a pencil eraser works well). Verify CHT needle has not moved. If movement is noted, remove tape and repeat step 10 as required. Switch “BATTERY” off.
12. Close and secure instrument console. Push in all remaining circuit breakers.
13. Disconnect resistance decade box (or resistor) and test lead from helicopter. Connect -34 wire to CHT probe with ring terminal between brass nuts. Install B330-7 palnut. Verify security.
14. Make appropriate maintenance record entries. No change to helicopter weight and balance.

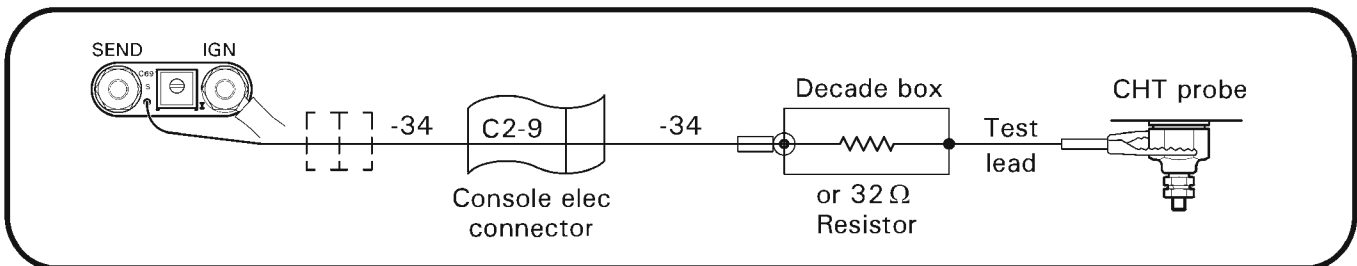


**FIGURE 1**  
(back view)

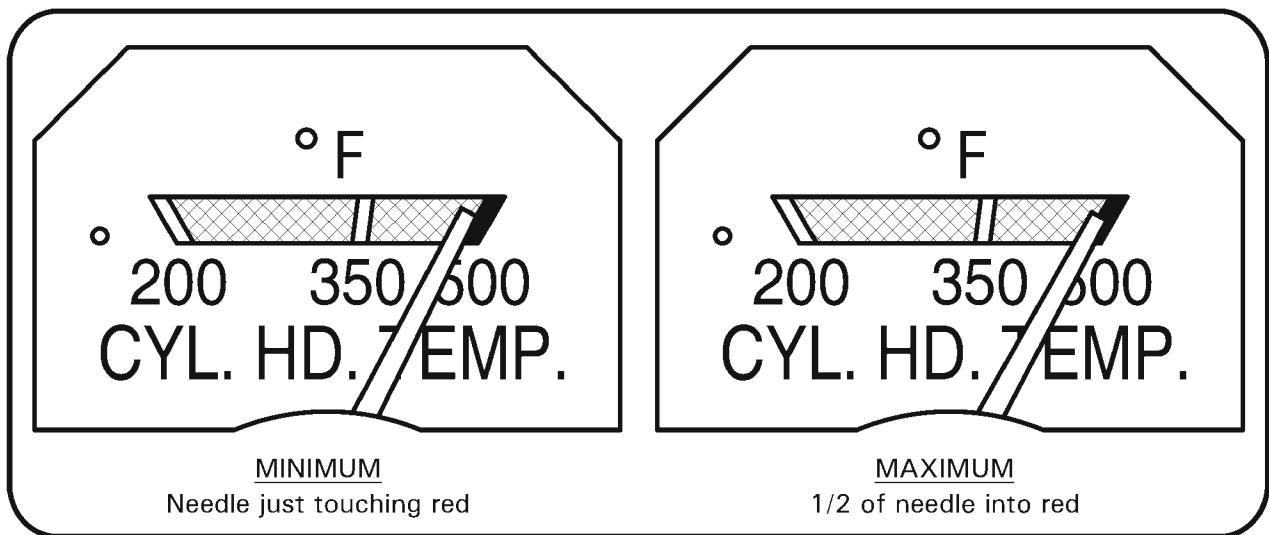
**Kit Instructions (continued)**



**FIGURE 2**



**FIGURE 3**



**FIGURE 4**