

R44-series Bladder Fuel Tank Installation Kit Instructions

For compliance with R44 Service Bulletin SB-78B & SB-84. Helicopter must be equipped with D743-3 aux fuel pump (R44 II only). Previous compliance with R44 Service Bulletins SB-67 and SB-69 required. This kit meets the standards of Section 317 of the FAA Reauthorization Act of 2018 (see: FAA SAIB SW-17-31R2).

NOTE

Visit www.robinsonheli.com to verify kit instructions are current revision. Review instructions before installation; contact RHC Technical Support with questions. Verify kit contents match list; contact RHC Customer Service if parts are missing or damaged.

CAUTION

If interference is encountered with any aspect of this installation, contact RHC Technical Support for guidance before proceeding.

NOTE

If aircraft is equipped with C259-5 & -6 cabin bulkhead stiffeners, C003-2 or -18 aft cabin foam insulation will be removed. Order new foam as required; reuse of foam is not recommended.

NOTE

Rivets included in kit contents are provided as a courtesy and at lengths most commonly used on production helicopters. Proper rivet length is determined by installer during installation.

ITEM	PART NUMBER	KIT CONTENTS	(R44) QTY PER KI-196-1	(R44 II) QTY PER KI-196-2
1	KI-196Instr.	Kit Instructions	1	1
2	A226-11-3	Trim (3 inch length)	1	1
3	A226-15-1.6	Trim (1.6 inch length)	1	1
4	A701-1.5FT	Aluminum Tape - 1 inch wide (5 foot length)	1	1
5	A729-17	Tube - Drain	1	1
6	A729-63	Tube	2	2
7	A729-79	Tube	2	2
8	A731-10	Tube Assembly	1	1
9	A738-7	Gang Channel	1	1
10	A761-1	Drain Valve Assembly	1	1
11	A880-536	Adapter (CRES; alternate p/n A880-566, steel)	2	1
12	A880-736	Elbow (CRES; alternate p/n A880-766, steel)	1	0
13	A880-836	Elbow (CRES; alternate p/n A880-866, steel)	0	2
14	A880-1003	Nut (drain)	1	1
15	A880-1136	Tee (CRES; alternate p/n A880-1166, steel)	1	0
16	B161-4-12	Spirap - 0.25 inch diameter (12 inch length)	2	2

ITEM	PART NUMBER	KIT CONTENTS (Cont'd)	(R44) QTY PER KI-196-1	(R44 II) QTY PER KI-196-2
17	B277-4	Clamp	2	2
18	C010-6	Fuel Tank Assembly - Main	1	1
19	C130-17	Spacer	1	1
20	C141-5	Washer	0	1
21	C595-2	Hose Assembly (tank interconnect)	1	0
22	C595-3	Hose Assembly (tank interconnect)	0	1
23	C595-4	Hose Assembly (relief valve-to-tee)	0	1
24	C654-3	Decal	1	1
25	C654-4	Decal	1	1
26	C654-5	Decal	1	1
27	C654-6	Decal	1	1
28	D042-4	Door Assembly - Small	1	1
29	D043-5	Fuel Tank Assembly - Aux	1	1
30	D205-30	Hose Assembly (main tank sump drain)	1	1
31	D205-38	Hose Assembly (tank-to-valve)	1	1
32	D251-1	Valve Assembly - Rollover	2	2
33	D255-1	Connector - Drain	1	1
34	D255-2	Angle - Drain Bracket	1	1
35	D255-5	Support	1	1
36	D277-6	Clamp	4	4
37	D319-4	Fitting	0	1
38	D453-4	Tee	0	1
39	D453-5	Jet (black; 0.128–0.130 inch diameter bore)	0	1
40	D663-1	Clamp	1	1
41	D682-44	Decal	2	2
42	D819-1	Decal	1	1
43	D819-2	Decal	1	1
44	F654-13	Decal	1	1
45	MT106-3	Tube	1	1
46	MS20426AD3-3+	Rivet (Note: "+" in part number indicates 50-qty pack)	1	1
47	MS20470AD3-2.5+	Rivet (Note: "+" in part number indicates 50-qty pack)	1	1
48	MS20470AD3-3.5+	Rivet (Note: "+" in part number indicates 50-qty pack)	1	1
49	MS20615-3M3+	Rivet (Note: "+" in part number indicates 20-qty pack)	1	1
50	MS20615-4M4+	Rivet (Note: "+" in part number indicates 10-qty pack)	2	2
51	MS21042L08	Nut	7	7
52	MS21069L08	Nutplate	7	7
53	MS21919WDG3	Clamp	0	1
54	MS21919WDG14	Clamp	1	1

ITEM	PART NUMBER	KIT CONTENTS (Cont'd)	(R44) QTY PER KI-196-1	(R44 II) QTY PER KI-196-2
55	MS27039C0806	Screw	1	1
56	MS27039C0821	Screw	1	1
57	MS29512-06	Packing	0	3
58	MS3367-4-9+	Ty-rap (Note: "+" in part number indicates 20-qty pack)	1	1
59	MS3367-5-9+	Ty-rap (Note: "+" in part number indicates 20-qty pack)	2	2
60	MS3367-6-0	Ty-rap	1	1
61	MS35489-6	Grommet	3	3
62	NAS1149FN816P+	Washer (Note: "+" in part number indicates 20-qty pack)	1	1
63	NAS1149F0632P+	Washer (Note: "+" in part number indicates 20-qty pack)	1	1

Consumables

Refer to R44 Maintenance Manual (MM) § 1.400 for approved materials list.

- A257-6 Grease
- B270-1 Sealant
- B270-6 Sealant
- Bonderite M-CR 1132 (Alodine 1132), or Bonderite M-CR 1201 Aero (Alodine 1201)
- Epoxy primer

Kit Instructions

CAUTION
Temporarily cap fuel fittings when opened.

WARNING
Fuel vapors are explosive. Do not use electric tools in vicinity of an opened fuel system.

1. Review instructions before installation. Contact RHC Technical Support if you have questions.
2. Perform R44 Service Bulletin SB-67 and SB-69, if not previously accomplished.
3. Turn battery switch off. Remove mast fairing, tailcone cowling, left, right, & aft cowlings, aft belly panel, C474 trim & cover between aft seat backs, and left & right aft seat back assemblies. R44 II only: remove air box assembly.
4. Refer to R44 Illustrated Parts Catalog (IPC) Figure 28-5. Cut & discard safety-wire securing (3) A729 yellow vent tubes (and internal springs) to C731-2 vent lines and discard tubes and springs. Remove & discard (2) MS21919WDG4 clamps and hardware securing vent lines to middle rib. Cut & discard ty-raps securing vent lines to pitot line. Slowly pull vent lines thru lower rib grommets and remove vent lines; discard vent lines.
5. Remove main & auxiliary tanks (non-bladder) per MM § 12.111 & 12.121. Remove D042-5 door assembly. Remove and discard A226-11 trim, 2 places (see IPC Figure 28-5, Detail C).

Kit Instructions (continued)

6. For helicopters that have complied with R44 Service Bulletin SB-68, remove and discard D205-26 or -28 (tank-to-valve), D205-27 or -29 (tank-interconnect), and D205-31 or -26 (relief valve-to-tee, R44 II only) hose assemblies. Thoroughly clean horizontal firewall. Proceed to step 8.
7. For helicopters that have not complied with R44 Service Bulletin SB-68, remove and discard C726-2 (tank-to-valve), C726-1 (tank-interconnect), and C726-7 (relief valve-to-tee, R44 II only) line assemblies. Thoroughly clean horizontal firewall. Perform the following steps:
 - a. Refer to Figure 1. Lay out hole locations on C351-1 brace. Drill two 0.170-inch diameter holes and deburr. Clean up debris.
 - b. Refer to Figure 2. Between aft seats, remove two MS21919WDG clamps (if installed) and hardware securing static line and horizontal wire bundle to vertical firewall. Discard clamps and screw. If required, lay out hole location on C233-1 vertical firewall and drill 0.170-inch diameter hole; deburr hole and clean up debris.
 - c. Move static line to wire bundle, install MS21919WDG-8 thru -16 clamp (as required to eliminate play within harness, included -14 clamp is typical) with noted hardware. Install MS3367-5-9 ty-raps on static line and wire bundle as required.
 - d. Clean junction of C351-1 brace & C259-1 panel with solvent, and wrap two layers A701-1 aluminum tape around vertical corner. Press tape smooth.
8. Refer to Figure 1. Install A226-15-1.6 trim on bulkhead lip.
9. R44 II only: Refer to Figure 3. Disconnect B283-11 hose assembly at connector under horizontal firewall. Do not loosen relief valve at connector. Remove AN316-7R nut and NAS1149F0732P washer; retain nut & discard washer. Position relief valve (at loosened connector) so relief valve fitting points $55^{\circ} \pm 5^{\circ}$ aft; install C141-5 washer (provided) & retained nut and special torque AN316-7R nut to 150 in.-lb. Connect B283-11 hose assembly, special torque to 140 in.-lb, and torque stripe both nuts per MM Figure 2-1.
10. Refer to Figure 4 and IPC Figure 25-25. If aircraft is equipped with C259-5 (LH) and -6 (RH) cabin bulkhead stiffeners, remove C003-2 or -18 foam insulation by hand and remove remnants using non-metallic scraper. Drill out rivets securing C259-5 & -6 stiffeners and C435-3 channel to bulkhead; remove and discard stiffeners and channel. Remove residual sealant from bulkhead panels. Install MS20470AD3-2.5 rivets in holes previously used by stiffener and channel rivets.
11. Drill out rivets securing C384-3 (forward, LH) stiffener to horizontal firewall. Remove and retain stiffener. Remove residual sealant from firewall and stiffener and thoroughly clean underside of firewall.
12. Refer to Figure 5, Detail A. Cleco (sheet metal fastener) retained C384-3 (forward, LH) stiffener to underside of horizontal firewall as shown. Progressively remove clecos and install (15) MS20615-3M3 rivets. Verify stiffener security.
13. Refer to Figure 4, Detail A. Lay out hole locations in C259-1 (LH) bulkhead panel. Drill four 0.130-inch diameter holes and deburr.

Kit Instructions (continued)

NOTE

After trimming or filing aluminum, finish edges as follows: Deburr trimmed edges with 220-grit or finer wet-or-dry aluminum oxide abrasive paper. Solvent-clean deburred edge and apply Bonderite M-CR 1132 (Alodine 1132), or Bonderite M-CR 1201 Aero (Alodine 1201) in accordance with manufacturer's instructions. Apply epoxy primer to dry edge. Touch-up with helicopter paint color, where applicable, is optional.

14. Refer to Figure 4, Detail B. Lay out cut-away dimensions in C385-1 doubler. Cut 1.80-inch notch in doubler and rework vertical flange as shown. Remove hardware securing upper frame to C259-1 bulkhead and/or horizontal firewall, as required. Finish reworked edges per above NOTE. Apply B270-1 sealant to cover edge of reworked notch as shown. Install removed hardware as required, standard torque bolts per MM § 1.320, and torque stripe per MM Figure 2-1.
15. Refer to Figure 4, Detail C. Lay out hole location in C234-1 horizontal firewall (forward). Drill 0.170-inch diameter hole and deburr.
16. Refer to Figure 4, Detail D. Lay out hole location in C385-1 doubler. Drill two 0.170-inch diameter holes and deburr. Install A226-11-3 trim on doubler, centered above drilled holes as shown.
17. Refer to Figure 4, Detail E. Lay out hole locations in C259-2 (RH) bulkhead panel. Using new D255-2 angle as template, drill two 0.10-inch diameter holes and deburr.
18. Clean up drilling and cutting debris.
19. Refer to Figure 5, Detail B. Install D255-5 support using (1) MS27039C0806 screw, (1) NAS1149FN816P washer, and (1) MS21042L08 nut to horizontal firewall.
20. Refer to Figure 5, Detail C. Cleco new D255-2 angle to C259-2 (RH) bulkhead panel. Progressively remove clecos and install (2) MS20470AD3-3.5 rivets. Verify angle security.
21. Refer to Figure 6, Detail C & D. Draw longitudinal lines from center of (3) bulkhead channel nut holes onto exterior skins, on both sides of helicopter, as shown (noted channel nut holes are not accessible from inside cabin). Measure and record distances.
22. On underside of new C010-6 main fuel tank, loosen (6) screws securing D248-8 angle to tank and slide angle to forward-most position. Tighten screws.
23. Refer to Figure 6, Detail A. Mark main fuel tank bottom flange with a line, 0.32 inch below and parallel to, tank skin edge as shown.
24. Position main fuel tank in helicopter. Tank bottom flange (forward corner) must be between exterior skin and horizontal firewall flange. Lower edge of tank aft vertical panel must be between upper frame tabs and horizontal firewall flange; panel edge must be flush or below frame tab bottom edge.
25. Refer to Figure 6, Detail A. Align marked line with rearmost channel nut on horizontal firewall flange; align aft panel of tank with intermediate bulkhead per Detail B. Secure tank position by clamping vertical panel to frame tabs.

Kit Instructions (continued)

26. Install aft cowling assembly; install left cowling assembly, but do not install top row of screws. Adjust tank position as required for approximately 0.020 inch gap between tank exterior skin and left cowling upper edge.
27. Refer to Figure 6, Detail D. Estimate material to be removed for fitting tank forward edge with cabin exterior skin aft edge; file or cut tank forward edge to create a gap of no more than 0.065 inch between tank and skin.
28. Finish trimmed edge per NOTE on page 5 of kit instructions.

CAUTION

Forward edge of tank must be fitted and finished before proceeding to next step.

NOTE

To drill 0.170-inch diameter (#18) hole over installed nutplate, first drill 0.098-inch diameter (#40 drill with stop) hole at marked location (drill will not damage nutplate threads if marks are accurate). Adjust hole position as necessary by drilling 0.130-inch diameter (#30 drill with stop) hole through top material. Ream 0.170-inch diameter hole through top material.

29. From inside cabin, begin at the lowest nutplate and drill a 0.170-inch hole through tank skin (using existing nutplate as drill guide), and install cleco. Moving upward, repeat step for remaining nutplates.
30. Refer to Figure 6. Transfer longitudinal lines and recorded distances from exterior skin to tank forward edge, and lay out (3) drill marks. Using a drill stop, drill 0.170-inch holes through tank skin.
31. From inside cabin, gently lift foam and match-drill 0.170-inch holes in D248-8 angle through four holes in C259-1 bulkhead panel.

CAUTION

Protect drive belts from drilling debris.

32. Match-drill 0.170-inch holes in tank aft vertical panel through (3) holes in intermediate bulkhead. Match-drill 0.250-inch holes in panel through upper frame tab holes; temporarily install bolts.
33. Using a drill stop, progressively match-drill and cleco 0.170-inch holes in tank lower flange, on marked line, through left cowling upper holes.
34. Refer to Figure 7, Detail A. Mark horizontal centerline of new D043-5 aux tank channel doubler.
35. Position aux tank in helicopter. Align marked line with center of upper frame attachment hole as shown in Figure 7, Detail A; align fuel tank exterior skin aft edge with aft edge of latched D042-4 door assembly per Detail B. Secure tank position by clamping channel to frame at attachment hole.

Kit Instructions (continued)

36. Refer to Figure 6, Detail D. Estimate material to be removed for fitting tank forward edge with cabin exterior skin aft edge; file or cut tank forward edge to create a gap of no more than 0.065 inch between tank and skin.
37. Finish trimmed edge per NOTE on page 5 of kit instructions.

CAUTION

Forward edge of tank must be fitted and finished before proceeding to next step.

38. From inside cabin, begin at the lowest nutplate and drill a 0.170-inch hole through tank skin (using existing nutplate as drill guide), and install cleco. Moving upward, repeat step for remaining nutplates.
39. Transfer longitudinal lines and recorded distances from exterior skin to tank forward edge, and lay out (3) drill marks. Using a drill stop, drill 0.170-inch holes through tank skin.
40. Match-drill 0.250/0.256-inch hole in fuel tank channel through upper frame attachment hole; temporarily install bolt.
41. Refer to Figure 7. Open D042-4 door. Using a drill stop, match-drill 0.170-inch holes in C259-2 bulkhead panel through (4) holes in D253-3 angle. Close and latch door.
42. Install D042-5 door assembly and (2) aft screws securing door to intermediate bulkhead, and latch door. Adjust door position for no more than 0.050-inch gap between door forward edge and tank skin aft edge; simultaneously adjust door vertically to match fuel tank contour. Lay out hole location on C245-8 clip and verify drill hole on clip will have minimum 0.12-inch edge distance. Match-drill 0.170-inch hole in clip through door; install and secure screw.
43. Match-drill 0.170-inch holes in tank channel through (3) holes in D042-5 door assembly.
44. Refer to Figures 6 & 7. Cleco C347-1 channel to cabin. Match-drill 0.170-inch holes in main and aux tank inboard flanges through (2) remaining holes in channel.
45. Refer to IPC Figure 29-3. Position C347-6 panel between tanks and temporarily install spacers and bolt through D202-4 bracket and aft servo. Position aft servo C130-14 spacer 1.10 inch (C006-6 & prior gearboxes) or 0.90 inch (C006-7 & subsequent gearboxes) aft from mast tube and clamp panel to tanks. Match-drill 0.170-inch holes in tank inboard flanges through (2) forward holes in panel, and install clecos. Using a drill stop, match-drill 0.170-inch holes in tank inboard flanges through (4) remaining holes in panel, and install clecos.
46. Cleco C706-1 tailcone cowling to helicopter. Match-drill 0.170-inch hole in main tank aft flange through remaining hole in tailcone cowling. Remove tailcone cowling.
47. Remove clecos and hardware securing tanks to helicopter and remove tanks. Deburr new holes in fuel tanks and on helicopter. Clean up drilling and cutting debris.
48. Install (7) MS21069L08 nutplates on main and aux tank flanges as noted in Figure 7.

Kit Instructions (continued)

49. Refer to Figure 9. Install A738-7 gang channel on aft side of main fuel tank D248-8 angle using (2) MS20426AD3-3 rivets, countersunk heads forward.
50. Connect new D205-30 hose assembly to main tank drain union. Special torque hose nut to 100 in.-lb and torque stripe per MM Figure 2-1.
51. Route hose assembly (drain) thru notch in C385-1 doubler and position main fuel tank in helicopter. Verify hose is not pinched. Install screws securing tank to cabin bulkhead and horizontal firewall.
52. Install (2) aft bolts securing main tank to horizontal firewall and upper frame. As required, install (maximum 2) NAS1149F0432P and/or NAS1149D0416J washers between frame and tank to fill gap at each bolt. Standard torque bolts per MM § 1.320 and torque stripe per MM Figure 2-1.
53. Install (3) aft screws securing main tank to intermediate bulkhead.
54. From aft left seat, gently lift foam and install (4) screws securing main tank to cabin bulkhead.
55. Refer to Figure 9. Connect new D205-38 hose assembly to main tank outlet (forward fitting) and fuel shut-off valve. Special torque hose nuts to 120 in.-lb and torque stripe per MM Figure 2-1. Install MS3367-5-9 ty-rap around hose thru drilled holes in C351-1 brace (Figure 1). Cinch ty-rap until snug without over-tightening, and trim tip flush with head.
56. Refer to Figure 5, Detail D. Install new A880-1003 nut, NAS1149F0632P washer, and D255-1 connector in D255-2 angle as shown, and special torque nut to 100 in.-lb. Apply B270-6 sealant sparingly to new A761-1 drain valve tapered threads (do not apply sealant to first thread) and connect valve to connector. Hold connector, special torque valve to 60 in.-lb, and torque stripe per MM Figure 2-1. Install A729-17 tube and D663-1 clamp.
57. Refer to Figure 9. Install (1) B161-4-12 spirap around D205-30 hose assembly on left-side, to cover three inches of hose; trim spirap. Install (1) B161-4-12 spirap around D205-30 hose assembly on right-side, to cover six inches of hose; trim spirap. Connect D205-30 hose to bulkhead-mounted D255-1 connector (Figure 5, Detail D). Special torque nut to 100 in.-lb, and torque stripe per MM Figure 2-1. Secure D205-30 hose at left side to D255-5 support per View A-A, and at right side to C385-1 doubler flange per View B-B. Cinch ty-raps until snug without over-tightening, and trim tip flush with head.
58. Refer to Figures 9 and 10, View A-A. Connect new C595-2 (R44) or C595-3 (R44 II) hose assembly to main tank A880-936 union. Special torque hose nut to 120 in.-lb and torque stripe per MM Figure 2-1. Temporarily cap open end of hose assembly.
59. Position aux tank in helicopter and install screws securing tank to cabin bulkhead.
60. Install aft bolt securing aux tank channel to upper frame. Standard torque bolt per MM § 1.320 and torque stripe per MM Figure 2-1 (palnut not required).
61. From aft right seat, gently lift foam and install (4 each) screws, nuts, and washers securing aux tank to cabin bulkhead.

Kit Instructions (continued)

62. I. R44 only: Refer to Figure 9.

- a. Remove temporary cap on C595-2 hose assembly and connect elbow to aux tank outlet fitting; special torque to 120 in.-lb, and torque stripe per MM Figure 2-1. Secure hose per View A-A; cinch ty-raps until snug without over-tightening, and trim tips flush with head.
- b. Remove and discard blue, aluminum AN823-6D elbow from carburetor fuel inlet. Apply light coat B270-6 sealant to A880-736 elbow (do not apply sealant to first thread), and install in carburetor. Standard torque elbow [1/4-18 tapered pipe thread] per MM § 1.320 and apply torque stripe per MM Figure 2-1. Connect B283-3 hose assembly and special torque 120 in.-lb.
- c. Drain and remove A666-1 gascolator. Remove blue, aluminum fittings from gascolator top. Apply light coat B270-6 sealant to A880-536 adapter (do not apply sealant to first thread) and install in inlet (engraved "IN") port on A666-1 gascolator; repeat procedure for gascolator outlet and install either A880-1136 tee (if optional primer installed), or A880-536 adapter. Standard torque adapter(s) & tee [1/4-18 tapered pipe thread] per MM § 1.320 and apply torque stripe per MM Figure 2-1. Position gascolator assembly drain valve thru hole in belly panel. Insert A455-1 plug in A454-1 support (see IPC Figure 28-21), then connect C741-1 line assembly to inlet nipple (marked "IN"), finger-tight. Install washer and nut on plug and special torque to 70 in.-lb, and torque stripe per MM Figure 2-1. Special torque C741-1 line assembly to 285 In.-lb, and torque stripe per MM Figure 2-1. If installed, connect primer line to bushing on gascolator outlet tee, special torque nut to 25 in.-lb, and torque stripe per MM Figure 2-1. Connect B283-3 hose assembly and special torque nut to 120 in.-lb, and torque stripe per MM Figure 2-1.

II. R44 II only: Refer to Figure 10.

- a. Install new D453-4 tee on aux tank outlet fitting, orient fitting in line with D321-1 pressure relief valve assembly within 5°, and special torque to 200 in.-lb. Install new D453-5 jet in tee inlet (outboard side). Connect C595-4 hose assembly elbow to tee inlet and straight fitting to pressure relief valve, special torque nuts to 120 in.-lb, and torque stripe per MM Figure 2-1. Remove temporary cap on C595-3 hose assembly and connect elbow fitting to D453-4 tee and special torque hose nut to 120 in.-lb; verify 0.5-inch minimum clearance from C595-4 hose assembly. Secure C595-3 hose assembly per View A-A; cinch ty-raps until snug without over-tightening, and trim tips flush with head.
- b. Remove inlet (inboard) fitting from engine fuel pump. Lubricate (1) MS29512-06 packing using A257-6 grease and assemble to D319-4 fitting. Install fitting in engine fuel pump inlet, special torque to 150 in.-lb, and torque stripe per MM Figure 2-1. Connect B283-3 hose assembly and special torque to 120 in.-lb.
- c. Examine D743 aux fuel pump and determine location of B426-2 fuel pressure switch.
 - i. If pressure switch is above motor, obtain and install KI-206-3 Revision D (or subsequent) Aux Fuel Pump Assembly Upgrade Kit.
 - ii. If pressure switch is opposite motor, then verify:
 - Elbows in pump, and
 - Fittings in gascolator inlet & outlet are stainless steel (non-magnetic) and/or blackened steel (magnetic).

Replace all blue, aluminum fittings with steel fittings using online instructions for KI-206-3.

Kit Instructions (continued)

63. Refer to Figure 8. Replace (3) MS35489-6 grommets in lower ribs. Observe orientation markings and install (2) D251-1 rollover vent valve assemblies through lower rib grommets and attach A729-48 (tank vent) tubes using (2) B277-4 clamps; if lower vent fittings are present (main and/or aux tank), verify A457-19 cap(s) are installed. Install (2) A729-79 tubes to valve assemblies and secure using (2) D277-6 clamps.

NOTE

Refer to MM § 12.210 for description of vent valve function.

64. Install A731-10 tube assembly and connect A729-79 tubes using (2) D277-6 clamps as shown. Install A729-63 tube between A729-48 tubes using (2) MS3367-4-9 ty-raps as shown. Secure A731-10 tube assembly to gearbox mast tube using (1) MS3367-6-0 ty-rap. Cinch ty-raps until snug without over-tightening, and trim tips flush with head.

65. Perform vent system check as follows:

NOTE

A hand-operated inflation pump, such as bicycle tire pump, may be used to create air flow for system check.

- a. Attach a temporary hose to open end of one tube of A731-10 tube assembly. Temporarily cap open end of adjacent tube.
 - b. With fuel caps installed, blow into temporary hose (do not use compressed air) and verify no air leaks.
 - c. Remove fuel cap from main tank. Blow into temporary hose and verify air flow from main tank neck opening. Secure cap on main tank.
 - d. Remove fuel cap from aux tank. Blow into temporary hose and verify air flow from aux tank neck opening. Secure cap on aux tank.
 - e. Remove temporary cap from tube end. Blow into temporary hose and verify air flow out open vent tube. If no air flow from vent, remove obstruction(s) in vent assembly and/or in fuel bladder(s) and repeat check.
 - f. Remove temporary hose.
66. Refer to Figure 8. Attach mast fairing to left side of upper rib. Route pitot line through grommet in rib. Create stand-off and secure pitot line to A731-10 tube assembly (left-side tube) using A729-63 tube and ty-raps as shown. Position MS21919WDG4 clamp around pitot line and secure clamp to C261-7 & -8 mid ribs using hardware shown. Connect pitot line to pitot tube. Perform pitot system and static system leak tests per MM § 13-10.
67. Reroute airframe wiring harness to main and aux tank fuel quantity senders and main tank low-fuel (warning light) switch assembly. Connect senders and switch to airframe harness and secure with ty-raps. Verify clearance to flight controls and rotating drive train.

Kit Instructions (continued)

68. Install D819-1 decal so it overlays the previous main tank quantity description printed on the D193 plate. Install D819-2 decal so it overlays the previous aux tank quantity description printed on the D193 plate. Insert MT106-3 tube in holder located on aux tank assembly aft bulkhead.
69. Perform fuel quantity indication check per MM § 12.412. Verify no fuel leaks.
70. Perform minimum fuel flow check per MM § 12.600.
71. R44 II only: Install airbox per MM § 6.430. Inspect induction hose per Service Bulletin SB-100; replace hose as required and install.
72. Install aft cabin foam insulation per MM § 15.400, as required. Install C474 trim & cover between aft seat backs, and left & right aft seat back assemblies.
73. Install aft belly panel, left, right, & aft cowlings, mast fairing, and tailcone cowling. Secure access doors.
74. If desired, paint (top coat) tanks to match helicopter (paint codes are on inside cover of factory-issued airframe logbook).
75. For helicopters that have not complied with R44 Service Bulletin SB-84, install D682-44 decals per SB-84.
76. Install C654-3 or C654-4 decal (as appropriate) near main tank filler cap. Install C654-5 or C654-6 decal (as appropriate) near aux tank filler cap.
77. Perform weight and balance procedure per MM § 1.230. Revise helicopter's Weight and Balance Record in R44 Pilot's Operating Handbook (POH) Section 6 to reflect this installation.
78. Run-up helicopter per Pilot's Operating Handbook.
79. Turn fuel valve OFF. Remove and clean gascolator bowl and filter screen. Verify no deterioration of gasket. If gascolator bowl is secured by threaded collar and ring, lightly lube threads and ring with A257-6 grease. Reassemble and turn fuel valve on. Safety wire after ensuring no leaks occur. Verify drain valve is secure and torque-striped.
80. Make appropriate maintenance record entries.

Kit Instructions (continued)

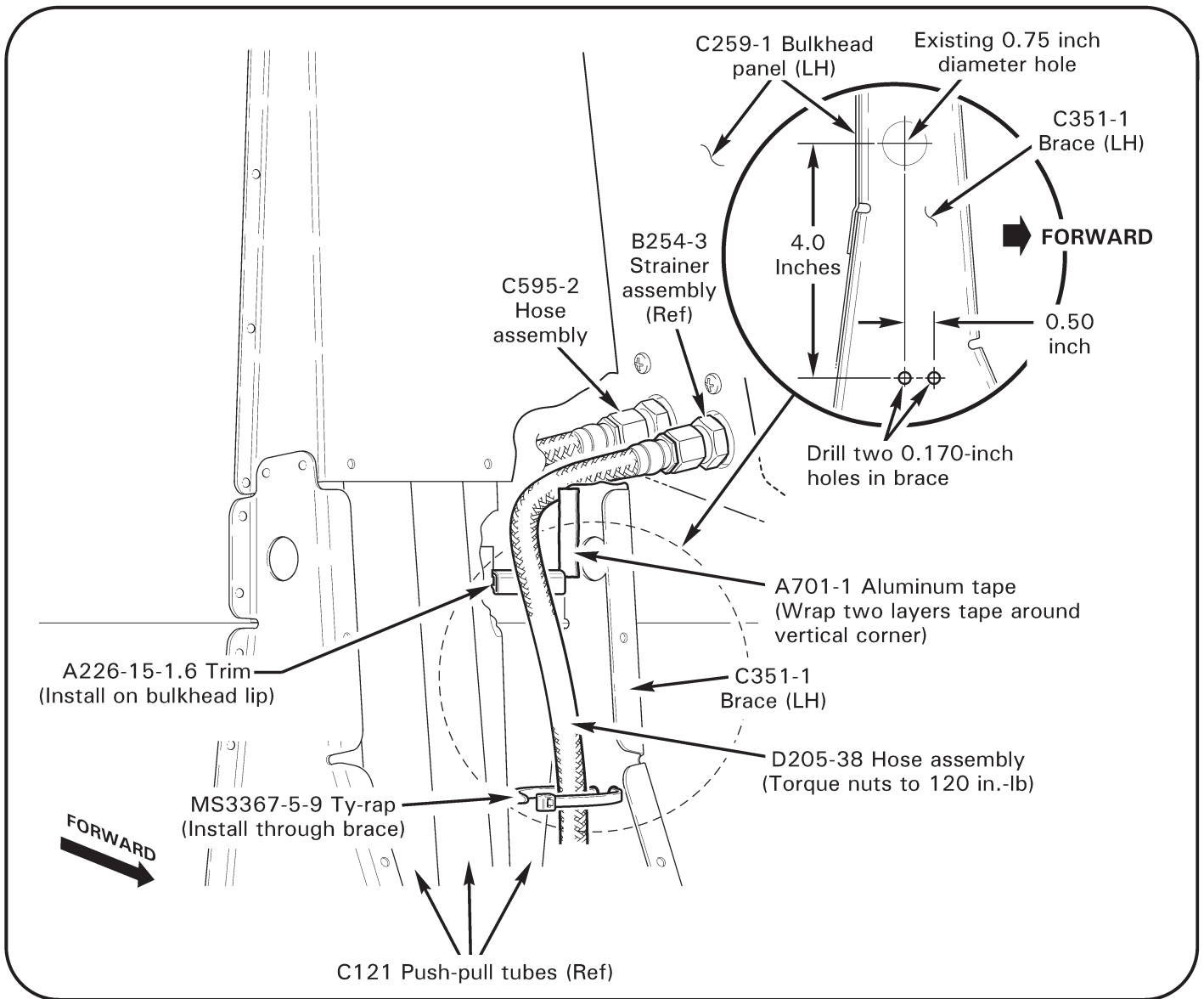

FIGURE 1

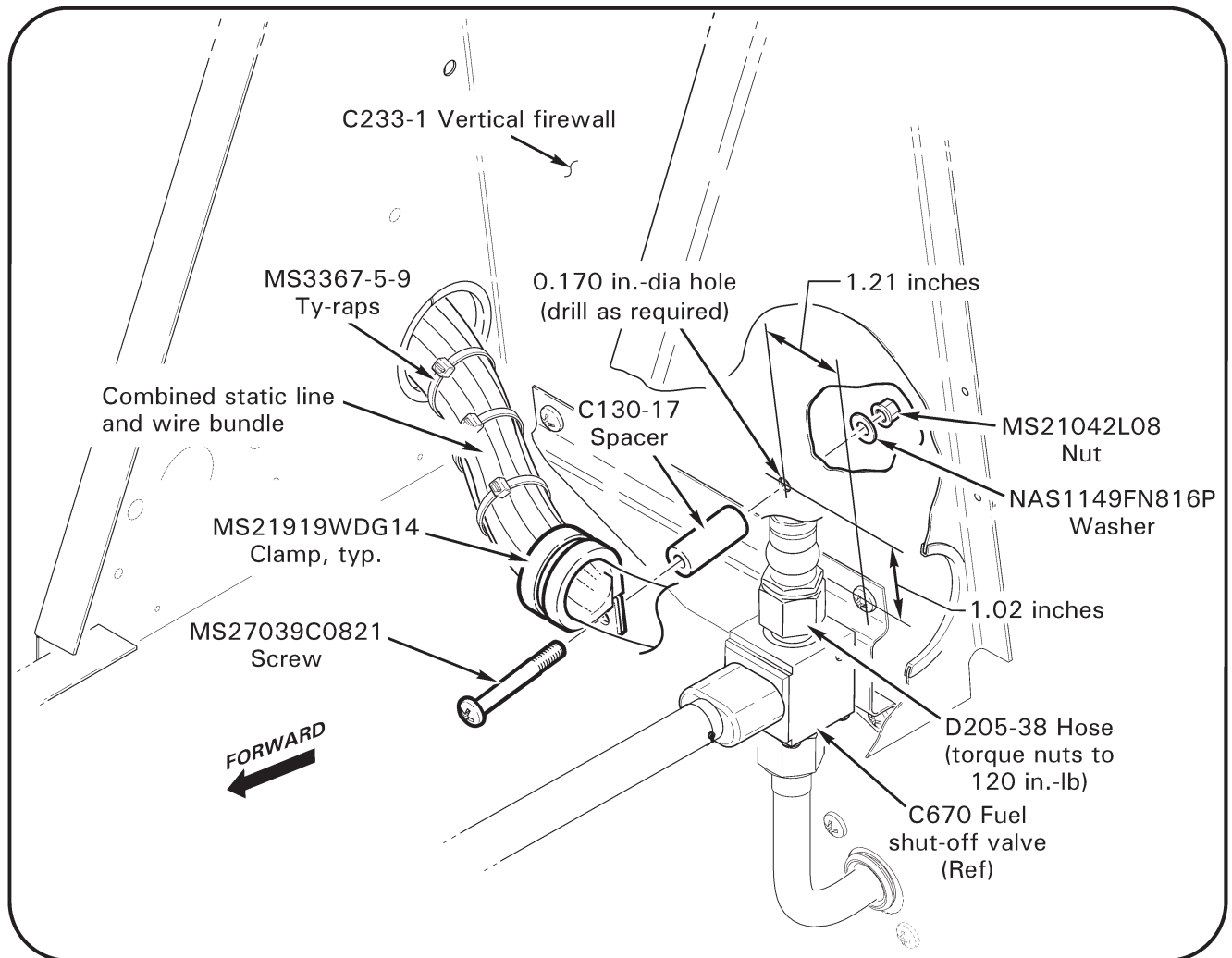
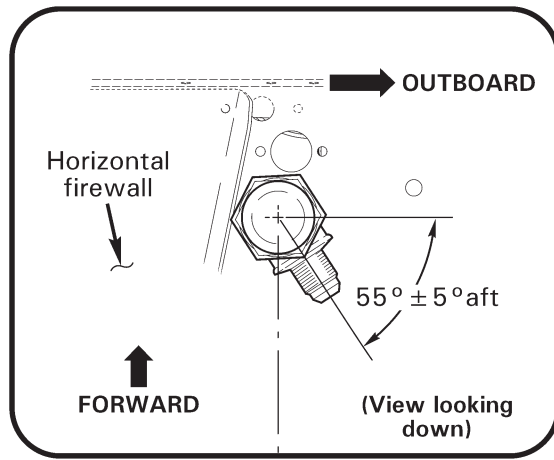

FIGURE 2



C259-2 Bulkhead panel (Ref)

D321-1 Pressure relief valve assembly (Ref)

A457-13 Connector (Ref)

Position pressure relief valve fitting by rotating loosened connector.

Horizontal firewall

Install new C141-5 washer under firewall.

Torque AN316-7R nut to 150 in.-lb.

B283-11 Hose assembly (Torque nut to 140 in.-lb)

FORWARD

FIGURE 3

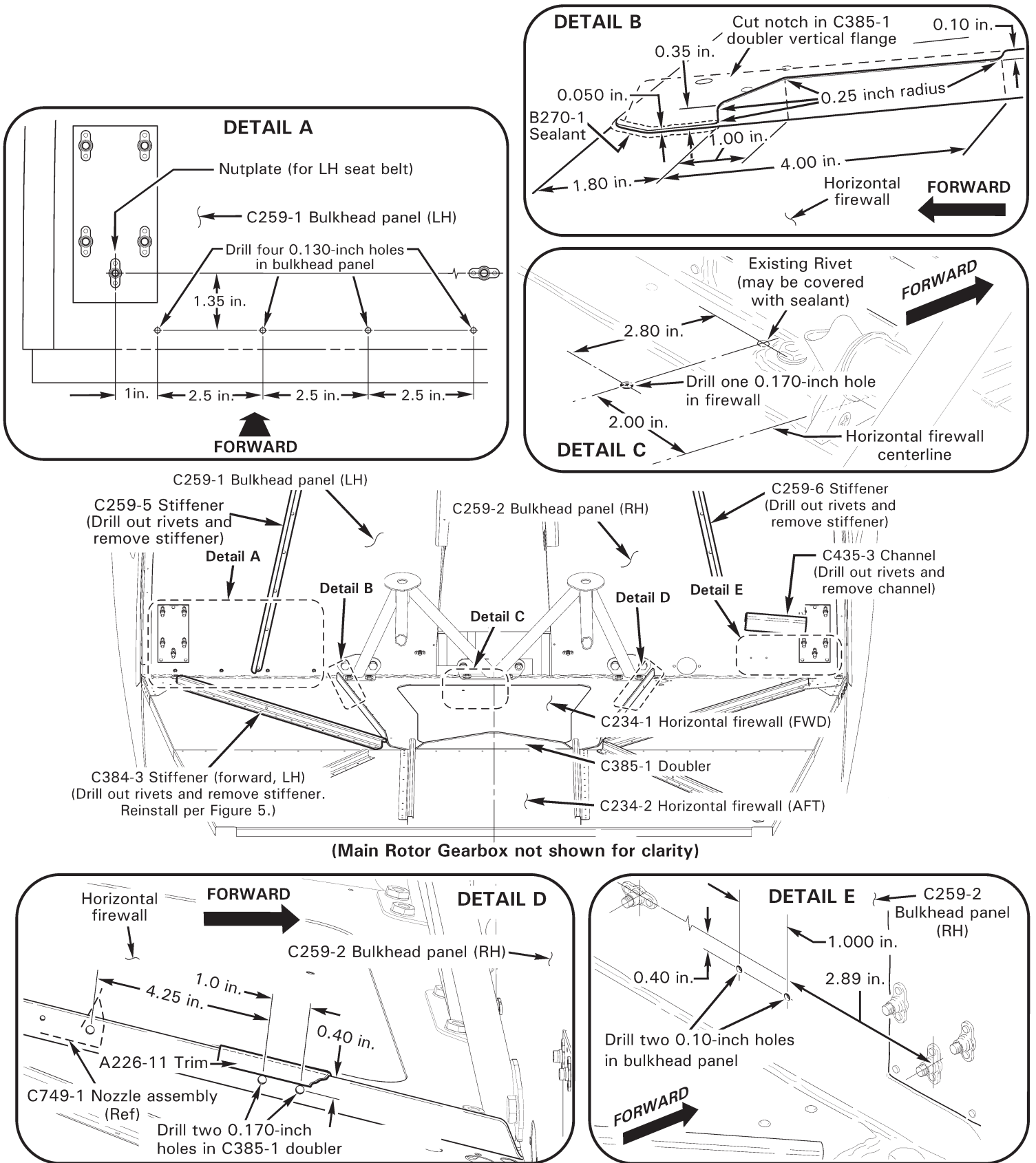

FIGURE 4

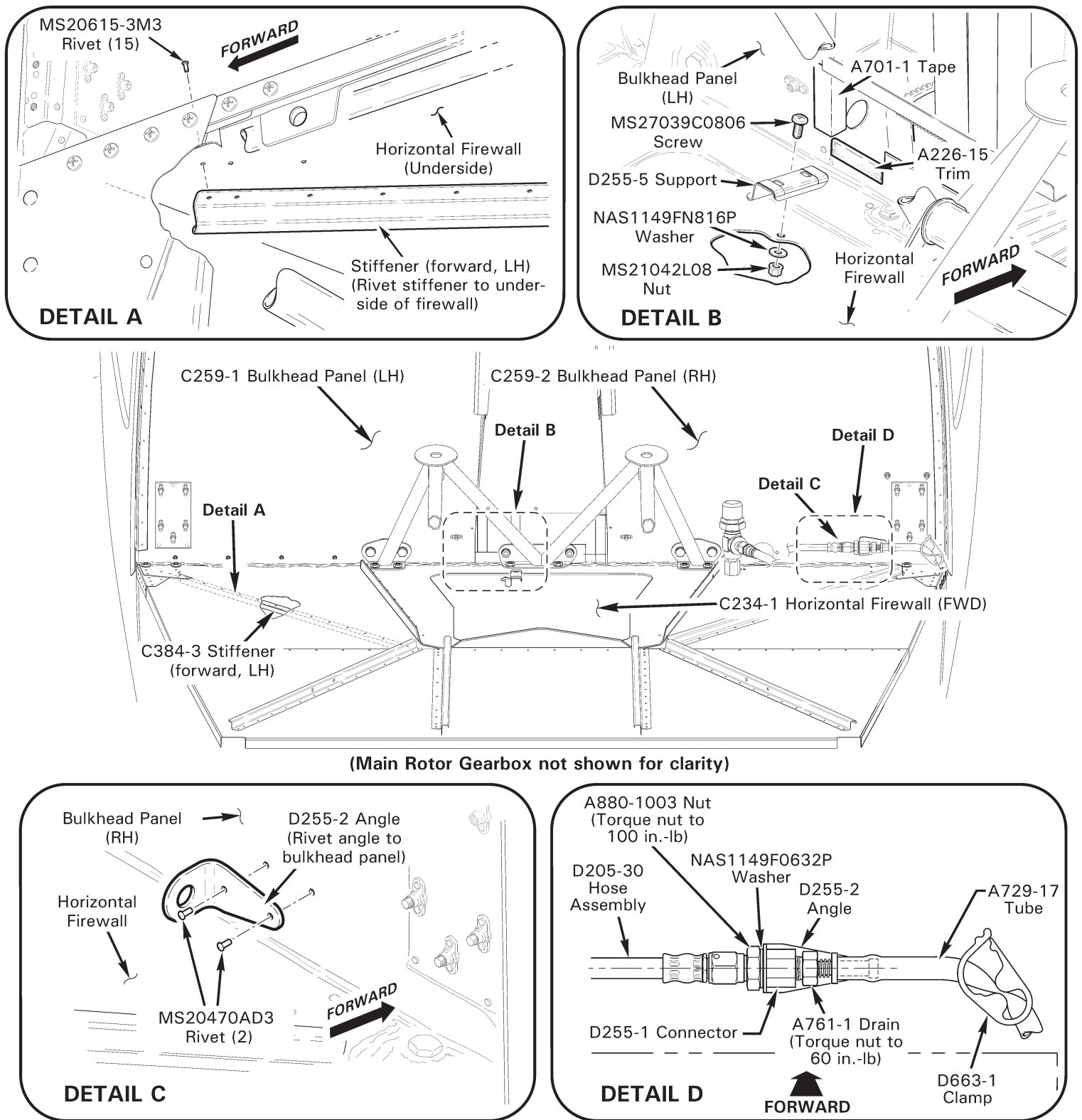
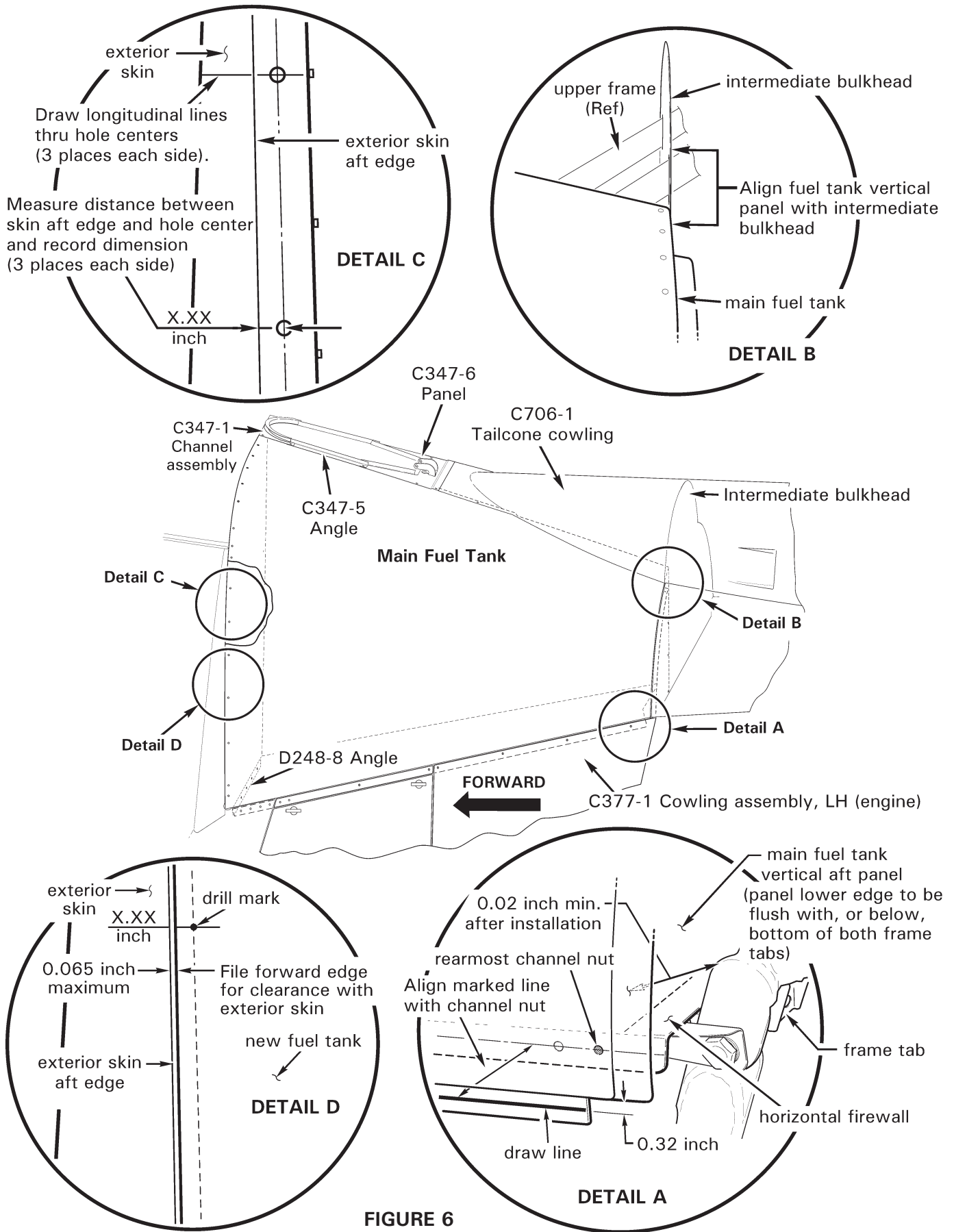
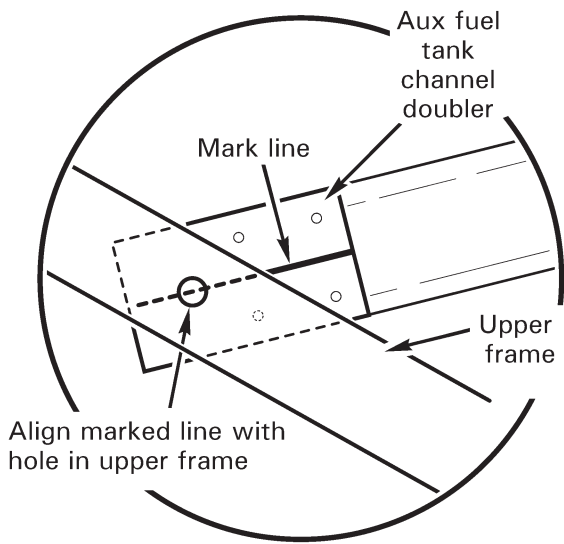
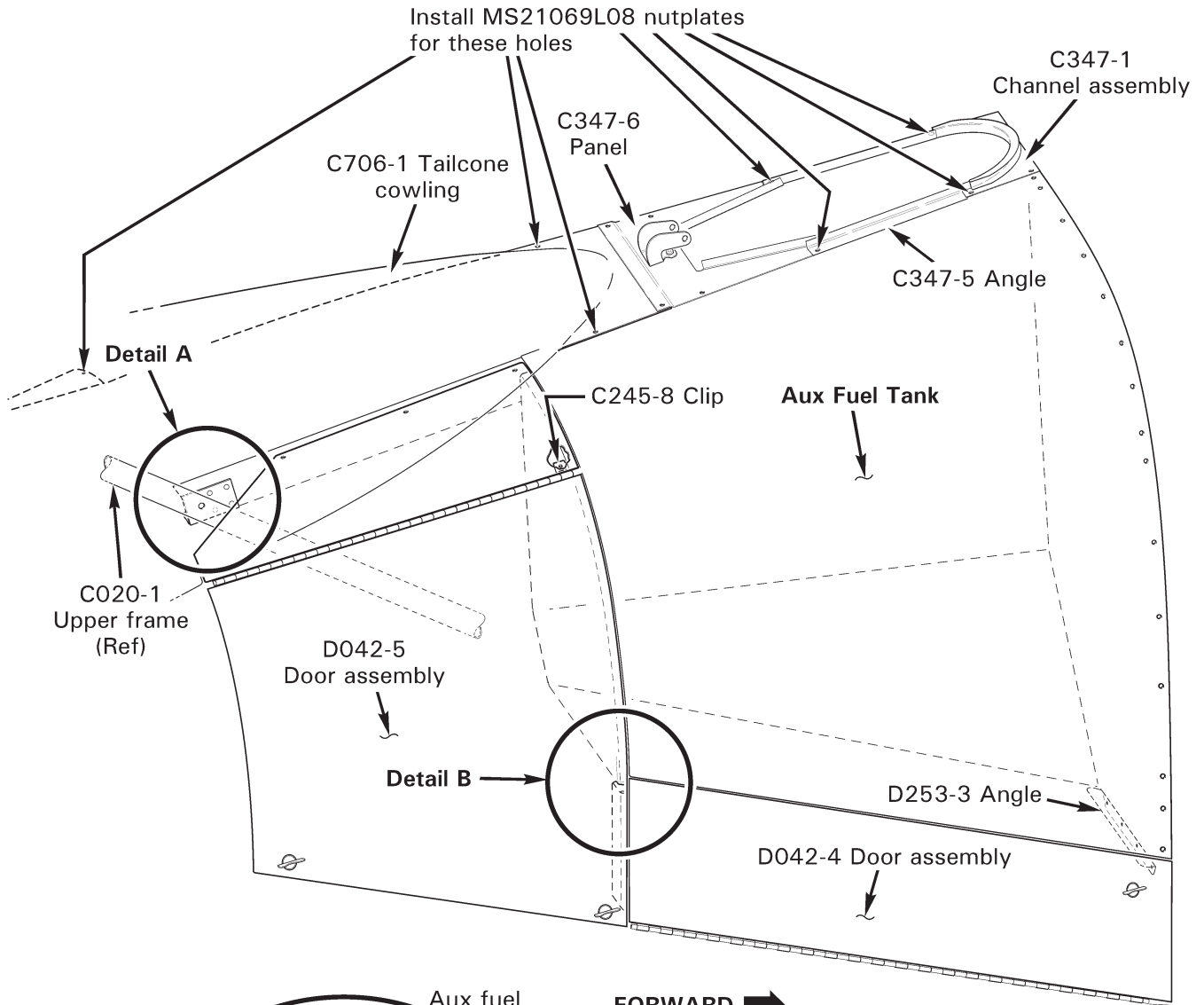

FIGURE 5





DETAIL A

FORWARD ➡

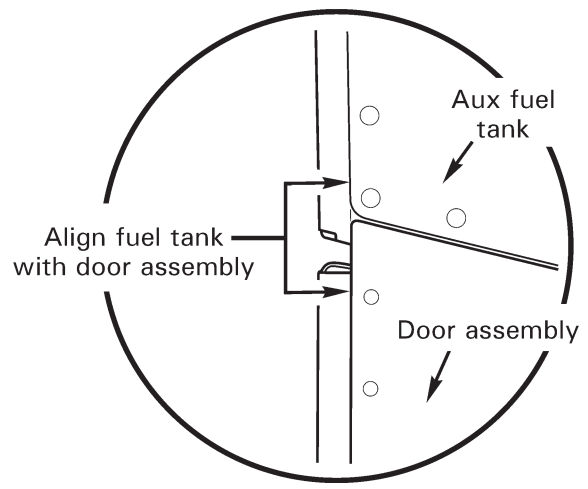

DETAIL B

FIGURE 7

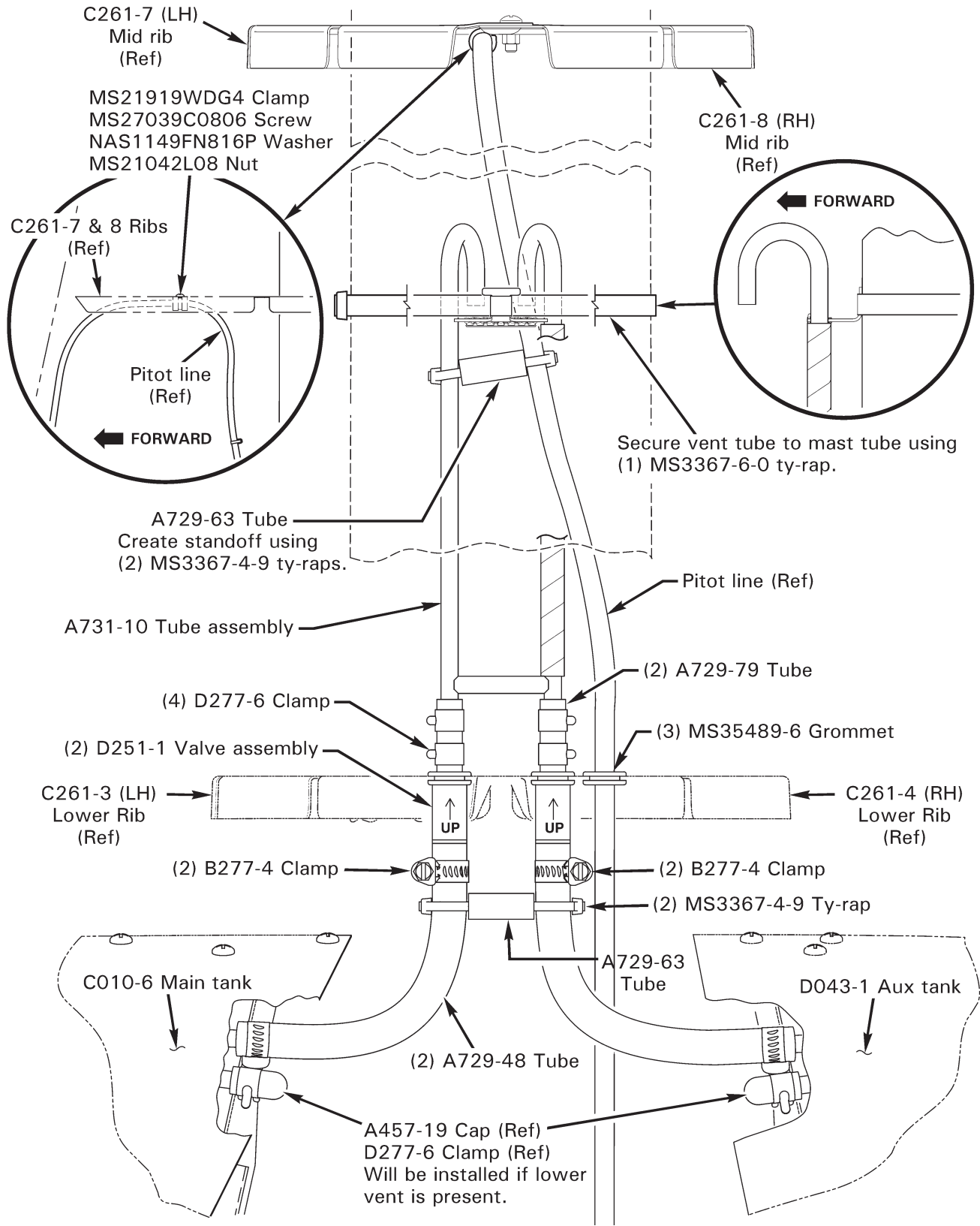

FIGURE 8
(view looking forward)

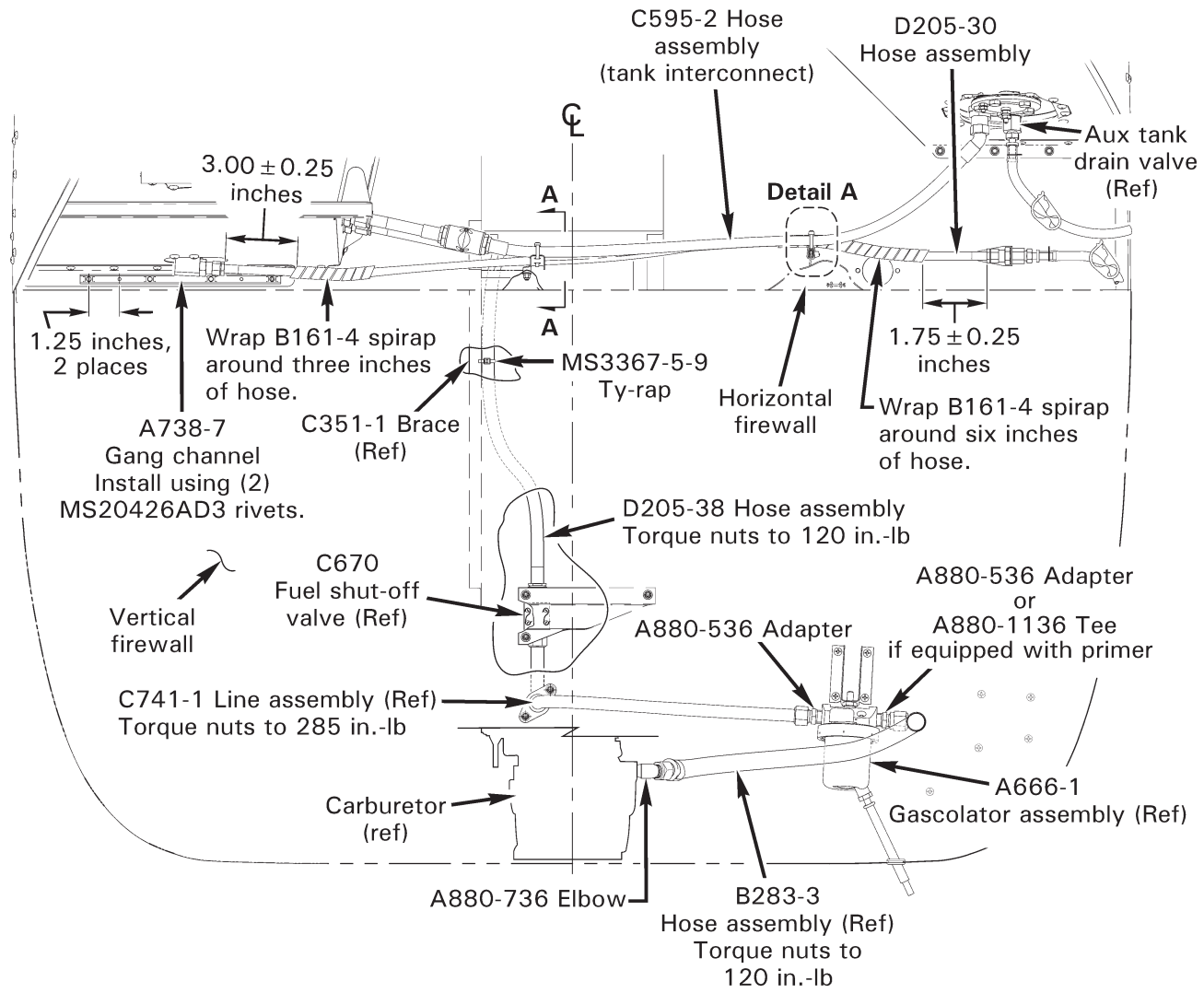
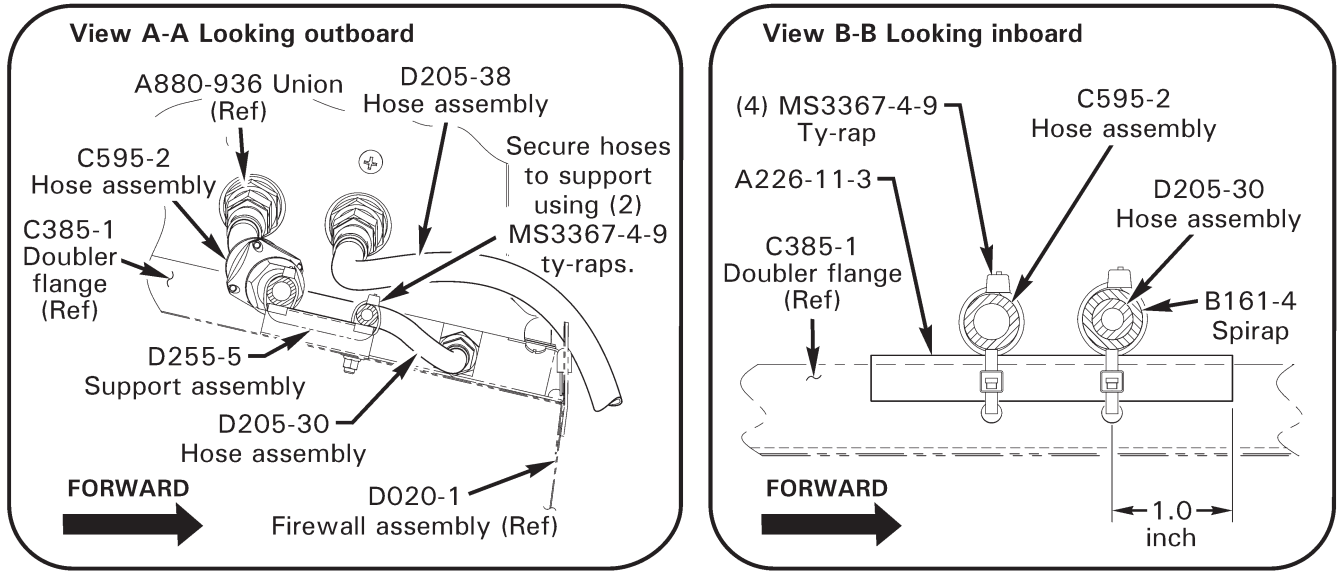

FIGURE 9 R44 Installation shown
 (view looking forward; R44 II installation same, except as shown in Figure 10)

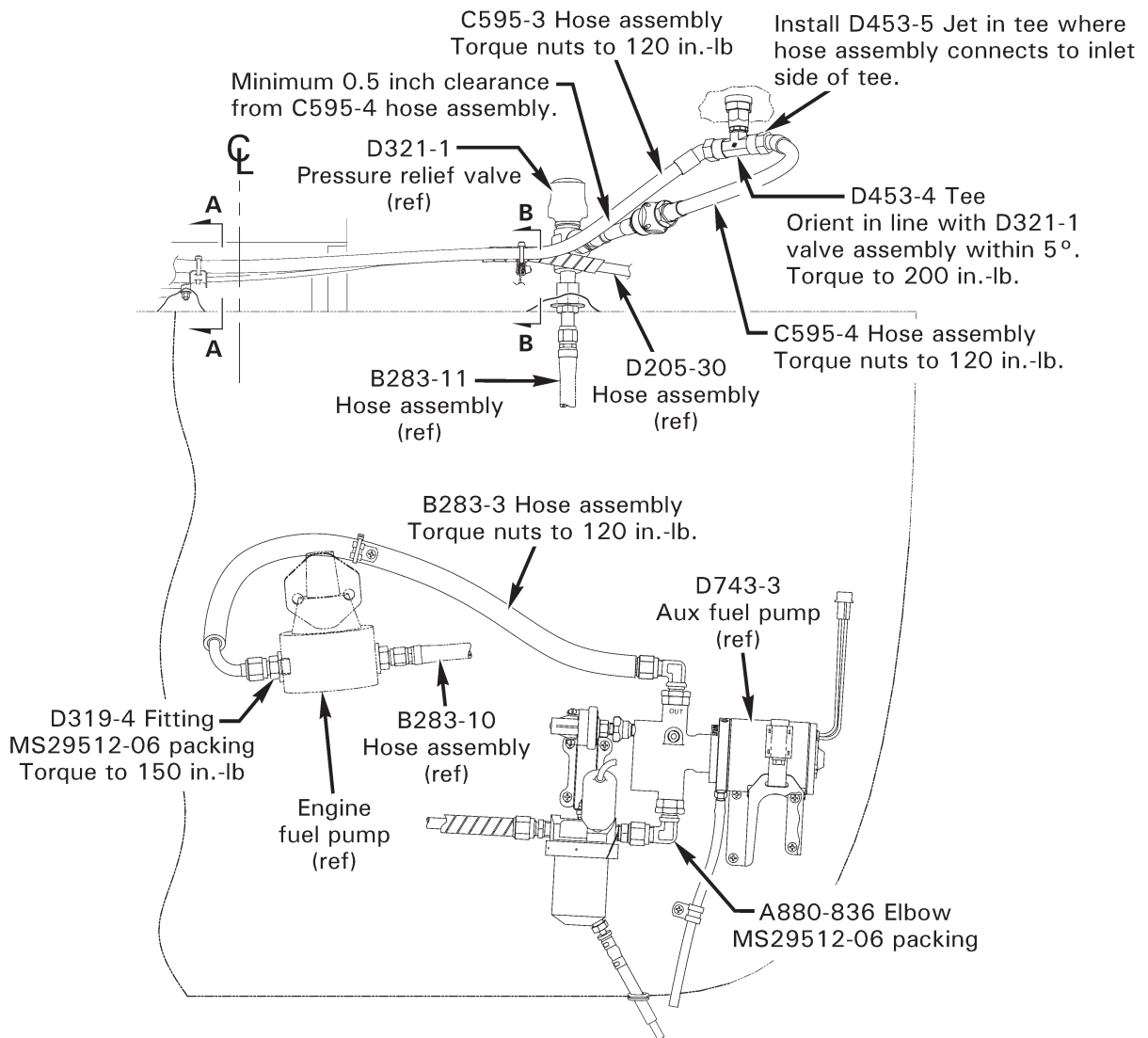
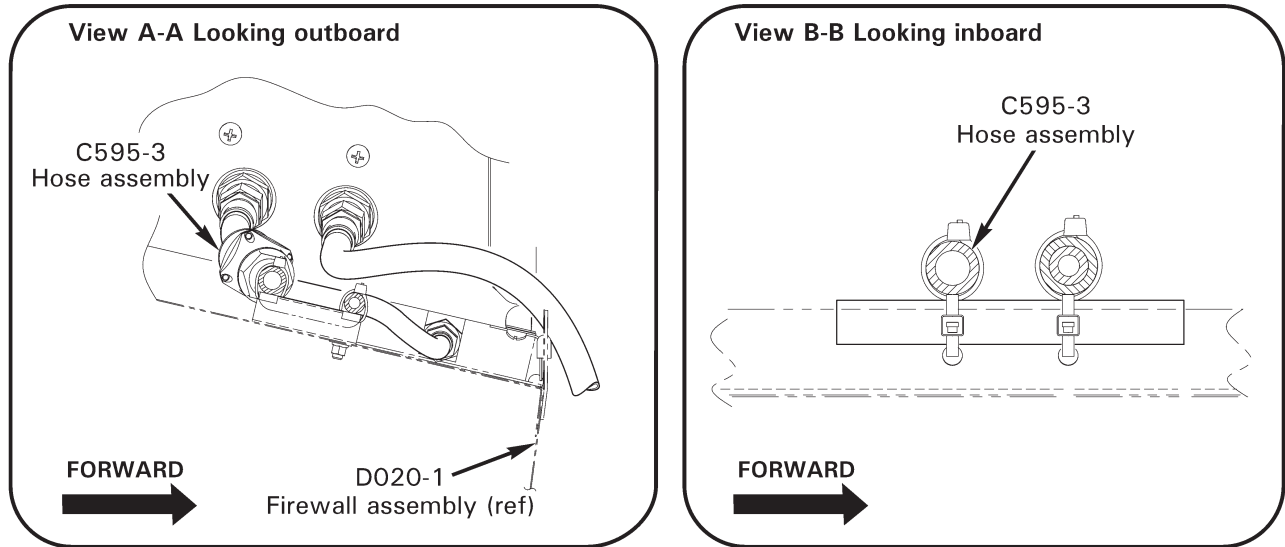

FIGURE 10 R44 II Installation
(view looking forward)