

R44 SERVICE BULLETIN SB-113

DATE: 16 March 2023

TO: R44-series Owners, Operators, and Maintenance Personnel

SUBJECT: Actuator Lower Bearing A185 Brackets

ROTORCRAFT AFFECTED:

R44 Helicopter S/Ns 2480 & prior,
R44 II Helicopter S/Ns 14089 & prior, and
R44 Cadet Helicopter S/Ns 30022 & prior.

Only helicopters with A185 brackets attached with rivets are affected. Brackets attached with (12) steel, hex-drive screws are not affected by this bulletin.

TIME OF COMPLIANCE: Within next 300 flight hours or by 31 March 2024, whichever occurs first.

BACKGROUND: Loose A185 brackets may allow the lower bearing housing to misalign resulting in belt-tension actuator damage, followed by possible loss of drive belt tension and subsequent loss of rotor drive. This bulletin requires verifying quantity & size of rivets attaching brackets to scroll, and replacing and/or retrofitting additional rivets if necessary.

COMPLIANCE PROCEDURE:

1. Refer to Figure on page 2. Visually inspect A185 brackets and verify three 5/32-inch [shank diameter] rivets attach bracket to scroll at each corner of C181 lower bearing (earlier brackets used 1/8-inch rivets and require upgrade). If there are less than (12) 5/32-inch rivets total, or if evidence of bracket looseness or fretting is found, repair scroll per R44 Service Letter SL-61 (latest revision).

NOTE

MS20470AD5 universal-head rivets have minimum 0.296-inch diameter head.
MS20426AD5 countersunk-head rivets have minimum 0.282-inch diameter head.

2. On lower A185 bracket, remove any previous vertical torque seal, then apply torque seal in a horizontal stripe across both outboard rivets to lower scroll to facilitate future inspections.

(OVER)

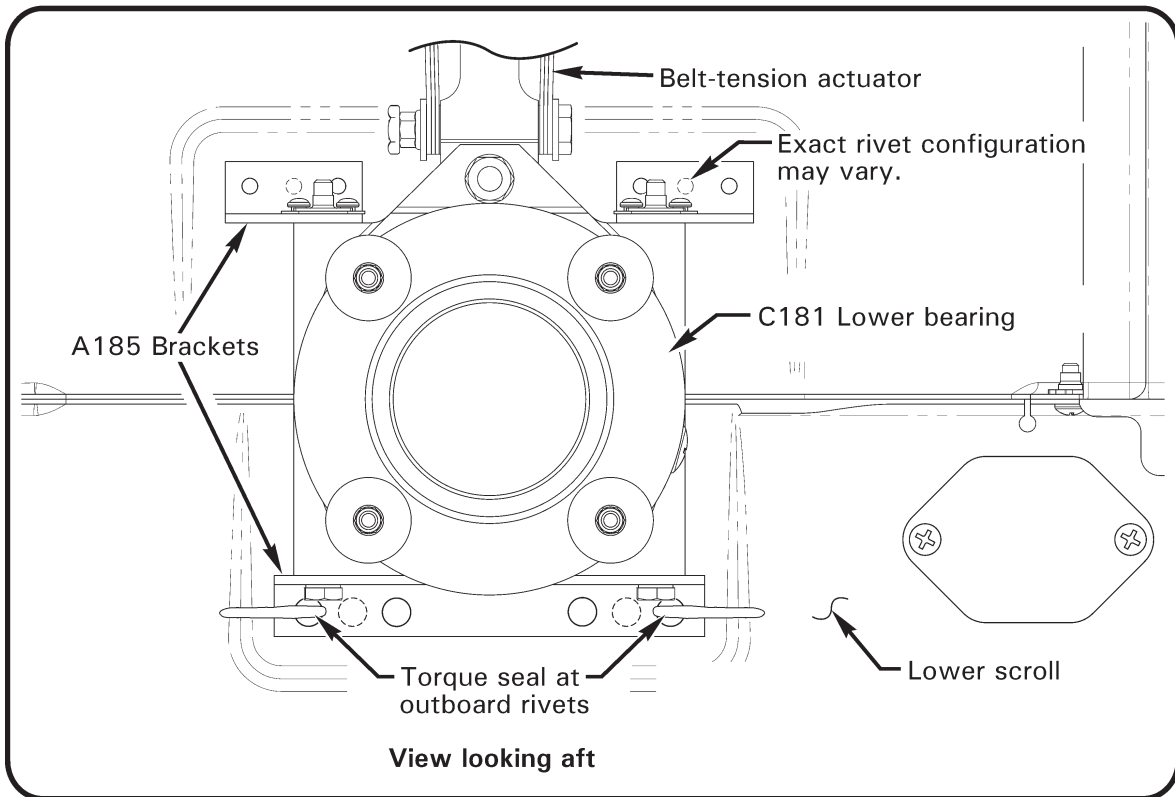

APPROXIMATE COST (inspection only):

Parts: None.

Labor: 0.5 labor-hour.