

MT850-1 RR300 Engine Stand Assembly Instructions

NOTE

Visit www.robinsonheli.com to verify kit instructions are current revision. Review instructions before assembly; contact RHC Technical Support with questions. Verify kit contents match list; contact RHC Customer Service if parts are missing or damaged.

ITEM	PART NUMBER	KIT CONTENTS	QTY
1	KI-250Instr.	Kit Instructions	1
2	B209-8	Plug	9
3	MT850-2	Frame Weldment	1
4	MT850-3	Base Weldment	2
5	MT850-5	Pivot Assembly	2
6	MT851-9	Gusset	2
7	RER-2x3-10-14	Plug	2
8	23055T43	Caster	2
9	23055T63	Caster	2
10	4050T31	Magnetic Pan	1
11	91102A755	Lockwasher	10
12	92865A105	Bolt	38
13	95462A510	Nut	28
14	NAS1149F0563P	Washer	56

Kit Instructions

1. Refer to Figure 1. Install MT851-9 gusset, one each side, to MT850-2 frame weldment using (4) 92865A105 bolts, (8) NAS1149F0563P washers, and (4) 95462A510 nuts with gusset and bolt heads on bottom of frame weldment.
2. Install MT850-2 frame weldment to MT850-3 base weldments using (8) 92865A105 bolts, (16) NAS1149F0563P washers, and (8) 95462A510 nuts.
3. Install two 23055T43 casters (fixed) and two 23055T63 casters (swivel) to MT850-3 base weldments using (16) 92865A105 bolts, (32) NAS1149F0563P washers, and (16) 95462A510 nuts, ensuring mating casters are installed on same ends of base weldments.
4. Torque (28) 95462A510 nuts to 175 in-lbs.
5. Install MT850-5 pivot assembly into saddle slot and engage pin into an aligned hole in pivot wheel. Install second pivot assembly on opposite side of stand.

Kit Instructions (continued)

- 6. Install (2) RER-2x3-10-14 plugs into each top tube of frame weldment. Install (9) B209-8 plugs.
- 7. Attach 4050T31 magnetic pan (location is optional). Remaining hardware ([10] 92865A105 bolts and [10] 91102A755 lockwashers used to secure RR300 engine to stand) may be stored in pan.

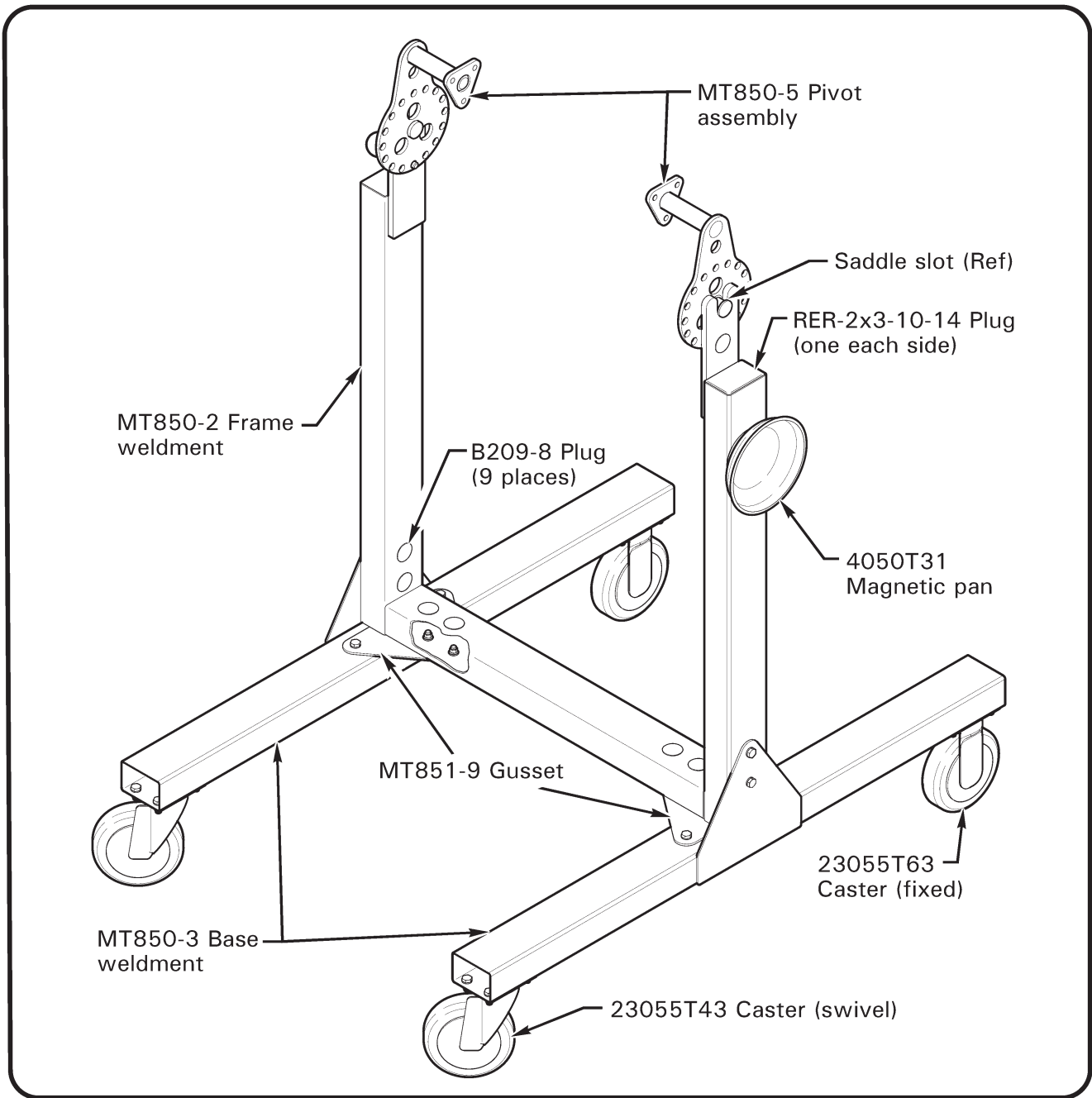

FIGURE 1