

CHAPTER 18

WEIGHT AND BALANCE

<u>Section</u>	<u>Title</u>	<u>Page</u>
18-10	Leveling	18.1
18-11	Leveling at Lower Right Side Frame Tube & Aft Landing Gear Cross Tube . .	18.1
18-12	Leveling at Main Rotor Hub	18.3
18-13	Leveling at Keel Panels	18.3
18-20	Weighing and CG Calculation	18.4
18-21	Preparing Helicopter for Weighing	18.4
18-22	Weighing Procedure and Calculations	18.5
18-30	Fixed Ballast	18.9

Intentionally Blank

CHAPTER 18

WEIGHT AND BALANCE

18-10 Leveling

NOTE

Perform leveling and weighing in a zero-wind environment.

NOTE

Verify spirit level is calibrated by placing level on a designated surface and noting bubble position. Rotate spirit level 180°; verify bubble is in the same position.

18-11 Leveling at Lower Right Side Frame Tube & Aft Landing Gear Cross Tube

NOTE

Use this leveling method for R22 Standard & R22 HP models only.

1. Place a bubble level on lower right steel tube frame horizontal member at location marked LEVEL HERE.
2. Level helicopter longitudinally by placing shims under landing gear skid tubes or jacks under outboard edge of aft cross tube.
3. Place bubble level on center of landing gear aft cross tube.
4. Level helicopter laterally by placing shims under landing gear skid tubes or jacks under outboard edge of aft cross tube.
5. Recheck level per steps 1 & 3 and adjust as required.

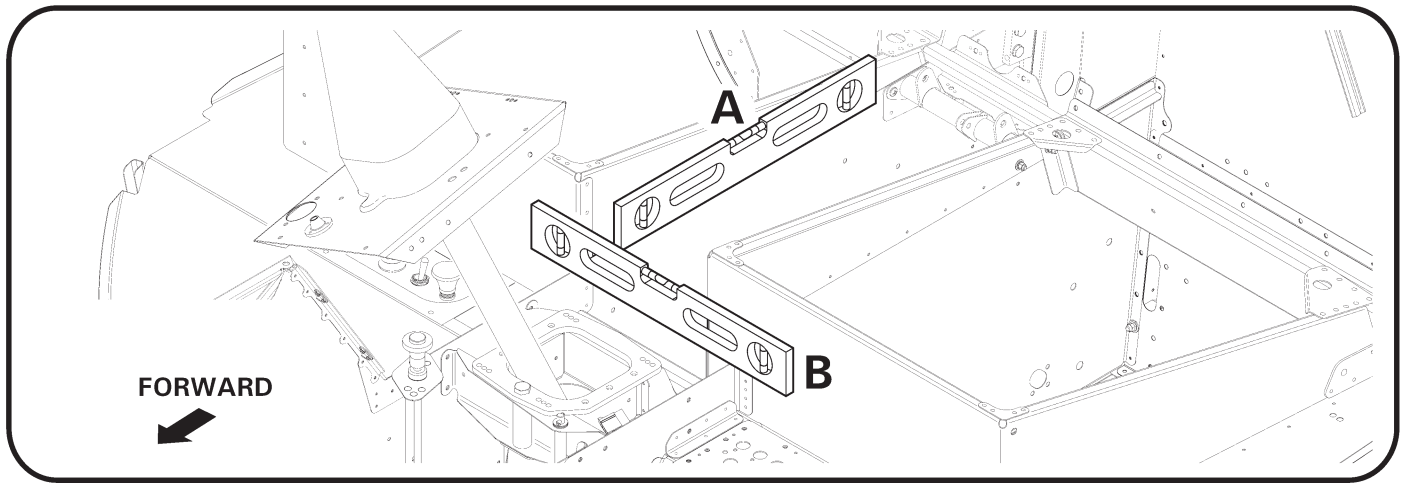

FIGURE 18-1 LEVELING AT KEEL PANELS

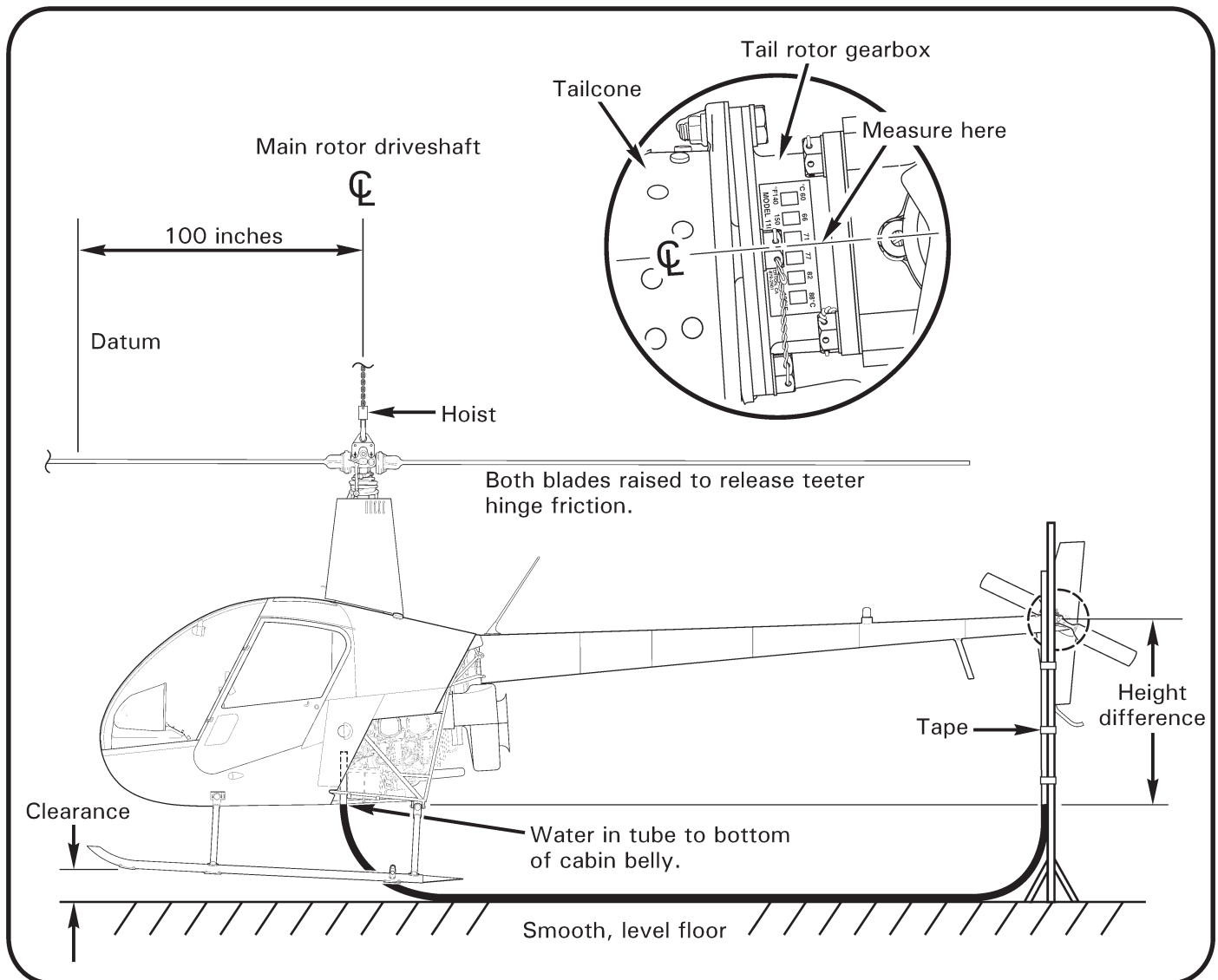

FIGURE 18-2 DETERMINING CG USING WATER LEVEL

18-12 Leveling at Main Rotor Hub**NOTE**

Use this leveling method for all R22 models.

1. Place a bubble level atop MR hub.

NOTE

Level must be parallel to teeter hinge bolt.

2. Rotate main rotor until teeter hinge bolt is aligned with longitudinal axis of helicopter.
3. Level helicopter longitudinally by placing shims under landing gear skid tubes or jacks under outboard edge of aft cross tube.
4. Rotate main rotor until teeter hinge bolt is aligned with lateral axis of helicopter.
5. Level helicopter laterally by placing shims under landing gear skid tubes or jacks under outboard edge of aft cross tube.

NOTE

Jacks may be used under aft cross tube 1 inch inboard from each elbow.

6. Recheck level per steps 2 & 4 and adjust as required.

18-13 Leveling at Keel Panels**NOTE**

Use this leveling method for all R22 models.

1. Remove horizontal panel between seat bottoms and remove cyclic box cover.
2. Place a bubble level on top edge of right keel panel per Figure 18-1 Detail A.
3. Level helicopter longitudinally by placing shims under landing gear skid tubes or jacks under outboard edge of aft cross tube.
4. Place a bubble level across two keel panels per Figure 18-1 Detail B.
5. Level helicopter laterally by placing shims under landing gear skid tubes or jacks under outboard edge of aft cross tube.
6. Recheck level per steps 2 & 4 and adjust as required.

18-20 Weighing and CG Calculation

Reweigh helicopter when helicopter empty weight and empty weight center of gravity have been modified and if the accuracy of additional calculations is suspect.

Maintain a continuous record of the helicopter's weight and balance using the Weight and Balance Record in R22 Pilot's Operating Handbook (POH) Section 6.

NOTE

Verify scales are calibrated. Operate scales according to scale manufacturer's instructions.

NOTE

Never weigh the helicopter in the wind. Weigh helicopter on a level, flat, hard surface in a zero-wind environment for accurate scale readings.

18-21 Preparing Helicopter for Weighing

1. Defuel helicopter per § 22-52.
2. Service engine oil per R22 Pilot's Operating Handbook (POH) Section 8. Fill main and tail gearboxes to center of sight gage using correct gearbox oil (refer to § 22-10 Part C).
3. Clean aircraft per POH Section 8. Verify helicopter is completely dry.
4. Remove items that are not installed equipment (tools, rags, charts, etc.) from baggage compartments and stowage areas.
5. Verify cowlings, removable panels, cabin doors, removable controls, and POH are installed.
6. Verify Equipment List/Weight and Balance Data sheet (RF 134) and modifications recorded in the Weight and Balance Record correspond with installed equipment and recorded equipment locations.

18-22 Weighing Procedure and Calculations

NOTE

- Arm is the distance in inches from datum.
- Datum is located 100 inches forward of main rotor centerline.
- CG (arm) is determined by dividing total moment by total weight.

1. Refer to § 18-20. Prepare helicopter for weighing per § 18-21.
2. Hoist helicopter per § 17-20 approximately one foot above the ground. Have one person hold tail of helicopter while hoisting to stabilize helicopter.
3. With main rotor blades oriented approximately fore and aft, raise both blades off of droop stops to allow hub to teeter freely. Raise tail slightly and allow to settle.
4. Refer to Figure 18-2. With aircraft hanging freely and steady, use a water level and measure difference in vertical height between tail rotor gearbox centerline and cabin belly at vertical firewall. Ensure no air bubbles in water level tube.

Record height difference: _____ inches

5. Determine longitudinal center of gravity:
 $114.47 - [0.315 \times (\text{height difference from step 4})] = \text{_____ inches}$
6. Place a 1000-lb capacity (minimum) scale under each skid. Locate center of scales approximately 10 inches forward of (ground handling wheel) skid supports.
7. Lower helicopter until it rests entirely on scales. Helicopter must be well balanced on scales before releasing tail. Be sure helicopter is level laterally by placing level on center of aft landing gear cross tube.

8. Determine empty weight:

Right scale reading:	_____	lb
Left scale reading:	+ _____	lb
Tare (leveling shims, hoist fixture, etc.):	- _____	lb
Empty weight:	= _____	lb

18-22 Weighing Procedure and Calculations (continued)

9. Determine CG with full fuel and minimum solo pilot:

a. Bladder tank(s):

i. **With aux tank:**

$$\frac{(CG \text{ from step 5}) \times (\text{Empty weight from step 8}) + 28495}{(\text{Empty weight from step 8}) + 303} = \text{_____ in.}$$

ii. **Without aux tank:**

$$\frac{(CG \text{ from step 5}) \times (\text{Empty weight from step 8}) + 22064}{(\text{Empty weight from step 8}) + 240} = \text{_____ in.}$$

b. All-aluminum tank(s):

i. **With aux tank:**

$$\frac{(CG \text{ from step 5}) \times (\text{Empty weight from step 8}) + 30180}{(\text{Empty weight from step 8}) + 319} = \text{_____ in.}$$

ii. **Without aux tank:**

$$\frac{(CG \text{ from step 5}) \times (\text{Empty weight from step 8}) + 23011}{(\text{Empty weight from step 8}) + 249} = \text{_____ in.}$$

10. If CG from step 9 is aft of aft limit (refer to R22 Pilot’s Operating Handbook [POH] Section 2 for model-specific data), determine required nose ballast:

$$\frac{[CG \text{ from step 5} - (\text{model's aft limit})] \times (\text{Empty weight from step 8}) - 2358}{64.5} = \text{_____ lb}$$

11. Adjust weight and balance to correct for drained unusable fuel and ballast:

Item	Weight (lb)	Longitudinal CG (arm, inches)	Moment (in.-lb)
Multiply empty weight from step 8 by CG from step 5	_____	x _____	= _____
Nose ballast:	_____	x 37.5	= _____
Unusable fuel (add):	10.2*, 6.0**, or 3.6***	x 100.0	= _____
	_____	_____	_____

* Bladder tanks

** All-aluminum tank(s) with aux tank

*** All-aluminum tank(s) without aux tank

18-22 Weighing Procedure and Calculations (continued)

CAUTION

CG with full fuel and minimum solo pilot weight must be at or forward of aft CG limit.

12. Determine lateral center of gravity:

$$\frac{(Right\ scale\ reading - Left\ scale\ reading)}{(Right\ scale\ reading + Left\ scale\ reading)} \times 37 = \underline{\hspace{2cm}}\text{ in.}$$

13. Determine lateral moment:

(Basic Empty Weight) x (lateral CG) = in.-lb

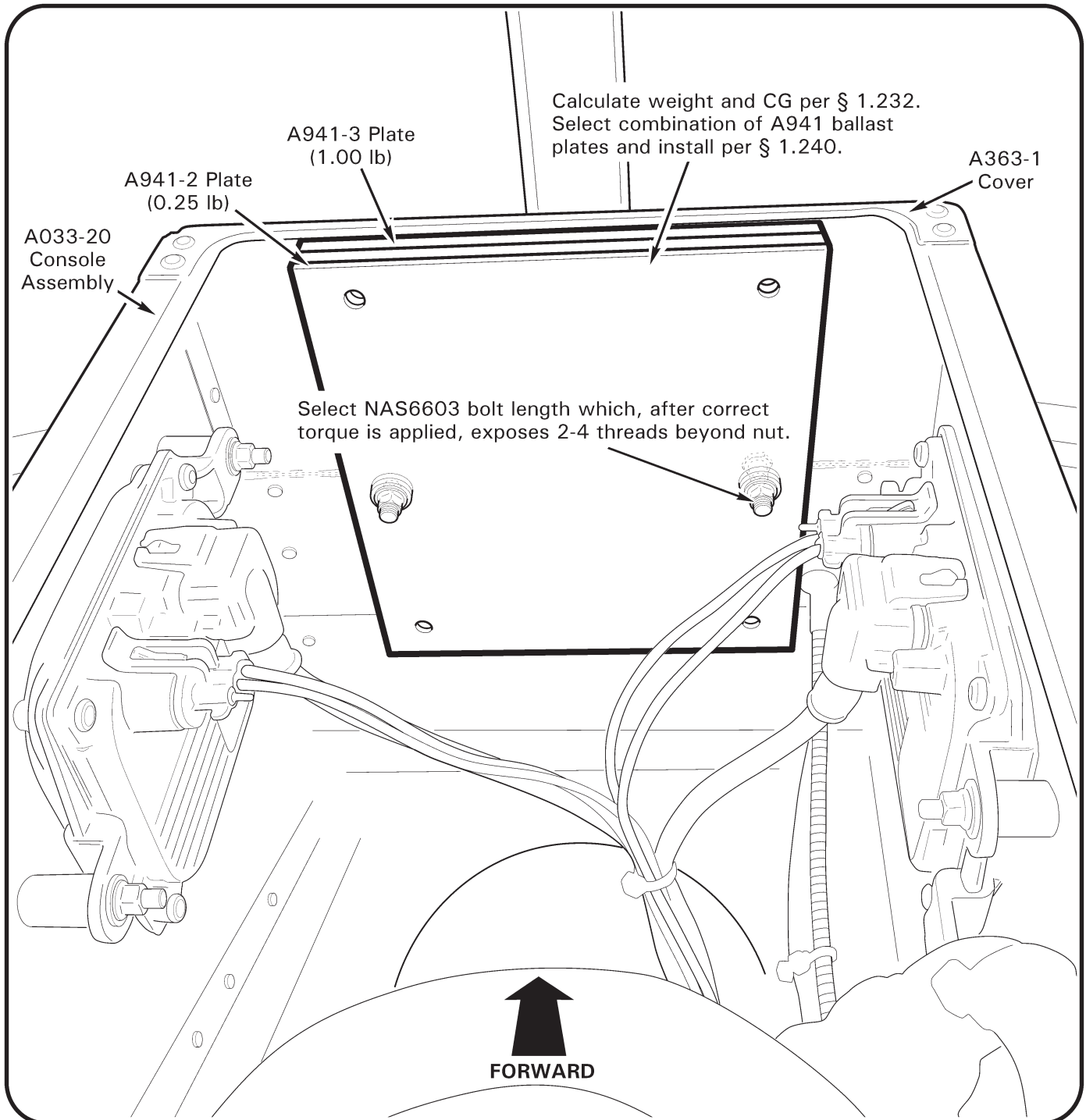

FIGURE 18-3 NOSE BALLAST
(View inside lower console assembly with upper console hinged aft)

18-30 Fixed Ballast

NOTE
Maximum allowable nose ballast is 10.0 lb.

CAUTION

Altering fixed ballast can appreciably affect helicopter center of gravity (CG). If fixed ballast information is unknown, reweigh helicopter per § 18-22.

1. Remove screws and hinge upper console assembly aft. Insert foam support or equivalent between console and cyclic to protect instrument faces.
2. Refer to Figure 8-3. Remove hardware securing A941-2 or -3 ballast plate(s), if installed, to A363-1 cover.
3. If A941 ballast attach holes are not previously drilled, use A941 ballast as template and mark hole locations. Drill 0.198 inch diameter (#8 drill size) hole at marked locations.
4. Remove or install ballast plates per calculations in § 18-22. Select NAS6603 bolt length to meet torque requirements per § 23-30. Install hardware, standard torque bolts per § 23-32, and torque stripe per Figure 2-1.
5. Remove foam, hinge upper console assembly forward, and install screws. Verify security.
6. Reweigh and/or calculate basic empty weight and CG per § 18-22.
7. Revise Weight and Balance Record in R22 Pilot's Operating Handbook (POH) Section 6 to reflect ballast removal or installation using the following data:

	Weight	Longitudinal Arm	Longitudinal Moment	Lateral Arm	Lateral Moment
Nose ballast	0–10.0 lb	37.5 in.	Variable	0.0 in.	0.0 in.-lb

Intentionally Blank