

CHAPTER 90
POLICE VERSION

<i>Figure</i>	<i>Title</i>	<i>Page</i>
90-1	Searchlight Installation	90.0
90-5	Searchlight Components	90.4
90-7	Searchlight Installation	90.6
90-11	PA/Siren Installation	90.10

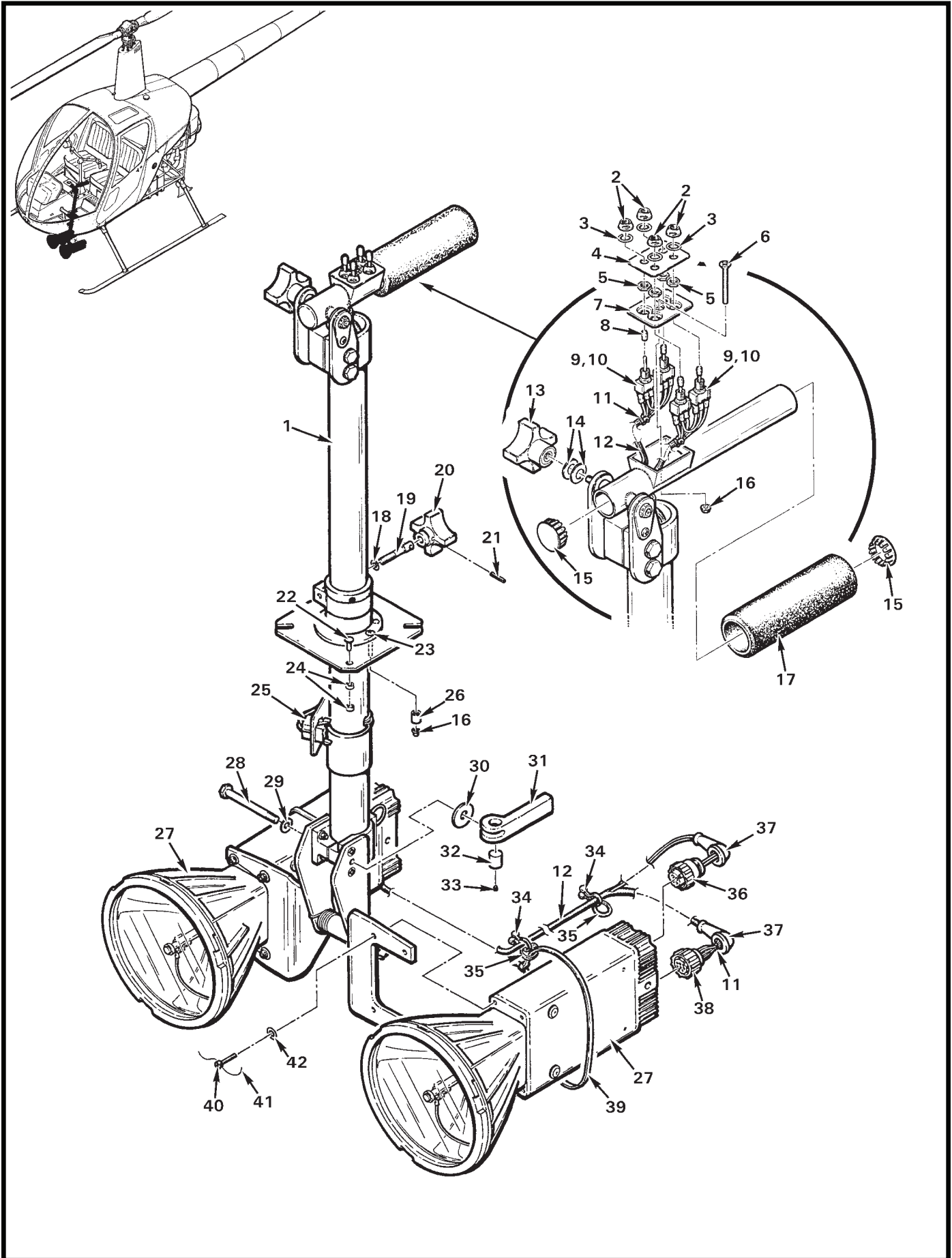

FIGURE AND INDEX NUMBER	PART NUMBER	DESCRIPTION	PARTS AVAIL	QTY PER ASSY
		SEARCHLIGHT INSTALLATION*		
90-1-1	B035-2	Searchlight Assembly (Incl items 4, 6, 7, 9, 11 thru 42, post assembly, and handle assembly)	O	1
2	B227-4	Dress Nut	X	2
3	B227-3	Lockwasher	X	2
4	B342-6	Plate (no longer available)	O	1
5	—	Nut	X	2
6	MS24694-S17	Screw	X	1
7	B342-5	Plate	O	1
8	7062	Cap (black)	O	2
9	B347-1	Wire Harness Assembly (Incl items 2, 3, 8, 10 thru 12)	O	2
10	7105-S-Y-Z-Q-E	Switch (includes item 5; B158-2 heat shrink around terminals)	X	2
11	B268-3	Tape	X	A/R
12	B266-4	Sleeving (expandable)	X	A/R
13	2820	Knob	X	1
14	B0500-022-S	Spring Washer	X	2
15	SS51334	Hole Plug	X	2
16	MS21042L08	Nut	X	2
17	A601-2	Grip (install using B270-8qt adhesive)	X	1
18	NAS620-10L	Washer	X	1
19	B210-10	Shaft	O	1
20	A499-2	Knob – Friction	X	1
21	MS16562-35	Spring Pin	X	1
22	MS20470AD4	Rivet	X	2
23	MS35206-248	Screw	O	1
24	A130-14	Spacer	X	4
25	B263-19	Housing	X	1
	B263-2	Socket	X	6
26	A130-34	Spacer	X	1
27	MBS-430**	Searchlight	O	2
28	NAS6603-31	Bolt	X	1
29	NAS1149F0332P	Washer	X	1
30	AN970-3	Washer	X	1
31	2ADP4-2	Handle (Ref, no longer available)		
32	7ADPC4	Barrel Nut	O	1
33	M77C640-002E	Set Screw	O	1

NOTES * Peak Beam Systems, Inc. Xenon lamp.
 ** Peak Beam Systems, Inc. part no.

Continues

FIGURE AND INDEX NUMBER	PART NUMBER	DESCRIPTION	PARTS AVAIL	QTY PER ASSY
SEARCHLIGHT INSTALLATION (Cont'd)				
90-1-34	TL-350	Tie (plastic)	X	4
35	MS3367-5-9	Ty-Rap	X	2
36	206060-1	Plug (use with B264-4 socket, [2] per plug)	X	2
37	MS25171-1S	Nipple	X	4
38	205838-1	Plug (use with 66504-9 socket, [6] per plug)	O	2
39	MS3367-6-0	Ty-Rap	X	2
40	NAS1352-08H10P	Screw	O	8
41	MS20995C20	0.020-inch dia Safety Wire	X	A/R
42	NAS1149FN816P	Washer	X	8

NOTES

Intentionally Blank

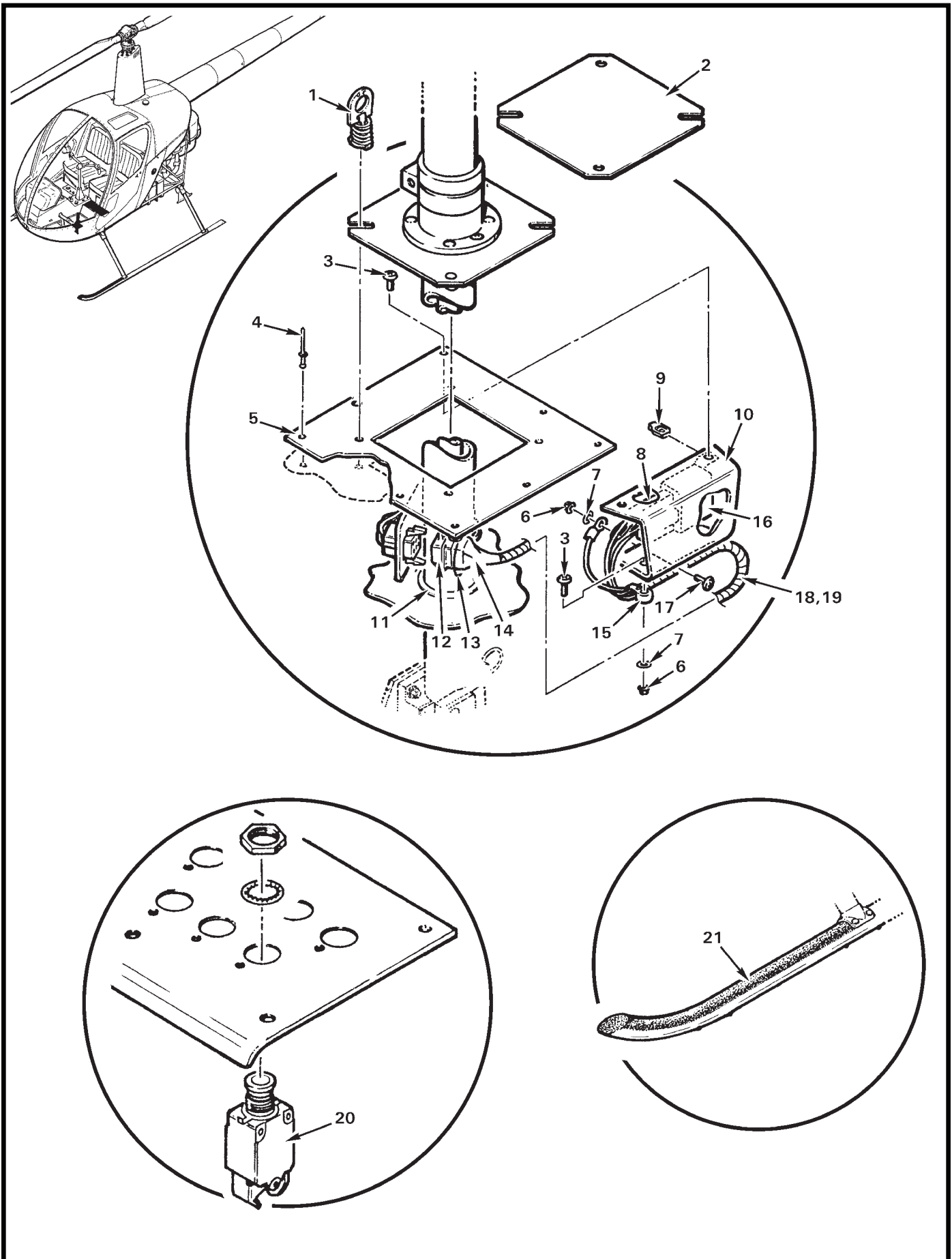

FIGURE AND INDEX NUMBER	PART NUMBER	DESCRIPTION	PARTS AVAIL	QTY PER ASSY
SEARCHLIGHT COMPONENTS*				
90-5-1	KM921-1	Fastener	X	2
2	A997-2	Cover (For use when searchlight is removed. Ref, no longer available.)		
3	MS27039C0807	Screw	X	2
4	NAS1919B04S02	Rivet	X	8
5	A995-1	Doubler (Ref, no longer available)		
6	MS21042L08	Nut	X	2
7	NAS1149FN816P	Washer	X	2
8	VCF7-1000	Connector	X	1
	B262-6	Receptacle (small)	X	2
	B262-7	Receptacle (large)	X	2
9	B162-2	Clipnut	X	2
10	A527-1	Guard	O	1
11	NAS557-22A	Grommet (install using B270-8qt adhesive)	X	1
12	B263-18	Housing (use with B263-1 pin, [6] per housing)	X	1
13	A215-116	O-Ring	X	1
14	B158-12	Heat Shrink	X	A/R
15	O8415	Ty-Rap	O	1
16	VF7-41F11	Relay	X	1
17	MS27039C0806	Screw	X	1
18	B309-1	Harness Assembly (Includes items 8, 12 thru 14, 19, wires, and B260-12 terminal.)	O	1
19	B161-4	Spirap	X	A/R
20	B297-20	Circuit Breaker (20-amp)	X	1
21	X-1567	Wing-Walk Compound (black, one-quart can)	X	A/R

NOTES * For additional components see Figure 90-1.

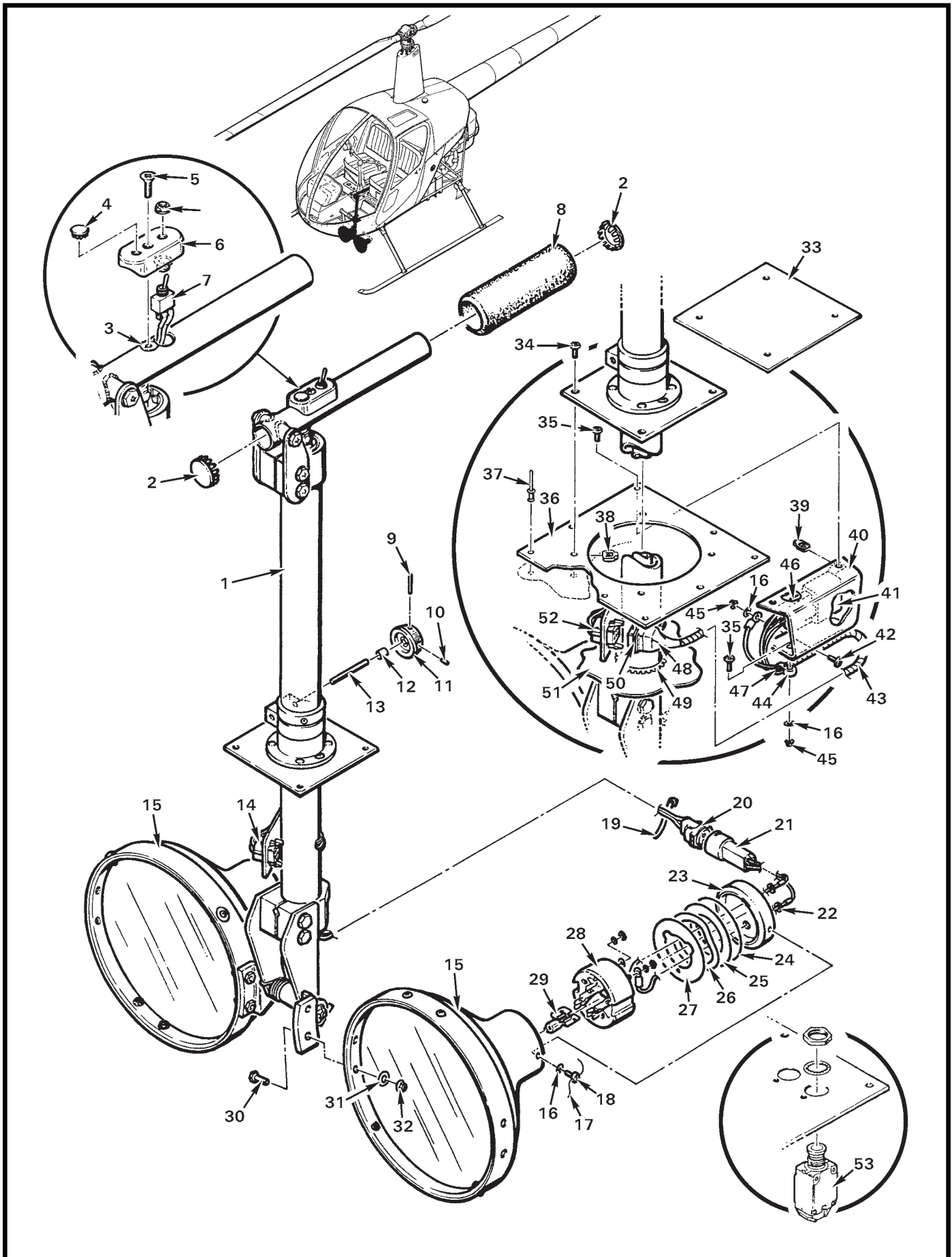

FIGURE AND INDEX NUMBER	PART NUMBER	DESCRIPTION	PARTS AVAIL	QTY PER ASSY
		SEARCHLIGHT INSTALLATION		
90-7-1	B031-1	Searchlight Assembly (Ref; includes items 2 thru 15, 19, 20, 30 thru 32, post assembly, and handle assembly. No longer available.)		
2	SS51334	Hole Plug	X	2
3	NAS1329H08K75L	Rivnut	X	1
4	B209-6	Hole Plug	X	1
5	MS24693-S51	Screw	X	1
6	A216-2	Housing (no longer available)	O	1
7	B300-1	Switch (includes washer and nuts)	X	1
8	A601-2	Grip	X	1
	B270-8qt	Adhesive (use to install A601-2 grip, 1-quart can)	X	A/R
9	MS16562-27	Roll Pin	X	1
10	—	Set Screw	O	1
11	A483-1	Knob (Incl item 10)	X	1
12	A130-25	Spacer	X	1
13	B210-6	Shaft (Ref, no longer available)		
14	B263-19	Housing	X	1
	B263-2	Socket	X	6
15	B211-1	Light Assembly (LH and RH; includes items 16 thru 18, and 21 thru 29. No longer available.)	O	2
16	NAS1149FN816P	Washer	X	4
17	MS20995C32	0.032-inch dia Safety Wire	X	A/R
18	AN503-8-6	Screw	X	2
19	MS3367-4-9	Ty-rap	X	A/R
20	B172-4*	Wire Harness Assembly (left lamp, no longer available)	O	1
	B172-6*	Wire Harness Assembly (right lamp, no longer available)	O	1
21	B172-5	Wire Harness Assembly (Includes B264-12 receptacle, B264-3 pin [2], and B260-2 terminal [2]. No longer available.)	O	1
22	MS35489-4	Grommet (or AN931-3-5)	X	2
23	B212-1	End Cap	O	1
24	A215-137	O-Ring	O	1
25	A141-28	Washer	X	1
26	W2132-023	Spring Washer	O	1
27	B212-3	Washer	O	1
28	—	Insulator (Ref)	O	1
29	H2100	Lamp (12-volt, 100-watt)	X	1

NOTES * Includes B264-13 plug, B264-4 socket (2), and B263-2 terminal (2).

Continues

FIGURE AND INDEX NUMBER	PART NUMBER	DESCRIPTION	PARTS AVAIL	QTY PER ASSY
SEARCHLIGHT INSTALLATION (Cont'd)				
90-7-30	NAS6603-5	Bolt	X	2
31	NAS1149FO332P	Washer	X	2
32	MS21042L3	Nut	X	2
33	A997-2	Cover (For use when searchlight is removed. Ref; no longer available.)		
34	MS27039C0808	Screw	X	4
35	MS27039C0807	Screw	X	3
36	B349-1	Doubler (no longer available)	0	1
37	NAS1919B04S02	Rivet	X	8
38	B162-3	Clipnut	X	4
39	B162-2	Clipnut	X	2
40	A527-1	Guard	X	1
41	VF7-41F11	Relay	X	1
42	MS27039C0806	Screw	X	1
43	B161-4	Spirap	X	A/R
44	O8415	Ty-Rap	X	1
45	MS21042L08	Nut	X	2
46	VCF7-1000	Connector	X	1
	B262-6	Receptacle (small)	X	2
	B262-7	Receptacle (large)	X	2
47	B309-1	Harness Assembly (Incl items 43, 44, 46, 48, and 50)	X	1
48	B158-12	Heat Shrink	X	A/R
49	NAS557-22A	Grommet	X	A/R
50	B263-18	Housing	X	1
	B263-1	Pin	X	6
	A215-116	O-Ring	X	1
51	A272-1	Chin (Ref)		
52	B263-19	Housing	X	1
	B263-2	Socket	X	6
53	B297-20	Circuit Breaker (20-amp)	X	1
54	X-1567	Wing-Walk Compound (Black, one-quart can; not shown. See Figure 90-5.)	X	A/R

NOTES

Intentionally Blank

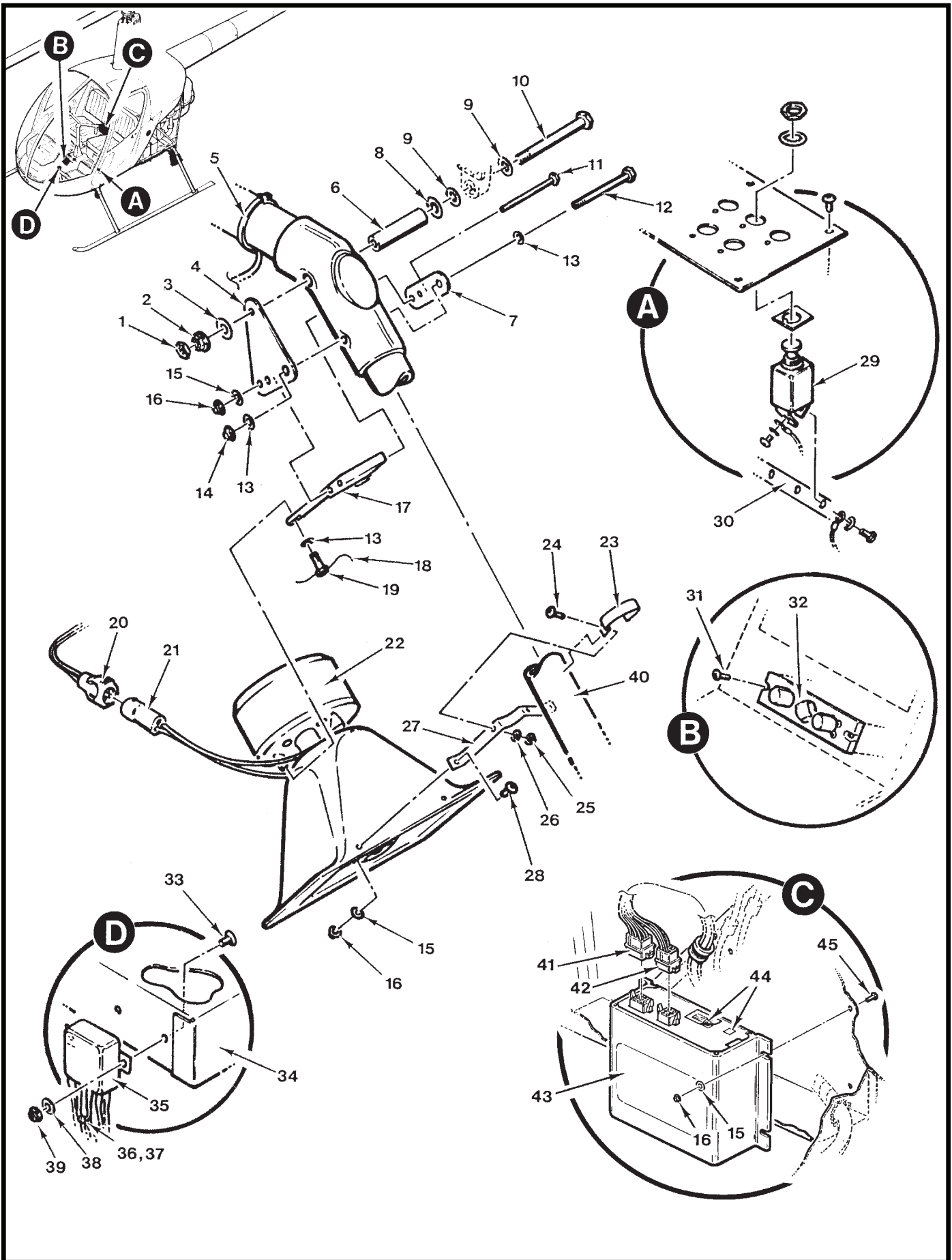

FIGURE AND INDEX NUMBER	PART NUMBER	DESCRIPTION	PARTS AVAIL	QTY PER ASSY
PA/SIREN INSTALLATION				
90-11-1	B330-19	Palnut	X	1
2	MS21042L6	Nut	X	1
3	NAS1149F0632P	Washer	X	1
4	A663-1	Plate	X	1
5	MS3367-4-9	Ty-Rap	X	A/R
6	A278-1	Spacer	X	1
7	A663-2	Plate	X	1
8	A214-1	Washer	X	1
9	A141-23	Washer	X	2
10	NAS6606-42	Bolt	X	1
11	NAS6603-36	Bolt	X	2
12	NAS6604-34	Bolt	X	1
13	NAS1149F0432P	Washer	X	5
14	MS21042L4	Nut	X	1
15	NAS1149F0363P	Washer	X	8
16	MS21042L3	Nut	X	8
17	A644-2	Support	O	1
18	MS20995C32	0.032-inch dia Safety Wire	X	A/R
19	MS20074-04-03	Bolt	X	3
20	B264-12	Receptacle	X	1
	B264-3	Pin (for use with item 20)	X	2
21	B264-13	Plug	X	1
	B264-4	Socket (for use with item 21)	X	2
22	SA340TS	Siren Speaker	X	1
23	A662-1 *	Bracket (use with 4.34-inch wide speaker cone)	O	1
	A662-3	Bracket (use with 5.20-inch wide speaker cone)	O	1
24	MS27039C0806	Screw	X	2
25	MS21042L08	Nut	X	2
26	NAS1149FN832P	Washer	X	2
27	A662-2 *	Bracket (use with 4.34-inch wide speaker cone)	O	1
	A662-4	Bracket (use with 5.20-inch wide speaker cone)	O	1
28	MS27039C1-06	Screw	X	2
29	B297-10	Circuit Breaker (10 amp)	X	1
30	A448-1	Bus Bar (Ref)		
31	MS35206-228	Screw	X	2

NOTES * Earlier R22s.

Continues

FIGURE AND INDEX NUMBER	PART NUMBER	DESCRIPTION	PARTS AVAIL	QTY PER ASSY
PA/SIREN INSTALLATION (Cont'd)				
90-11-32	A687-3	PA/Siren Control (use only with item 43)	X	1
33	MS35206-215	Screw	X	2
34	—	Radio Tray (Ref)		
35	FW-1111-D00	Relay (if equipped)	X	1
36	D275-102	Diode	X	1
37	B158-3	Heat Shrink	X	A/R
38	NAS1149FN416P	Washer	X	2
39	MS21042L04	Nut	X	2
40	A239-1	Strut (Ref)		
41	B263-20	Housing	X	1
	B263-1	Pin	X	6
42	B263-18	Housing	X	1
	B263-1	Pin	X	4
43	BETA112R	Amplifier (use only with item 32)	X	1
44	A701-1	Foil Tape	X	A/R
45	AN525-10R9	Screw	X	4

NOTES