

R66-series Lithium-Ion Battery Installation Diode Upgrade Kit Instructions
 (To comply with R66 Service Bulletin SB-32)

NOTE

Visit www.robinsonheli.com to verify kit instructions are current revision. Review instructions before installation; contact RHC Technical Support with questions. Verify kit contents match list; contact RHC Customer Service if parts are missing or damaged.

ITEM	PART NUMBER	KIT CONTENTS	QTY
1	KI-266Instr.	Kit Instructions	1
2	B158-6-SB-32	Heat Shrink – 3/8-inch diameter, 1.50 inches long (marked “SB-32”)	1
3	B261-2	Splice	1
4	KI-266-2882	B274-22 Wire, 1 Ft length (marked “-2882”)	1
5	KI-266A	Diode Assembly Includes: [A/R] B158-103 Heat Shrink [1] B260-2 Ring Terminal [1] B261-2 Splice [1] D275-102 Diode	1

Special Tools:

- Wire stripping and crimping tools.

Kit Instructions

1. Turn BATTERY switch OFF. Disconnect battery ground (NEG) cable at battery per R66 Maintenance Manual (MM) § 96-12 B. 1 thru 6.
2. Remove aft-left backrest assembly per MM § 25-22.

NOTE

Parenthetic dash numbers, such as (-2690), indicate number marked on wiring.

3. Refer to Figure 1. Remove and retain hardware securing ring terminals of (-65) & (-2882) wires to B415-2 relay forward terminal (marked “-”, “85”).
4. Cut (-65) & (-2882) wires as close as possible to crimped end of diode assemblies, retaining as much wire length as possible. Discard diode assemblies. Strip ends of (-65) & (-2882) wires.
5. Refer to Figure 2. Strip one end of KI-266-2882 wire. Crimp existing (-65) wire & KI-266-2882 wire to KI-266A diode assembly’s B261-2 splice. Verify security of crimp.

Kit Instructions (continued)

6. Using retained hardware, secure diode assembly's ring terminal to battery relay forward terminal (marked "-", "85") and special torque screw to 10 in.-lb. Verify diode security.
7. Route KI-266-2882 wire to existing (-2882) wire. Trim KI-266-2882 wire to length and strip trimmed end. Slide B158-6-SB-32 heat shrink onto (-2882) wire. Crimp (-2882) wires to each end of (supplied) B261-2 splice. Verify security of crimps. Slide B158-6-SB-32 heat shrink over splice so "SB-32" is visible and apply heat.
8. Secure wires using appropriately-sized ty-raps as necessary, ensuring wires are not stressed.

CAUTION

Stressed wires can affect conductivity and damage diode assembly.

9. Install aft left backrest assembly per MM § 25-22.
10. Verify BATTERY switch is OFF and battery (NEG) ground terminal is clean. Connect battery ground cable at battery per MM § 96-12 C. 7 & 8.
11. Install auxiliary fuel tank per MM § 28-51, if removed and required.
12. Make appropriate maintenance record entries. No change to Weight and Balance Record is required.

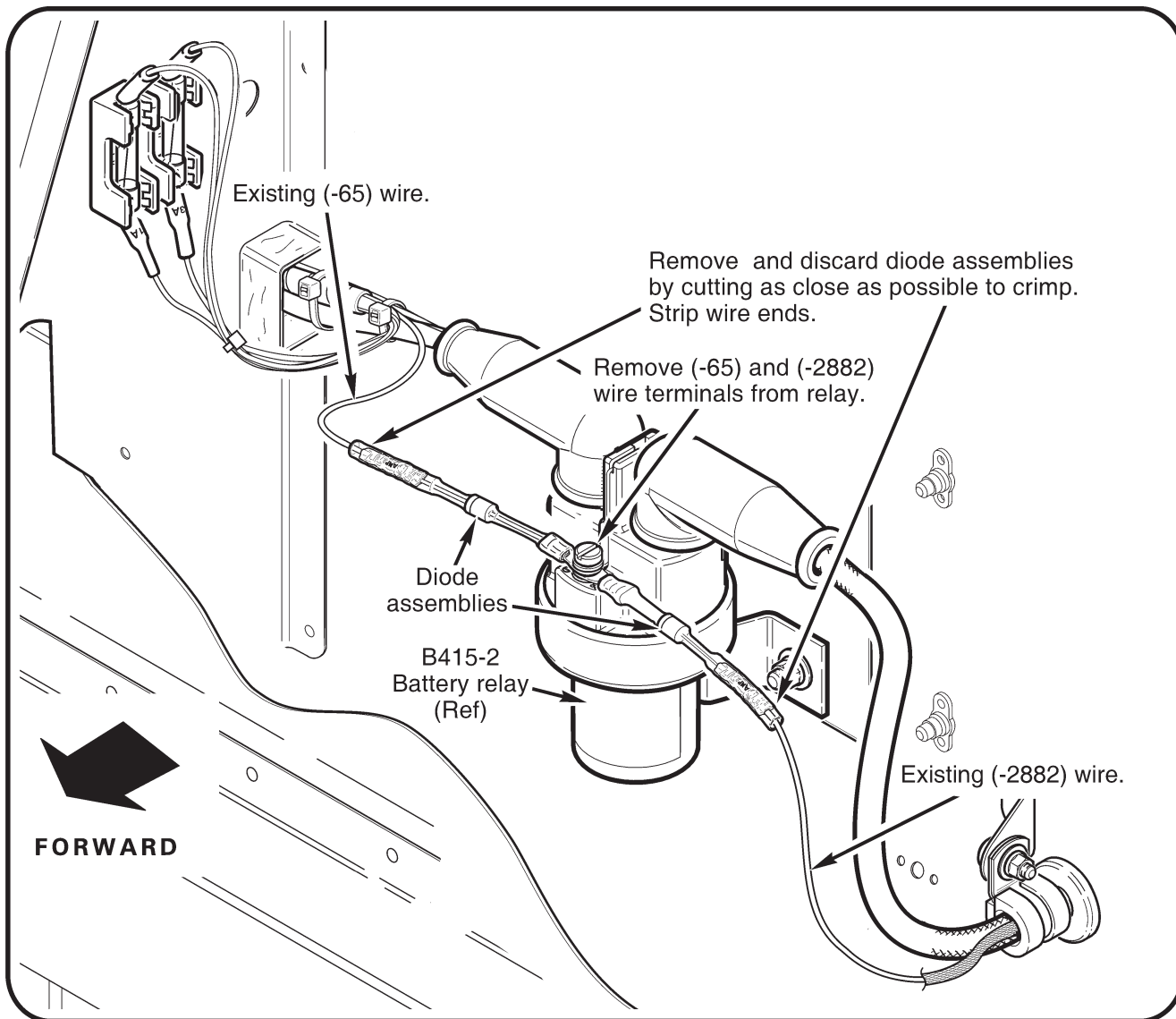

FIGURE 1 Existing installation
(view looking aft & inboard)

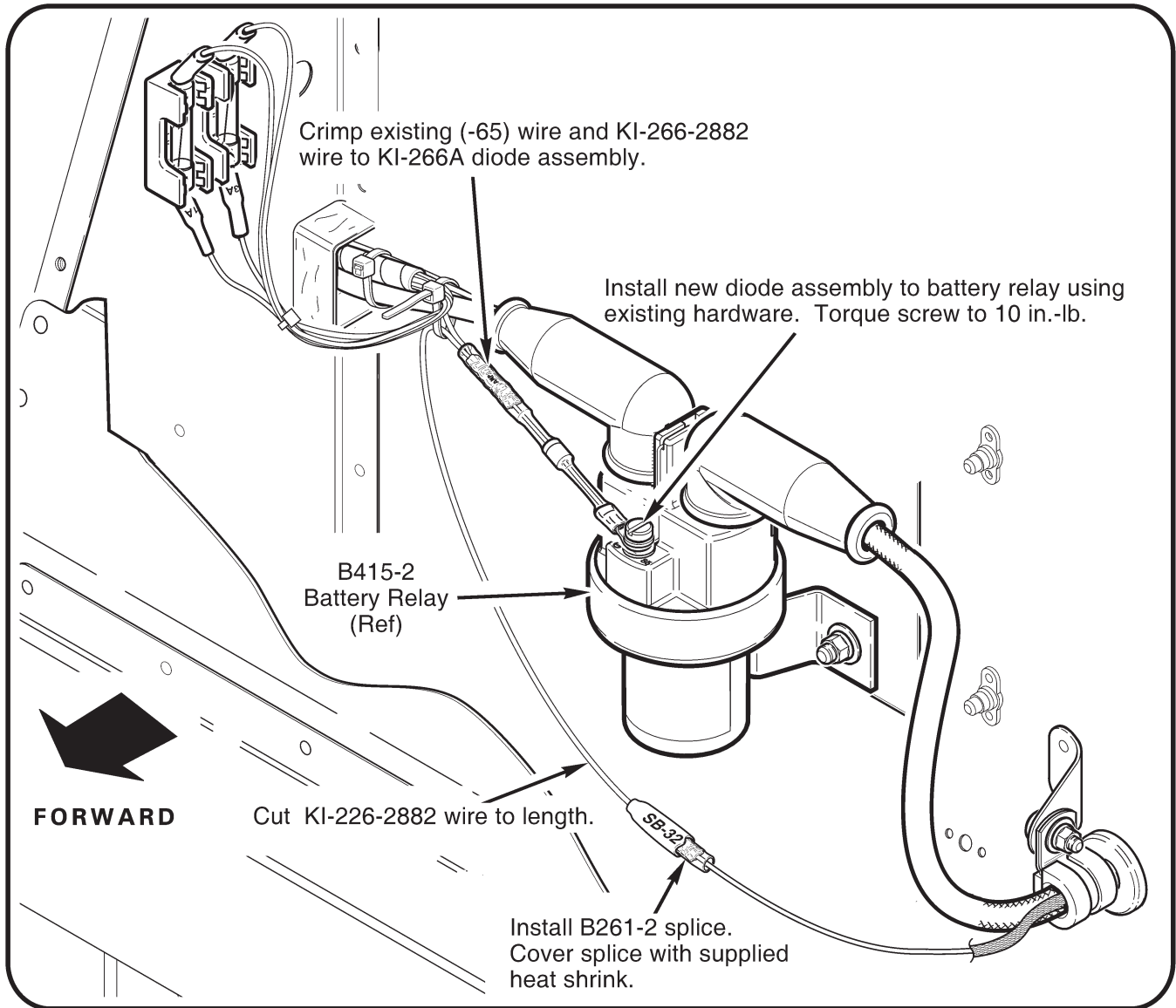

FIGURE 2 Installation of supplied diode assembly
(view looking aft & inboard)