

R22

Page 1 of 2

SERVICE BULLETIN SB-97

DATE: 22 February 2008

TO: R22 Owners, Operators, and Service Centers

SUBJECT: Pedal Support Safety Tabs

ROTORCRAFT AFFECTED: R22 Helicopters S/N 0002 thru 3325 with more than 2200 hours total time in service.

TIME OF COMPLIANCE: Within next 100 flight hours or by 31 May 2008, whichever occurs first.

BACKGROUND: RHC has received reports of early-revision 0.040-inch thick A359-1 & -2 pedal bearing block supports cracking on aircraft with more than 7000 hours time in service. Later-revision supports are thicker. If helicopter has more than 2200 hours time in service and 0.040-inch thick supports are installed, this Service Bulletin requires installing safety tabs to prevent possible tail rotor control binding if a support fails.

COMPLIANCE PROCEDURE:

1. Refer to figure on page 2. Open instrument console to access left A359-1 and right A359-2 supports. Visually inspect both supports and verify no cracks. Pay particular attention to area near NAS6603-13 bolts. Replace any cracked support before further flight.
2. Measure thickness of both supports. If either support is 0.040-inch thick, proceed to step 3. If both supports are at least 0.050-inch thick, no further action is required. Close and secure instrument console.
3. For each affected helicopter, order two B831-1 safety tabs from RHC Customer Service. (Two tabs are included with each Service Bulletin mailed to owners in the United States).
4. Dampen carpet adhesive between left-seat and right-seat pedals with Dupont Prep-Sol (or equivalent) to facilitate removal. Gently peel back carpeting and remove covers between pedals. Remove aft-vertical NAS6603-20 bolt and corresponding hardware from left and right bearing blocks and discard one accompanying washer per side.
5. Install a B831-1 tab under head of both NAS6603-20 bolts per figure on page 2. Torque both bolts at head to 55 in.-lb and torque stripe.

(OVER)

6. Reinstall covers between pedals and secure carpet with B270-7 contact adhesive (3M #74, or equivalent).
7. Make appropriate maintenance record entries.
8. At next 2200-hour overhaul, replace 0.040-inch thick A359-1 and/or -2 supports with thicker version.

Approximate Cost:

Parts: No charge for B831-1 tabs if ordered by 31 May 2008. Order must include helicopter serial number.

Labor: 1.0 hour.

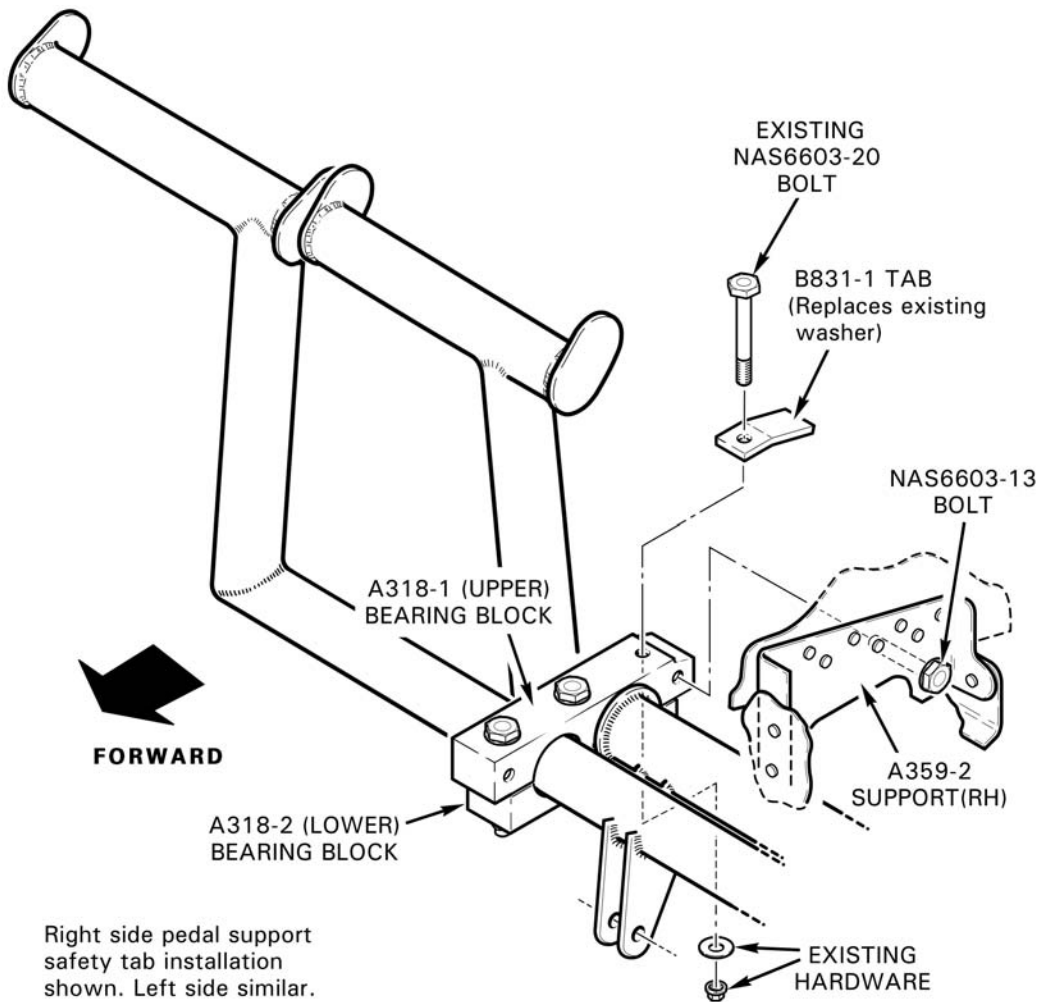

THE DESIGN ENGINEERING ASPECTS OF THIS BULLETIN HAVE BEEN SHOWN TO COMPLY WITH APPLICABLE FEDERAL AVIATION REGULATIONS AND ARE FAA APPROVED.