

SERVICE BULLETIN #40

Date: 20 June 1984

To: All R22 Alpha Owners and Operators

Subject: Modification of forward right-hand landing gear mount shackle.

Rotorcraft Affected: R22 Alpha Helicopter Serial No. 0301, and 0350 through 0374.

Time of Compliance: Within the next 50 flight hours or by 1 September 1984, whichever comes first.

Background: The A014-5 shackle assy was found to have insufficient clearance with the landing gear strut elbow. The A014-5 shackle assy must be modified per the following instructions.

---

A. SHACKLE REMOVAL

1. Remove forward cross tube cover panel.
2. Hoist aircraft 2-3 inches off floor (per section 1.210 of the Maintenance Manual).
3. Disconnect both forward landing gear attach bolts and slowly lower the forward end of the skid tubes to the floor.

CAUTION

The forward end of skid tubes must rest on the floor or be supported to prevent bending of the aft landing gear attach bolts or supports.

4. Disconnect A014-5 shackle from cabin. Keep washers and spacers in proper order for reinstallation.
5. Remove journal and teflon liners from inside shackle assembly.

B. SHACKLE MODIFICATION

1. Using a half round file, carefully file the shackle in the area indicated in Figure 2. The dished out area should be .80" long, .60" wide and .10" deep (at center).

2. Polish filed area with 400 grit sand paper, prime with zinc cromate primer and paint black.

C. SHACKLE INSTALLATION

1. Install teflon liners and journal in A014-5 shackle assembly.
2. Install shackle assembly to forward right hand cabin mount. Reinstall spacers and washers per Figure 2 with teflon washers on each end of shackle.
3. Torque nut on NAS1306-48 shackle attach bolt to 300 in./lbs, plus nut drag. Install palnut and torque stripe,
4. Re-connect landing gear to forward cabin mounts per Figure 1. Insure large area washers are installed on both sides of landing gear strut elbows.

NOTE

All mounting bolts are installed from the aft side.

5. Torque nut on NAS1304-41 landing gear attach bolts to 300 in./lbs. plus nut drag. Install palnut and torque stripe.

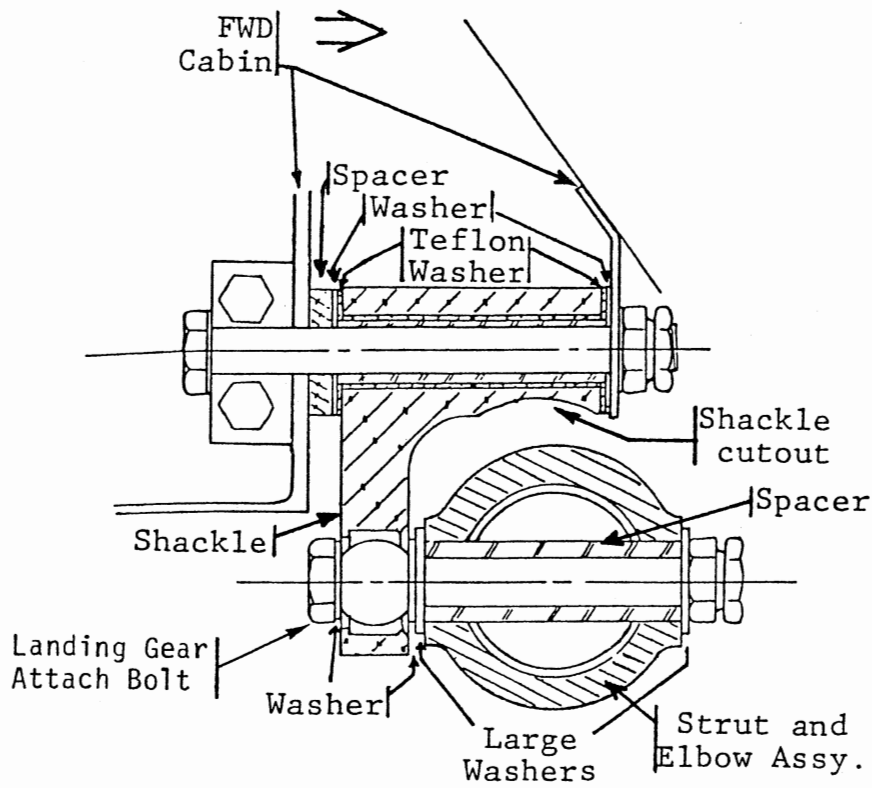

Figure 1 Shackle Assy (RT Front)

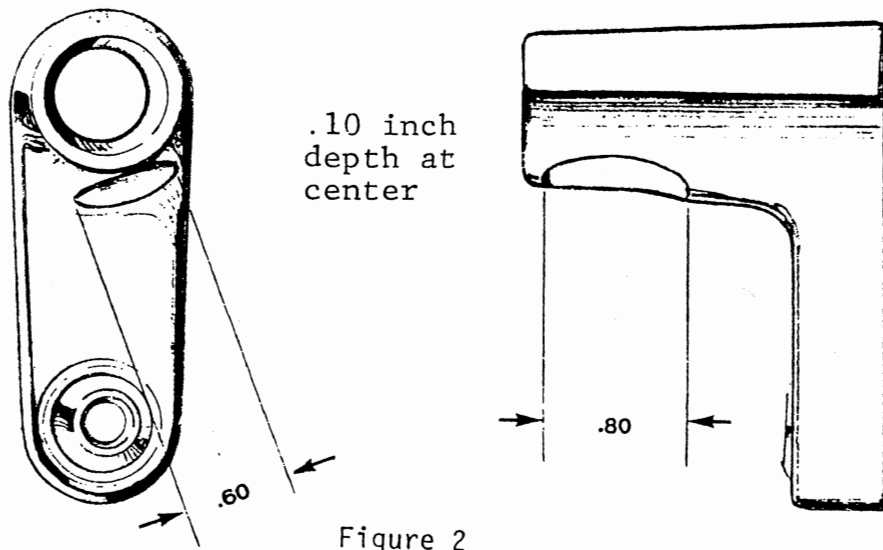

Figure 2