

M A N D A T O R Y  
SERVICE BULLETIN #24

Date: October 23, 1982

To: All owners and operators of Robinson R22 Helicopters

Subject: Low RPM Warning Light Installation

Rotorcraft Affected: Robinson Helicopters Serial No. 0002 thru 0250

Time of Compliance: ~~During the next 25 flight hours~~

**IMMEDIATE ACTION REQUIRED**

Background: Fatal accidents have occurred because the pilot failed to take immediate corrective action when his RPM became dangerously low. The low RPM warning horn alerts the pilot that something is wrong. The warning light will tend to draw his attention directly to the tachometer so he can identify the problem more quickly.

---

Low RPM Light Installation Instructions

1. Remove the five screws securing the instrument panel to the upper console.
2. Unsolder and tag the four wires to the main rotor chip and low fuel warning lights.
3. Remove the light sockets and align the two upper holes in the enclosed faceplate with the holes in the panel. Mark the lower hole on the instrument panel through the faceplate.
4. Remove the faceplate and drill a 15/32 (.469) inch dia. hole at the location marked on the instrument panel. Deburr the hole.
5. Install the faceplate, low RPM, main rotor chip and low fuel warning lights at the locations indicated.
6. Slip a piece of heat shrink over each of the tagged wires and re-connect them as tagged to the main rotor chip and low fuel warning lights.
7. Connect terminal on wire #175 from the low RPM light to the ground terminal in the upper console.
8. Remove the clamp holding the low RPM horn relay and remove the heat shrink.

-Continued-

SERVICE BULLETIN #24

9. Cut to length and solder the #174 wire from the low RPM light to the relay terminal with wire #78 attached. Slide a new piece of heat shrink over the relay and shrink with a heat gun.
10. Reinstall the relay and clamp, instrument panel and close the upper console.
11. To test:  
Turn on the battery switch and lift the collective.  
The low RPM warning light should illuminate when the horn sounds.

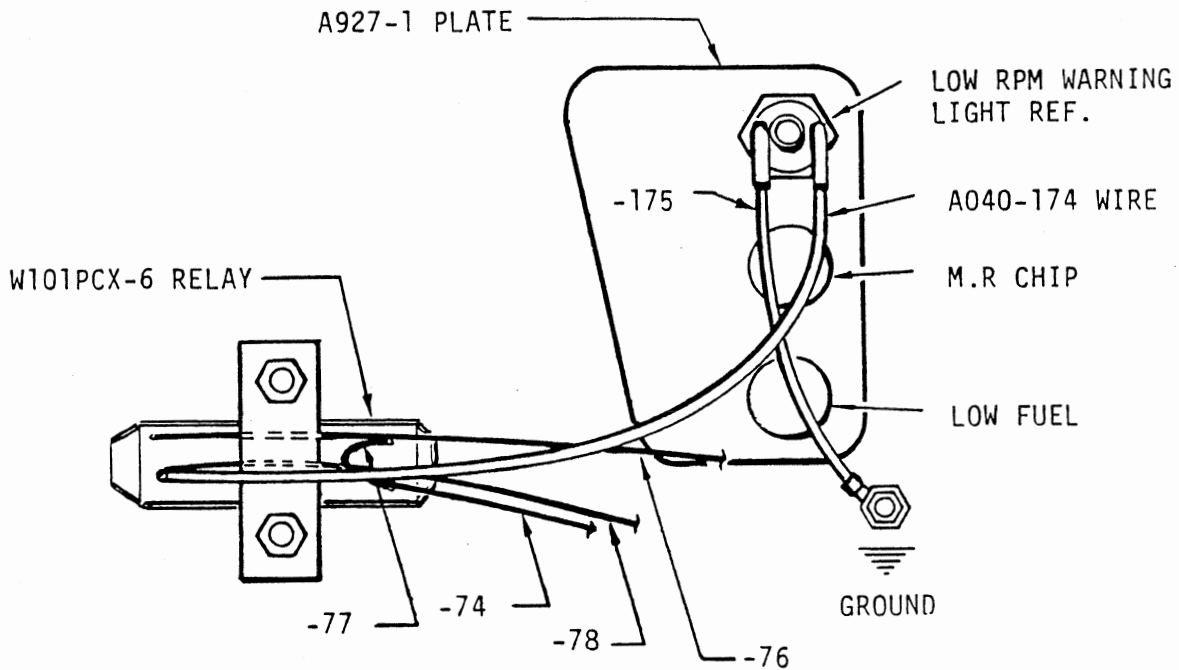

FIGURE 1

KIT CONTAINS:	A927-1 PLATE	1
	162-8430-0933-502 LIGHT, YELLOW	1
	#330 BLUB	1